

双卡套接头产品目录

Tube Fittings Product Catalog

依乔流体技术(上海)有限公司

www.e-joe.cn

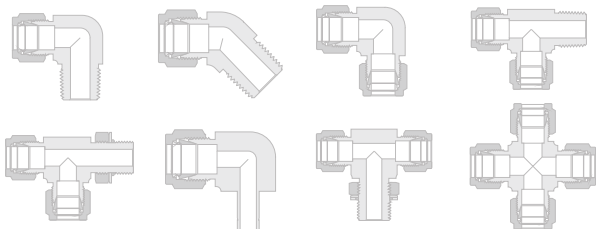
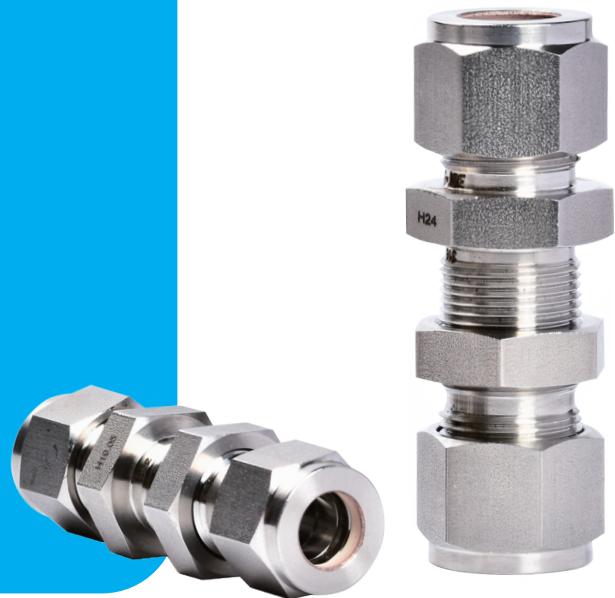

CONTENTS

04	卡套阳螺纹接头	
26	卡套阳螺纹穿板接头	
27	卡套阳螺纹镗通接头	
28	色谱分析接头	
29	卡套阴螺纹接头	
34	卡套阴螺纹穿板接头	
35	卡套直通接头	
36	卡套直通转换接头	
37	卡套直通变径接头	
38	柱端接头	
39	卡套直通穿板接头	
40	卡套直通穿板变径接头	
40	卡套直通穿板转换接头	
41	卡套直通穿舱接头	

41 穿板锁紧螺母



59 主管阴螺纹卡套三通

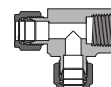

42 卡套阳螺纹弯头



60 卡套三通

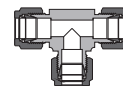

45 45° 卡套阳螺纹弯头

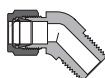

61 卡套变径三通

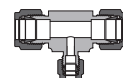

46 卡套阳螺纹位置可调弯头



63 卡套四通

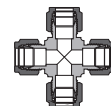

48 45° 卡套阳螺纹位置可调弯头

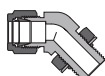

63 卡套管帽



49 卡套阴螺纹弯头

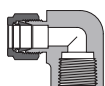

64 卡套堵头



50 卡套弯头



64 排放保护器



51 卡套变径弯头



64 卡套松套法兰接头

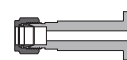

52 卡套双穿板弯头

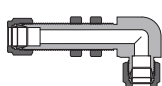

65 卡套螺母



53 支管阳螺纹卡套三通

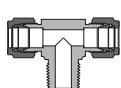

65 卡套滚花螺母



54 主管阳螺纹卡套三通

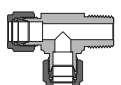

65 卡套阳螺纹螺母



55 支管阳螺纹位置可调卡套三通

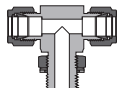

66 前卡套



57 主管阳螺纹位置可调卡套三通

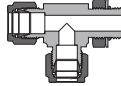

66 后卡套



58 支管阴螺纹卡套三通



67 螺母-卡套组件



67 卡套组件



68 卡套-卡套管



70 卡套穿板-卡套管



70 卡套-卡套管弯头



71 主管支管卡套管三通

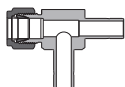

71 支管卡套管三通

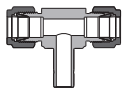

71 主管卡套管三通

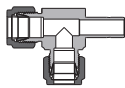

71 主管双卡套管三通

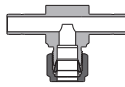

72 软管插头



72 端口接头



73 变径端口接头



73 卫生法兰接头

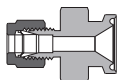

74 卡套管-阳螺纹



79 卡套管-阴螺纹



82 卡套管-焊接



83 卡套-法兰

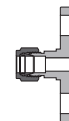

85 卡套焊接接头



86 卡套焊接弯头

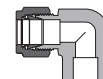

87 卡套校验接头



88 卡套绝缘接头

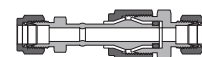

89 BS、BSD 垫片 - BS、BSD



89 BR 垫片 - BR



90 FG、RJ 垫片 - FG、RJ



91 O 形圈 - VI、BN



产品特征

- ◆ 尺寸从1/16"至1 1/2"和2mm至38mm
- ◆ 多种材质可选, 不锈钢、高镍不锈钢、黄铜、哈氏合金、因科耐尔合金、钛合金、蒙乃尔合金等
- ◆ 零部件加工精度高, 确保卡套和管子变形精准
- ◆ 双卡套接头提供全金属密封, 无弹性密封原件, 密封更可靠
- ◆ E-JOE特殊处理的后卡套, 保证了密封的安全可靠
- ◆ 螺母螺纹镀银处理, 有效减少与本体螺纹的摩擦系数, 避免螺纹咬合
- ◆ 接头拆卸和重新紧固方便

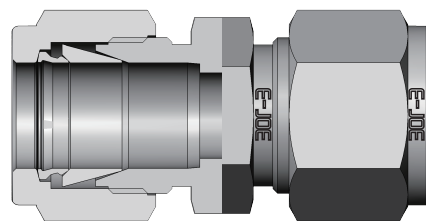

性能及测试

E-JOE双卡套接头符合ASTM F1387-1999(2012)标准的要求

- ◆ 气体静压测试(1.5倍工作压力的氮气): 无气泡
- ◆ 静水压力测试(1.5倍工作压力): 无泄漏
- ◆ 振动和脉冲测试(脉冲频率0.5Hz至1.7Hz, 振动频率23Hz至47Hz): 无泄漏
- ◆ 弯曲疲劳测试: 无泄漏
- ◆ 拉伸测试: 未发生连接分离水压爆破测试: 无泄漏
- ◆ 重复装配测试(10次): 均无泄漏旋转弯曲测试: 无泄漏
- ◆ 热循环测试: 无泄漏
- ◆ 应力腐蚀测试: 表面无裂纹、蚀斑、无泄漏、无晶间腐蚀倾向
- ◆ 扭力测试: 无泄漏
- ◆ 耐火测试: 无泄漏
- ◆ 真空测试: 泄露率小于 1×10^{-13} mbarl/s

技术数据

螺纹端

▶ NPT螺纹(NPT)

遵照标准ASME B1.20.1, SAE AS71051.

- 牙型角60°
- 以英寸为单位测量螺距
- 牙底和牙顶的截面是平的
- 锥度1:16
- 密封类型: 螺纹密封剂

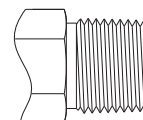

螺纹端参数						
螺纹尺寸	牙数/in.	参考平面上的直径(mm)			手紧旋合长度	
		大径	中径	小径	(mm)	牙数
1/16	27	7.894	7.142	6.389	4.064	4.32
1/8		10.242	9.489	8.737	4.102	4.36
1/4	18	13.616	12.487	11.358	5.785	4.10
3/8		17.055	15.926	14.797	6.096	4.32
1/2	14	21.224	19.772	18.321	8.128	4.48
3/4		26.569	25.117	23.666	8.618	4.75
1	11.5	33.228	31.461	29.694	10.160	4.60
1 1/4		41.985	40.218	38.451	10.668	4.83
1 1/2		48.054	46.287	44.520	10.668	4.83
2		60.092	58.325	56.558	11.065	5.01

NPT 螺纹端工作压力

螺纹尺寸	316 不锈钢和碳钢				黄铜				合金 400				钛			
	阳螺纹		阴螺纹		阳螺纹		阴螺纹		阳螺纹		阴螺纹		阳螺纹		阴螺纹	
	psig	bar	psig	bar	psig	bar	psig	bar	psig	bar	psig	bar	psig	bar	psig	bar
1/16	11000	757	6700	460	5500	378	3300	227	9900	682	6000	413	8800	606	5300	365
1/8	10000	690	6500	447	5000	344	3200	220	9000	620	5800	399	8000	551	5200	358
1/4	8000	551	6600	454	4000	275	3300	227	7200	496	5900	406	6400	440	5200	358
3/8	7800	537	5300	365	3900	268	2600	179	7000	482	4700	323	6200	427	4200	289
1/2	7700	530	4900	337	3800	261	2400	165	6900	475	4400	303	6100	420	3900	268
3/4	7300	502	4600	316	3600	248	2300	158	6500	447	4100	282	5800	399	3600	248
1	5300	365	4400	303	2600	179	2200	151	4700	323	3900	268	4200	289	3500	241
1 1/4	6000	410	5000	344	3000	200	2500	172	5400	372	4500	372	4800	330	4000	275
1 1/2	5000	344	4600	317	2500	172	2300	158	4500	310	4100	282	4000	275	3600	248
2	3900	268	3900	268	1900	130	1900	130	3500	241	3500	241	3100	213	3100	213

工作压力是在环境温度下以 ANSI/ASME B31.3为基准。

NPT 螺纹端工作压力

螺纹尺寸	合金 2507和合金 625				6-钼				合金 825			
	阳螺纹		阴螺纹		阳螺纹		阴螺纹		阳螺纹		阴螺纹	
	psig	bar	psig	bar	psig	bar	psig	bar	psig	bar	psig	bar
1/16	15000	1033	12900	888	14900	1026	9000	620	12800	881	7800	537
1/8	15000	1033	12500	861	13500	930	8800	606	11600	799	7500	516
1/4	15000	1033	12700	875	10800	744	8900	613	9300	640	7600	523
3/8	15000	1033	10200	702	10500	723	7100	489	9000	620	6100	420
1/2	14800	1019	9400	647	10400	716	6600	454	8900	613	5700	392
3/4	10000	689	8900	613	9800	675	6200	427	8500	585	5300	365
1	10000	689	8500	585	7100	489	5900	406	6100	420	5100	351
1 1/4	10000	689	9600	661	8100	558	6700	461	6900	475	5800	399
1 1/2	9600	661	8900	613	6700	461	6200	427	5800	399	5300	365
2	7500	516	7500	516	5200	358	5200	358	4500	310	4500	310

工作压力是在环境温度下以 ANSI/ASME B31.3为基准。

► ISO 锥螺纹(R,R1, R2, RC, RT, PT, BSPT, ZG)

遵照标准 ISO 7-1,EN 10226-1,BS 21,DIN 2999,JIS BO203

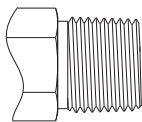

- 牙型角 55°
- 以英寸为单位测量螺距
- 牙底和牙顶的截面是圆弧的
- 锥度1:16
- 密封类型: 螺纹密封剂

螺纹数据					
螺纹尺寸	牙数/in.	参考平面上的直径(mm)			基准距离
		大径	中径	小径	
1/16	28	7.894	7.142	6.389	4.0
1/8		10.242	9.489	8.737	4.0
1/4	19	13.616	12.487	11.358	6.0
3/8		17.055	15.926	14.797	6.4
1/2	14	21.224	19.772	18.321	8.2
3/4		26.569	25.117	23.666	9.5
1	11	33.228	31.461	29.694	10.4
1 1/4		41.985	40.218	38.451	12.7
1 1/2		48.054	46.287	44.520	12.7
2		60.092	58.325	56.558	15.9

ISO 锥螺纹端工作压力 ISO 锥螺纹端的工作压力等同于 NPT 螺纹端。

► ISO 平行螺纹 (G RP PF BSPP)

遵照标准 ISO 228-1,DIN ISO 228-1,JIS B0203,BS 2779

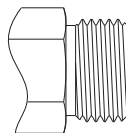

- 牙型角 55°
- 以英寸为单位测量螺距
- 牙底和牙顶的截面是圆弧的

螺纹数据				
螺纹尺寸	牙数/in.	参考平面上的直径(mm)		
		大径	中径	小径
1/16	28	7.723	7.142	6.561
1/8		9.728	9.147	8.566
1/4	19	13.157	12.301	11.445
3/8		16.662	15.806	14.950
1/2	14	20.955	19.793	18.631
5/8		22.911	21.749	20.587
3/4		26.441	25.279	24.117
7/8		30.201	29.039	27.877
1	11	33.249	31.770	30.291
1 1/8		37.897	36.418	34.939
1 1/4		41.910	40.431	38.952
1 1/2		47.803	46.324	44.845
1 3/4		53.746	52.267	50.788
2		59.614	58.135	56.656

► ISO 平行螺纹密封类型

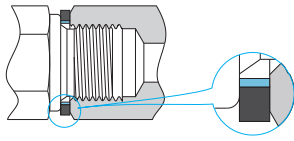

BS 阳螺纹端, BS 垫片和 BR 端口

- ◆ BS 阳螺纹端遵照标准 DIN 3852-2 A型
- ◆ BS 垫片
- ◆ BR 端口遵照标准 DIN 3852-2 X型

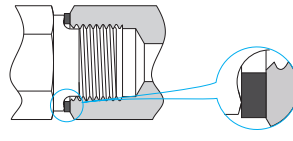

BR 阳螺纹端, BR 垫片和 BR 端口

- ◆ BR 阳螺纹端遵照标准 DIN 3852-2 B型
- ◆ BR 垫片
- ◆ BR 端口遵照标准 DIN 3852-2 X型

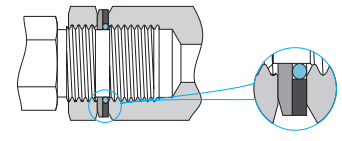

PP 阳螺纹端和 BR 端口

- ◆ BR 端口遵照标准 DIN 3852-2 X型

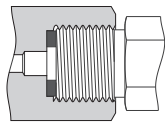

FG 端口, FG 垫片和 BP 阳螺纹端

- ◆ FG 端口遵照标准 EN 837-1/3
- ◆ FG 垫片

位置可调 ISO 平行螺纹端(PP)工作压力

螺纹尺寸	316不锈钢和碳钢	
	psig	bar
1/8 1/4 3/8	4568	315
1/2 3/4 1	2320	160

► SAE/MS 直螺纹(UN,UNJ)

遵照标准 ASME B1.1,SAE J475, ISO R725

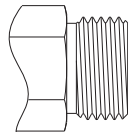

- 牙型角 60°
- 以英寸为单位测量螺距
- 牙底和牙顶的截面是平的

螺纹数据				
螺纹尺寸	牙数/in.	参考平面上的直径(mm)		
		大径	中径	小径
5/16-24	28	7.723	7.142	6.561
3/8-24		9.728	9.147	8.566
7/16-20	19	13.157	12.301	11.445
1/2-20		16.662	15.806	14.950
9/16-18	14	20.955	19.793	18.631
3/4-16		22.911	21.749	20.587
7/8-14		26.441	25.279	24.117
11/16-12		30.201	29.039	27.877
13/16-12	11	33.249	31.770	30.291
15/16-12		37.897	36.418	34.939
15/8-12		41.910	40.431	38.952
17/8-12		47.803	46.324	44.845
21/2-12		53.746	52.267	50.788
		59.614	58.135	56.656

► SAE/MS 螺纹密封类型

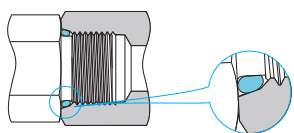

ST/SH 阳螺纹端和 SAE J1926-1 端口

- ◆ ST 阳螺纹端 (轻型) 遵照标准 SAE J1926-3
- ◆ SH 阳螺纹端 (重型) 遵照标准 SAE J1926-2
- ◆ O形圈, 见91页

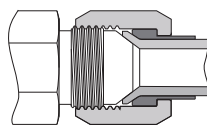

37° 阳螺纹端(AN)和扩口管

- ◆ 密封类型遵照标准 SAE J514
- ◆ 压力参照《37° 扩口接头》样本

SAE/MS 螺纹端工作压力

SAE 名义尺寸	螺纹尺寸	316 不锈钢和碳钢							
		轻型				重型			
		位置不可调		位置可调		位置不可调		位置可调	
		psig	bar	psig	bar	psig	bar	psig	bar
2	5/16-24	5075	350	5075	350	/	/	/	/
3	3/8-24					9135	630	6090	420
4	7/16-20			4568	315	9135	630	6090	420
5	1/2-20			4060	280	9135	630	6090	420
6	9/16-18					9135	630	6090	420
8	3/4-16	4568	315	9135	630	6090	420		
10	7/8-14	3626	250	3045	210	9135	630	6090	420
12	11/16-12					6090	420	6090	420
14	13/16-12	3045	210	2538	175	6090	420	6090	420
16	15/16-12					6090	420	5075	350
20	15/8-12	2538	175	2030	140	4060	280	4060	280
24	1 7/8-12					4060	280	3045	210
32	2 1/2-12	2030	140	1523	105	3045	210	2537	175

工作压力是在环境温度下以 SAE J1926-3 (轻型) 和 SAE J1926-2 (重型) 为基础

► 公制螺纹

遵照标准 ISO 261

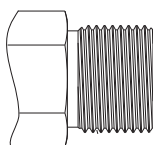

- 牙型角 60°
- 以毫米为单位测量螺距
- 牙底和牙顶的截面是平的

螺纹参数				
螺纹尺寸	螺距(mm)	基本直径 (mm)		
		大径	中径	小径
M6 x 1	1	6.000	5.350	4.917
M8 x 1		8.000	7.350	6.917
M10 x 1		10.000	9.350	8.917
M12 x 1.5	1.5	12.000	11.026	10.376
M14 x 1.5		14.000	13.026	12.376
M16 x 1.5		16.000	15.026	14.376
M18 x 1.5		18.000	17.026	16.376
M20 x 1.5		20.000	19.026	18.376
M22 x 1.5		22.000	21.026	20.376
M24 x 1.5		24.000	23.026	22.376
M27 x 2	2	27.000	25.701	24.835
M30 x 2		30.000	28.701	27.835
M33 x 2		33.000	31.701	30.835
M36 x 2		36.000	34.701	33.835
M39 x 2		39.000	37.701	36.835
M42 x 2		42.000	40.701	39.835
M45 x 2		45.000	43.701	42.835
M48 x 2		48.000	46.701	45.835

▶ 公制螺纹密封类型

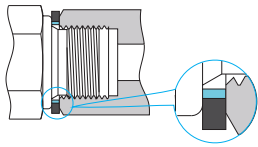

MRS 阳螺纹端, BS-M 垫片和 MS 端口

- ◆ MRS 阳螺纹端遵照标准 DIN3852-1 A型
- ◆ BS-M 垫片, 见89页

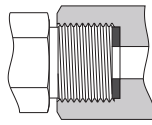

MS 阳螺纹端 FG-M 垫片 MS 端口

- ◆ FG-M垫片, 见90页

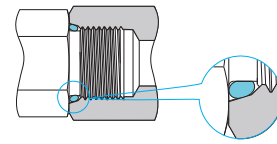

MST 阳螺纹端和 ISO 6149-1 端口

- ◆ MST阳螺纹端遵照标准 IOS 6149-3
- ◆ O形圈, 见91页

公制螺纹端工作压力

螺纹尺寸	不锈钢和碳钢			
	位置不可调		位置可调	
	psig	bar	psig	bar
M8 x 1	5800	400	4568	315
M10 x 1				
M12 x 1.5				
M14 x 1.5				
M16 x 1.5	4568	315	3626	250
M18 x 1.5				
M22 x 1.5				
M27 x 2				
M30 x 2	2900	200	2320	160
M33 x 2				
M42 x 2				
M48 x 2				
M60 x 2	2320	160	1450	100

工作压力是在环境温度下以ISO 6149-3 为基础。

▶▶ 对焊端

对焊端管尺寸及壁厚

Pipe 管尺寸		外径		公称壁厚SCH80	
NPS	DN	in.	mm	in.	mm
1/8	6	0.405	10.3	0.095	2.41
1/4	8	0.540	13.7	0.119	3.02
3/8	10	0.675	17.1	0.126	3.20
1/2	15	0.840	21.3	0.147	3.73
3/4	20	1.050	26.7	0.154	3.91
1	25	1.315	33.4	0.179	4.55
1 1/4	32	1.660	42.2	0.191	4.85
1 1/2	40	1.900	48.3	0.200	5.08

工作温度

螺纹端

- 螺纹端工作温度可能受限于特氟龙密封带或螺纹密封剂或垫片或 O 形圈。
- 当使用垫片或 O 形圈时, 工作温度见下表:

密封元件	材料	最小温度	最大温度
BS 垫片	丁腈橡胶	-13°F (-25°C)	230°F (110°C)
	碳氟化合物 FKM	5°F (-15°C)	400°F (204°C)
BR/FG 垫片	铜	-325°F (-198°C)	400°F (204°C)
	不锈钢	-425°F (-254°C)	1000°F (538°C)
FG 垫片	PTFE	-65°F (-54°C)	450°F (232°C)
	硬化纸板	-76°F (-60°C)	221°F (105°C)
O 形圈	丁腈橡胶	-22°F (-30°C)	230°F (110°C)
	碳氟化合物 FKM	-4°F (-20°C)	400°F (204°C)

- ◆ 环境温度下, 卡套端工作压力决定于使用的 E-JOE Tube 管的工作压力, Tube 管的工作压力见《Tubing 管》。
- ◆ 环境温度下, 螺纹端工作压力见上述规定。
- ◆ 要得到更高温度的最大工作压力, 用环境温度下的最大工作压力乘以《Tubing 管》样本第 12 页中升温系数表中的系数。
- ◆ 接头的工作压力就是所有端口工作压力值中最小的值。

材料

材料	棒料	锻件	代码
316 不锈钢	ASTM A296, ASME SA479, ASTM A479, EN 1.4401	ASTM A182, ASME SA182, EN 1.4401	SS
316L 不锈钢	ASTM A296, ASME SA479, ASTM A479, EN 1.4404	ASTM A182, ASME SA182, EN 1.4404	6L
304 不锈钢	ASTM A296, ASME SA479, ASTM A479, EN 1.4301	ASTM A182, ASME SA182, EN 1.4301	S4
321 不锈钢	ASTM A296, ASME SA479, ASTM A479, EN 1.4541	ASTM A182, ASME SA182, EN 1.4541	S1
316Ti 不锈钢	ASTM A296, ASME SA479, ASTM A479, EN 1.4571	ASTM A182, ASME SA182, EN 1.4571	6T
6Mo (S31254) 不锈钢	ASTM A479	ASTM A182	S12
904L 不锈钢	ASTM A479	ASTM A182	904L
钛 (等级 4)	ASTM B348	ASTM B381	TI
双相钢 2205	ASTM A479	ASTM A182	D5
超级双相钢 2507	ASTM A479	ASTM A182	D7
合金 20	ASTM A479	ASTM B462	A20
合金 400	ASTM B164, ASME SB164	ASTM B564, ASME SB564	M
合金 600	ASTM B166, ASME SB166	ASTM B564, ASME SB564	INC
合金 625	ASTM B446	ASTM B564, ASME SB564	A65
合金 718	ASTM B637	ASTM B637	A78
合金 825	ASTM B425	ASTM B564	A85
合金 C-276	ASTM B574	ASTM B564	HC
碳钢	ASTM A108	ASTM A105	CS
黄铜	ASTM B16/B453	ASTM B283	B
尼龙	ASTM D4066	/	PA
PTFE	ASTM D1710	/	T

注: 常规材料以加粗字体表示, 可快速供货; 其他材料按订单生产, 供货周期请联系 E-JOE 依乔流体。

▶▶ 压力等级基准和螺纹规格

螺纹类型 (端接)	压力等级基准	螺纹类型	参考规范
卡套管接头	卡套管接头端的额定值符合Tubing 管中列出的卡套管工作压力。	统一英制螺纹	ASME B1.1
NPT	ASME B31.3 工艺管道或压力测试, 设计系数为 4:1 (基于液液液泄漏)。	NPT	ASME B1.20.1 SAE AS71051
ISO/BSP (锥形)	ASME B31.3 工艺管道或压力测试, 设计系数为 4:1 (基于液液液泄漏)。	ISO/BSP (锥形)	ISO 7、BS EN 10226-1 JIS B0203
ISO/BSP (平行)	ISO 1179-3,ISO 228-1 螺纹, 带定位环 G 和 H 型 O 形圈密封的轻型 (L 系列) 螺柱端, 或压力测试, 设计系数为 4:1 (基于液液液泄漏)。	ISO/BSP (平行)	ISO 228 JIS B0202
ISO/BSP (平行)	ISO 1179-4,ISO 228-1 螺纹, 通用只带金属对金属密封件 (型) 的螺柱端头, 或压力测试, 设计系数为 4:1 (基于液液液泄漏)。	ISO/BSP (平行)	ISO 228 JIS B0202
ISO/BSP (压力表) (基于 EN 837-1 和 837-3)	ASME B31.3 工艺管道或压力测试, 设计系数为 4:1 (基于液液液泄漏)。	ISO/BSP (平行)	ISO 228 JIS B0202
SAE-轻型	SAE J1926/3,通用连接和流体动力端口以及带 ASME B1.1 螺纹和 O 形圈密封的螺柱端第 3 部分: 轻型 (L 系列) 螺柱端或压力测试, 设计系数为 4:1 (基于液液液泄漏)。	统一英制螺纹	ASME B1.1
SAE-重型	SAE J1926/2,一般用途和流体动力连接, 带 ASME B1.1 螺纹和 O 形圈密封的端口和螺柱端第 2 部分: 重型 (S 系列) 螺柱端或压力测试, 设计系数为 4:1 (基于液液液泄漏)。	统一英制螺纹	ASME B1.1
AN 接头	SAE J514, 液接管接头或压力测试, 设计系数为 4:1 (基于液液液泄漏)。	统一英制螺纹	ASME B1.1 UNJ SAE AS 8879

▶▶ 订购信息

注:型号说明用于说明 E-JOE 产品型号的组成规则, 不适用于产品的具体选型, 不能随意组合。
如有疑问, 请联系 E-JOE 依乔流体。

P1, P2, P3 和 P4 端口应该按照以下规则来描述:

- ◆ 卡套-Tube 管-NPT 螺纹-ISO 锥螺纹-ISO 平行螺纹-SAE/MS 直螺纹-37° 扩口 - Pipe 管对焊-英制 Tube 管插焊·其他
- ◆ 接头类型相同时, 按照接头尺寸从大到小的顺序描述。
- ◆ 如果所有接头的类型和尺寸都相同, 只需描述 P1 端口。

▶▶ 清洗和包装:

FC-01:一般工业用的标准清洗和包装。

FC-02:浸润系统组件的特殊清洗和包装, 应符合ASTM G93C清洁要求

▶▶ 特殊应用

硫钝化:主要湿润金属零部件做硫钝化处理。

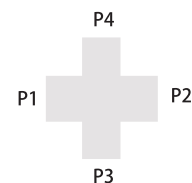

▶▶ 产品代码详情

◆ ASME B1.20.1



NPT 阴螺纹
代码: FN



NPT 阳螺纹
代码: N

◆ ISO 7-1



BSPT 阴螺纹
代码: FRT



BSPT 阳螺纹
代码: RT

◆ UN,UNJ



SAE 统一螺纹阴螺纹 (O 形圆密封)
代码: FST



SAE 统一螺纹阳螺纹 (O 形圆密封)
代码: ST



SAE 37度 阳螺纹 (37°)
代码: AN

◆ ISO 228-1



BSPP 阴螺纹 (BS 和 BR 垫片密封)
代码: FP



BSPP 阴螺纹 (FG 垫片密封)
代码: FG



BSPP 阳螺纹 (BS 垫片密封)
代码: BS



BSPP 阳螺纹 (BR 垫片密封)
代码: BR



BSPP 阳螺纹 (FG 垫片密封)
代码: BP

◆ Metric Thread



ISO 公制阴螺纹 (公制 BS 垫片/O 形圆密封)
代码: MP



ISO 公制阴螺纹 (FG 垫片 PTFE 或 紫铜)
代码: FM



ISO 公制阳螺纹 (BR 公制垫片)
代码: MR



ISO 公制阳螺纹 (FG 公制垫片 PTFE 或 紫铜)
代码: MS



ISO 公制阳螺纹 (O形圆密封)
代码: MO

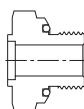

◆ SAE 统一螺纹阳螺纹 (O 圈密封)
代码: NO ASME B1.20.1
◆ NPT 阳螺纹 (O 圈密封)
代码: STO UN,UNJ

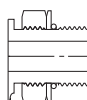

◆ BSPP 阳螺纹穿板活接
代码: SBP ISO 228-1
◆ SAE 统一阳螺纹穿板活接
代码: SOT UN,UNJ

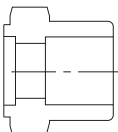

◆ 英制Pipe管插焊
代码: PS
◆ 英制Tube管插焊
代码: TS
◆ 公制Tube管插焊
代码: MTS

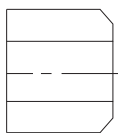

◆ 英制T管对焊
代码: TB
◆ 公制T管对焊
代码: MTB
◆ 英制P管对焊
代码: PB

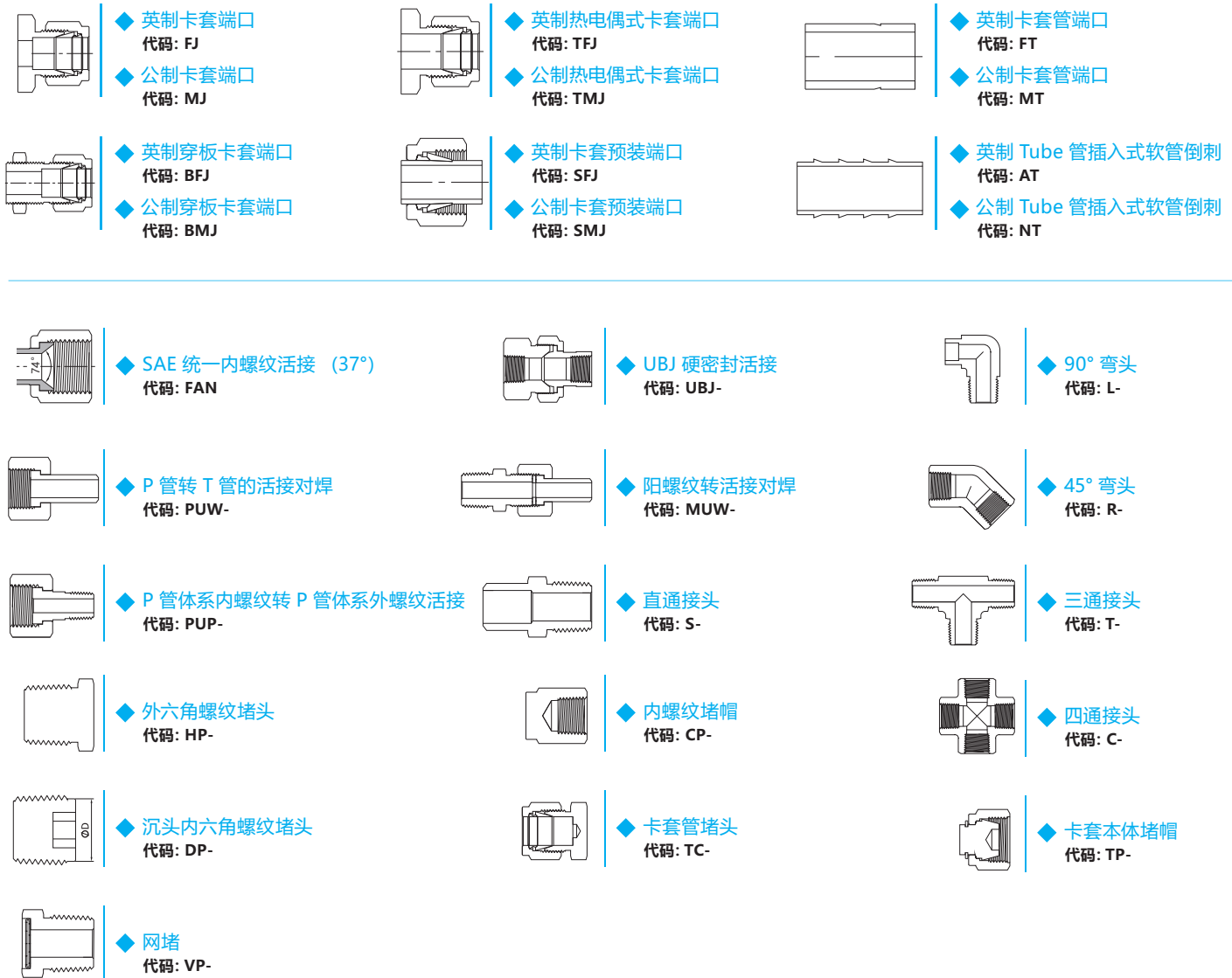

▶▶ 安装说明

▶▶ 手动安装

初始安装

1. 将螺母从手紧位置拧松1/4圈。
2. 将 Tube 管插入卡套接头内, 确保 Tube 管顶在端口的肩部。
3. 用手将螺母拧紧。
4. 将接头或阀门的本体牢牢固定, 用扳手拧螺母 1 1/4 圈 (图1)。对于小尺寸接头 (1/16"、1/8" 和 3/16"、2 mm、3 mm 和 4 mm), 用扳手拧螺母3/4圈 (图2)。

复装

1. 拆卸接头之前, 沿螺母背面在管子上作标记; 在螺母和接头本体的平面上画一条线。
2. 将卡套及管子总成插入本体, 直到前卡套顶在接头本体上。
3. 牢牢固定接头本体, 使用扳手将螺母旋转至管子和螺母及本体平面上的标志指示的先前紧固位置。
4. 轻轻拧紧螺母。

▶▶ 端口接头

Tube 管端的初始安装与复装与卡套接头相同, 非 Tube 管的初始安装与复装均与堵头相同。

▶ 使用手动预装器安装

初始安装

1. 牢牢固定住预装器；
2. 把螺母和卡套安装到预装器上；
3. 把管子插入预装器内，确保顶到预装器底部；
4. 然后用手拧紧螺母；
5. 用扳手顺时针拧紧螺母 1 1/4 圈（图1）；对于小尺寸接头（1/16"、1/8" 和 3/16"、2 mm、3 mm 和 4 mm），用扳手拧螺母3/4圈（图2）；
6. 拆卸接头前，沿螺母背面在管子上做标记；
7. 松开螺母，将预装好的卡套及管子总成插入接头本体内，直到前卡套顶到本体斜面上；
8. 牢牢固定接头本体，使用扳手将螺母旋转至管子上的标志指示的先前紧固位置；
9. 当感到安装阻力明显增大时，轻轻拧紧螺母。

复装

与“1”或 25mm 及以下的卡套接头”手动安装的复装方式相同。

▶▶ 使用液压预装器安装

仅适用于 1/2" ~ 1" 或 12mm ~ 25mm 之间的卡套接头

初始安装

1. 用预装器将卡套安装在 Tube 管上，具体细节见液压预装器的说明。
2. 将带有卡套和螺母的 Tube 管插入接头的本体内，用手将螺母拧紧。
3. 用扳手拧紧螺母 1/2 圈。

复装

与“1”或 25mm 及以下的卡套接头”手动安装的复装方式相同。



图 1

▶▶ 超过1" 或 25 mm 的卡套接头

初始安装

1. 用预装器将卡套安装在 Tube 管上，具体细节见 预装器的说明。
2. 将带有卡套和螺母的 Tube 管插入接头的本体内，用手将螺母拧紧。
3. 用扳手拧紧螺母 1/2 圈。

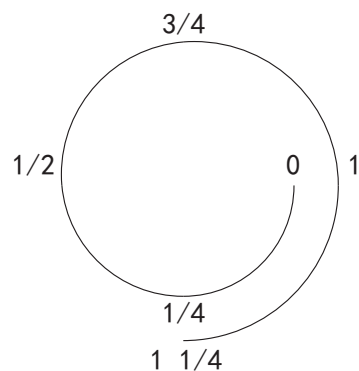
复装

与“1”或 25mm 及以下的卡套接头”手动安装的复装方式相同。

▶▶ 堵头

初始安装

1. 用预装器将卡套安装在 Tube 管上，具体细节见 预装器的说明。
2. 将带有卡套和螺母的 Tube 管插入接头的本体内，用手将螺母拧紧。
3. 用扳手拧紧螺母 1/2 圈。

复装

与“1”或 25mm 及以下的卡套接头”手动安装的复装方式相同。



图 2

▶▶▶ 警告

1. 不要在系统有压力的时候松开和紧固接头。
2. 确保 Tube 顶在端口的肩部。
3. 用于卡套接头的 Tube 管端应留有足够长的直端。
4. 对于非常软的塑料 Tube 管，要使用软管插头。
5. Tube 管的材质要始终比卡套接头软，例如，不锈钢 Tube 管不可使用黄铜卡套接头。当 Tube 管和卡套接头是相同的材质时，Tube 管必须经过完全退火。
6. 卡套接头的许用工作压力与管道系统中的 Tube 管的最大工作压力有关，具体参数可以查阅 E-JOE Tube 管数据表。当和卡套接头配合使用的 Tube 管在 E-JOE Tube 管数据表中没有时，请联系 E-JOE 依乔流体来获得其许用工作压力的相关信息。
7. 确保 Tube 管端面 and 表面清洁和光滑平整。
8. 在锥管螺纹上始终使用适当的螺纹密封剂，确保工作温度不超过密封剂的使用温度。
9. 安装卡套接头时，用扳手固定本体旋转螺母，而不是固定螺母旋转本体。
10. 当卡套端使用在阀门上，应固定阀体，旋转螺母。
11. 当卡套接头与阀门使用螺纹连接时，应固定阀体，旋转卡套接头本体。
12. 间隙检测规仅适用于手动初始安装后的检测。

尺寸说明

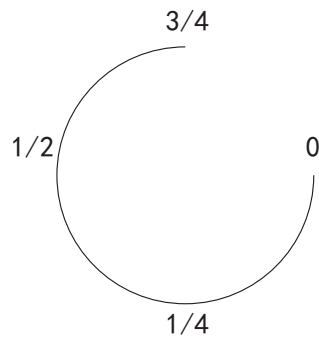
尺寸仅供参考, 可能会有变更; 所示尺寸为手紧时尺寸。

卡套阳螺纹接头

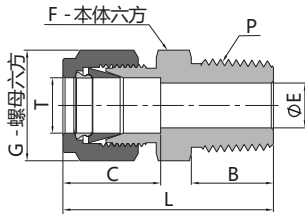

英制 Tube 管			NPT 螺纹					
T-Tube 管外径 (in.)	P-NPT 尺寸	基本 订购号	尺寸, in. (mm)					
			L	B	C	E*	G	F
1/16	1/16	-S-FJ1N1	0.94(23.9)	0.38(9.7)	0.34(8.6)	0.05(1.3)	0.31(7.9)	0.31(7.9)
1/16	1/8	-S-FJ1N2	1.03(26.2)	0.38(9.7)	0.34(8.6)	0.05(1.3)	0.31(7.9)	0.44(11.1)
1/16	1/4	-S-FJ1N4	1.22(31.0)	0.56(14.2)	0.34(8.6)	0.05(1.3)	0.31(7.9)	0.56(14.3)
1/8	1/16	-S-FJ2N1	1.17(29.7)	0.38(9.7)	0.50(12.7)	0.09(2.3)	0.44(11.1)	0.44(11.1)
1/8	1/8	-S-FJ2N2	1.20(30.5)	0.38(9.7)	0.50(12.7)	0.09(2.3)	0.44(11.1)	0.44(11.1)
1/8	1/4	-S-FJ2N4	1.40(35.6)	0.56(14.2)	0.50(12.7)	0.09(2.3)	0.44(11.1)	0.56(14.3)
1/8	3/8	-S-FJ2N6	1.41(35.8)	0.56(14.2)	0.50(12.7)	0.09(2.3)	0.44(11.1)	0.69(17.5)
1/8	1/2	-S-FJ3N8	1.66(42.2)	0.75(19.1)	0.50(12.7)	0.09(2.3)	0.44(11.1)	0.87(22.2)
3/16	1/16	-S-FJ3N1	1.23(31.2)	0.38(9.7)	0.54(13.7)	0.12(3.0)	0.50(12.7)	0.44(11.1)
3/16	1/8	-S-FJ3N2	1.23(31.2)	0.38(9.7)	0.54(13.7)	0.12(3.0)	0.50(12.7)	0.44(11.1)
3/16	1/4	-S-FJ4N4	1.43(36.3)	0.56(14.2)	0.54(13.7)	0.12(3.0)	0.50(12.7)	0.56(14.3)
1/4	1/16	-S-FJ4N1	1.29(32.8)	0.38(9.7)	0.60(15.2)	0.12(3.0)	0.56(14.3)	0.50(12.7)
1/4	1/8	-S-FJ4N2	1.29(32.8)	0.38(9.7)	0.60(15.2)	0.19(4.8)	0.56(14.3)	0.50(12.7)
1/4	1/4	-S-FJ4N4	1.49(37.8)	0.56(14.2)	0.60(15.2)	0.19(4.8)	0.56(14.3)	0.56(14.3)
1/4	3/8	-S-FJ4N6	1.51(38.4)	0.56(14.2)	0.60(15.2)	0.19(4.8)	0.56(14.3)	0.69(17.5)
1/4	1/2	-S-FJ4N8	1.76(44.7)	0.75(19.1)	0.60(15.2)	0.19(4.8)	0.56(14.3)	0.87(22.2)
1/4	3/4	-S-FJ4N12	1.82(46.2)	0.75(19.1)	0.60(15.2)	0.19(4.8)	0.56(14.3)	1.06(27.0)
5/16	1/8	-S-FJ5N2	1.34(34.0)	0.38(9.7)	0.64(16.3)	0.19(4.8)	0.63(15.9)	0.56(14.3)
5/16	1/4	-S-FJ5N4	1.52(38.6)	0.38(9.7)	0.64(16.3)	0.25(6.4)	0.63(15.9)	0.56(14.3)
5/16	3/8	-S-FJ5N6	1.54(39.1)	0.56(14.2)	0.64(16.3)	0.25(6.4)	0.63(15.9)	0.69(17.5)
5/16	1/2	-S-FJ5N8	1.79(45.5)	0.75(19.1)	0.64(16.3)	0.25(6.4)	0.63(15.9)	0.87(22.2)
3/8	1/8	-S-FJ6N2	1.39(35.3)	0.38(9.7)	0.66(16.8)	0.19(4.8)	0.69(17.5)	0.63(15.9)
3/8	1/4	-S-FJ6N4	1.57(39.9)	0.56(14.2)	0.66(16.8)	0.28(7.1)	0.69(17.5)	0.63(15.9)
3/8	3/8	-S-FJ6N6	1.57(39.9)	0.56(14.2)	0.66(16.8)	0.28(7.1)	0.69(17.5)	0.69(17.5)
3/8	1/2	-S-FJ6N8	1.82(46.2)	0.75(19.1)	0.66(16.8)	0.28(7.1)	0.69(17.5)	0.87(22.2)
3/8	3/4	-S-FJ6N12	1.88(47.8)	0.75(19.1)	0.66(16.8)	0.28(7.1)	0.69(17.5)	1.06(27.0)
3/8	1	-S-FJ6N16	2.14(54.4)	0.94(23.9)	0.66(16.8)	0.28(7.1)	0.69(17.5)	1.37(34.9)
1/2	1/8	-S-FJ8N2	1.53(38.9)	0.38(9.7)	0.90(22.9)	0.19(4.8)	0.87(22.2)	0.81(20.6)
1/2	1/4	-S-FJ8N4	1.71(43.4)	0.56(14.2)	0.90(22.9)	0.28(7.1)	0.87(22.2)	0.81(20.6)
1/2	3/8	-S-FJ8N6	1.71(43.4)	0.56(14.2)	0.90(22.9)	0.38(9.7)	0.87(22.2)	0.81(20.6)
1/2	1/2	-S-FJ8N8	1.93(49.0)	0.75(19.1)	0.90(22.9)	0.41(10.4)	0.87(22.2)	0.87(22.2)
1/2	3/4	-S-FJ8N12	1.99(50.5)	0.75(19.1)	0.90(22.9)	0.41(10.4)	0.87(22.2)	1.06(27.0)
1/2	1	-S-FJ8N16	2.25(57.2)	0.94(23.9)	0.90(22.9)	0.41(10.4)	0.87(22.2)	1.37(34.9)
5/8	1/4	-S-FJ10N4	1.74(44.2)	0.56(14.2)	0.96(24.4)	0.28(7.1)	1.00(25.4)	0.94(23.8)
5/8	3/8	-S-FJ10N6	1.74(44.2)	0.56(14.2)	0.96(24.4)	0.38(9.7)	1.00(25.4)	0.94(23.8)
5/8	1/2	-S-FJ10N8	1.93(49.0)	0.75(19.1)	0.96(24.4)	0.47(11.9)	1.00(25.4)	0.94(23.8)
5/8	3/4	-S-FJ10N12	1.99(50.5)	0.75(19.1)	0.96(24.4)	0.50(12.7)	1.00(25.4)	1.06(27.0)
3/4	3/8	-S-FJ12N6	1.80(45.7)	0.56(14.2)	0.96(24.4)	0.41(10.4)	1.13(28.6)	1.06(27.0)
3/4	1/2	-S-FJ12N8	1.99(50.5)	0.75(19.1)	0.96(24.4)	0.47(11.9)	1.13(28.6)	1.06(27.0)
3/4	3/4	-S-FJ12N12	1.99(50.5)	0.75(19.1)	0.96(24.4)	0.62(15.7)	1.13(28.6)	1.06(27.0)
3/4	1	-S-FJ12N16	2.25(57.2)	0.94(23.9)	0.96(24.4)	0.62(15.7)	1.13(28.6)	1.37(34.9)
7/8	1/2	-S-FJ14N8	1.99(50.5)	0.75(19.1)	1.02(25.9)	0.47(11.9)	1.25(31.8)	1.19(30.2)
7/8	3/4	-S-FJ14N12	1.99(50.5)	0.75(19.1)	1.02(25.9)	0.62(15.7)	1.25(31.8)	1.19(30.2)
7/8	1	-S-FJ14N16	2.25(57.2)	0.94(23.9)	1.02(25.9)	0.72(18.3)	1.25(31.8)	1.37(34.9)
1	1/2	-S-FJ16N8	2.26(57.4)	0.75(19.1)	1.23(31.2)	0.47(11.9)	1.50(38.1)	1.37(34.9)
1	3/4	-S-FJ16N12	2.26(57.4)	0.75(19.1)	1.23(31.2)	0.62(15.7)	1.50(38.1)	1.37(34.9)
1	1	-S-FJ16N16	2.45(62.2)	0.94(23.9)	1.23(31.2)	0.88(22.4)	1.50(38.1)	1.37(34.9)
1 1/8	1	-S-FJ18N16	2.45(62.2)	0.94(23.9)	1.44(36.7)	0.88(22.4)	1.75(44.5)	1.63(41.3)
1 1/4	1	-S-FJ20N16	3.04(77.2)	0.94(23.9)	1.62(41.1)	0.88(22.4)	1.87(47.6)	1.75(44.5)
1 1/4	1 1/4	-S-FJ20N20	3.04(77.2)	0.94(23.9)	1.62(41.1)	1.09(27.7)	1.87(47.6)	1.75(44.5)
1 1/2	1 1/2	-S-FJ24N24	3.50(88.9)	1.03(26.2)	1.97(50.0)	1.34(34.0)	2.25(57.2)	2.13(54.0)

◆ 尺寸“E”为最小公称孔口, 此孔口在管螺纹端、直螺纹端可能会更大。

▶ 卡套阳螺纹接头

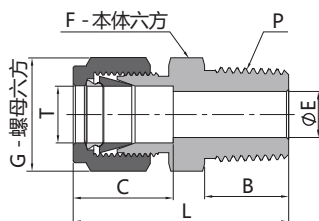

英制 Tube 管			ISO 锥螺纹 (RT)					
T-Tube 管外径 (in.)	P-RT 尺寸	基本 订购号	尺寸, in. (mm)					
			L	B	C	E*	G	F
1/8	1/8	-S-FJ2RT2	1.20(30.5)	0.38(9.7)	0.50(12.7)	0.09(2.3)	0.44(11.1)	0.44(11.1)
1/8	1/4	-S-FJ2RT4	1.40(35.6)	0.56(14.2)	0.50(12.7)	0.09(2.3)	0.44(11.1)	0.56(14.3)
1/4	1/8	-S-FJ4RT2	1.29(32.8)	0.38(9.7)	0.60(15.2)	0.19(4.8)	0.56(14.3)	0.50(12.7)
1/4	1/4	-S-FJ4RT4	1.49(37.8)	0.56(14.2)	0.60(15.2)	0.19(4.8)	0.56(14.3)	0.56(14.3)
1/4	3/8	-S-FJ4RT6	1.51(38.4)	0.56(14.2)	0.60(15.2)	0.19(4.8)	0.56(14.3)	0.69(17.5)
1/4	1/2	-S-FJ4RT8	1.76(44.7)	0.75(19.1)	0.60(15.2)	0.19(4.8)	0.56(14.3)	0.87(22.2)
5/16	1/8	-S-FJ5RT2	1.34(34.0)	0.38(9.7)	0.64(16.3)	0.19(4.8)	0.63(15.9)	0.56(14.3)
5/16	1/4	-S-FJ5RT4	1.52(38.6)	0.56(14.2)	0.64(16.3)	0.25(6.4)	0.63(15.9)	0.56(14.3)
3/8	1/8	-S-FJ6RT2	1.39(35.3)	0.38(9.7)	0.66(16.8)	0.19(4.8)	0.69(17.5)	0.63(15.9)
3/8	1/4	-S-FJ6RT4	1.57(39.9)	0.56(14.2)	0.66(16.8)	0.28(7.1)	0.69(17.5)	0.63(15.9)
3/8	3/8	-S-FJ6RT6	1.57(39.9)	0.56(14.2)	0.66(16.8)	0.28(7.1)	0.69(17.5)	0.69(17.5)
3/8	1/2	-S-FJ6RT8	1.82(46.2)	0.75(19.1)	0.66(16.8)	0.28(7.1)	0.69(17.5)	0.87(22.2)
3/8	3/4	-S-FJ6RT12	1.88(47.8)	0.75(19.1)	0.66(16.8)	0.28(7.1)	0.69(17.5)	1.06(27.0)
1/2	1/4	-S-FJ8RT4	1.71(43.4)	0.56(14.2)	0.90(22.9)	0.28(7.1)	0.87(22.2)	0.81(20.6)
1/2	3/8	-S-FJ8RT6	1.71(43.4)	0.56(14.2)	0.90(22.9)	0.38(9.7)	0.87(22.2)	0.81(20.6)
1/2	1/2	-S-FJ8RT8	1.93(49.0)	0.75(19.1)	0.90(22.9)	0.41(10.4)	0.87(22.2)	0.87(22.2)
1/2	3/4	-S-FJ8RT12	1.99(50.5)	0.75(19.1)	0.90(22.9)	0.41(10.4)	0.87(22.2)	1.06(27.0)
5/8	1/2	-S-FJ10RT8	1.93(49.0)	0.75(19.1)	0.96(24.4)	0.47(11.9)	1.00(25.4)	0.94(23.8)
3/4	3/4	-S-FJ12RT12	1.99(50.5)	0.75(19.1)	0.96(24.4)	0.62(15.7)	1.13(28.6)	1.06(27.0)
3/4	1	-S-FJ12RT16	2.25(57.2)	0.94(23.9)	0.96(24.4)	0.62(15.7)	1.13(28.6)	1.37(34.9)
1	3/4	-S-FJ16RT12	2.26(57.4)	0.75(19.1)	1.23(31.2)	0.62(15.7)	1.50(38.1)	1.37(34.9)
1	1	-S-FJ16RT16	2.45(62.2)	0.94(23.9)	1.23(31.2)	0.88(22.4)	1.50(38.1)	1.37(34.9)

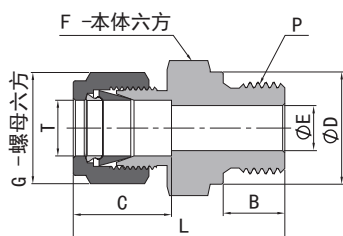

英制 Tube 管			ISO 平行螺纹 (BS)						
T-Tube 管外径 (in.)	P-RS 尺寸	基本 订购号	尺寸, in. (mm)						
			L	B	C	E*	G	F	D
1/8	1/8	-S-FJ2BS2	1.18(30.0)	0.28(7.1)	0.50(12.7)	0.09(2.3)	0.44(11.1)	0.56(14.3)	0.54(13.7)
1/8	1/4	-S-FJ2BS6	1.39(35.3)	0.44(11.2)	0.50(12.7)	0.09(2.3)	0.44(11.1)	0.75(19.1)	0.71(18.0)
1/8	3/8	-S-FJ2BS6	1.43(36.3)	0.44(11.2)	0.50(12.7)	0.09(2.3)	0.44(11.1)	0.87(22.2)	0.86(21.8)
1/4	1/8	-S-FJ4BS2	1.27(32.3)	0.28(7.1)	0.60(15.2)	0.16(4.0)	0.56(14.3)	0.56(14.3)	0.54(13.7)
1/4	1/4	-S-FJ4BS4	1.48(37.6)	0.44(11.2)	0.60(15.2)	0.19(4.8)	0.56(14.3)	0.75(19.1)	0.71(18.0)
1/4	3/8	-S-FJ4BS6	1.53(38.9)	0.44(11.2)	0.60(15.2)	0.19(4.8)	0.56(14.3)	0.87(22.2)	0.86(21.8)
1/4	1/2	-S-FJ4BS8	1.76(44.7)	0.56(14.2)	0.60(15.2)	0.19(4.8)	0.56(14.3)	1.06(27.0)	1.02(25.9)
3/8	1/8	-S-FJ6BS2	1.49(37.8)	0.28(7.1)	0.66(16.8)	0.16(4.0)	0.69(17.5)	0.63(15.9)	0.54(13.7)
3/8	1/4	-S-FJ6BS4	1.54(39.1)	0.44(11.2)	0.66(16.8)	0.23(5.9)	0.69(17.5)	0.75(19.1)	0.71(18.0)
3/8	3/8	-S-FJ6BS6	1.59(40.4)	0.44(11.2)	0.66(16.8)	0.28(7.1)	0.69(17.5)	0.87(22.2)	0.86(21.8)
3/8	1/2	-S-FJ6BS8	1.82(46.2)	0.56(14.2)	0.66(16.8)	0.28(7.1)	0.69(17.5)	1.06(27.0)	1.02(25.9)
1/2	1/4	-S-FJ8BS4	1.68(42.7)	0.44(11.2)	0.90(22.9)	0.23(5.9)	0.87(22.2)	0.81(20.6)	0.71(18.0)
1/2	3/8	-S-FJ8BS6	1.70(43.2)	0.44(11.2)	0.90(22.9)	0.31(7.9)	0.87(22.2)	0.87(22.2)	0.86(21.8)
1/2	1/2	-S-FJ8BS8	1.93(49.0)	0.56(14.2)	0.90(22.9)	0.41(10.4)	0.87(22.2)	1.06(27.0)	1.02(25.9)
3/4	1/2	-S-FJ12BS8	1.93(49.0)	0.56(14.2)	0.96(24.4)	0.47(11.9)	1.13(28.6)	1.06(27.0)	1.02(25.9)
3/4	3/4	-S-FJ12BS12	2.08(52.9)	0.62(15.7)	0.96(24.4)	0.62(15.7)	1.13(28.6)	1.31(33.3)	1.26(32.0)
1	1/2	-S-FJ16BS8	2.19(55.5)	0.56(14.2)	1.23(31.2)	0.47(11.9)	1.50(38.1)	1.37(34.9)	1.02(25.9)
1	3/4	-S-FJ16BS12	2.27(57.7)	0.62(15.7)	1.23(31.2)	0.63(16.0)	1.50(38.1)	1.37(34.9)	1.26(32.0)
1	1	-S-FJ16BS16	2.36(59.9)	0.72(18.3)	1.23(31.2)	0.78(19.8)	1.50(38.1)	1.63(41.3)	1.54(39.1)

◆ 尺寸“E”为最小公称孔口,此孔口在管螺纹端、直螺纹端可能会更大。

▶ 卡套阳螺纹接头

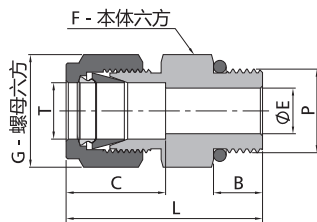
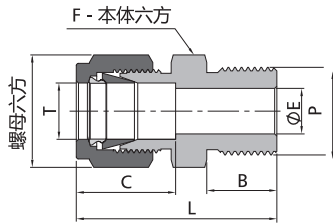
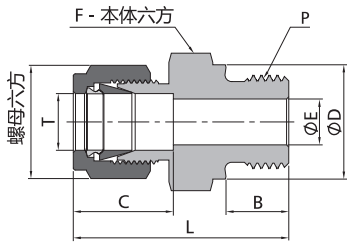

◆ 转接至 SAE J1926-1、ISO 11926-1 和 MS 16142 直螺纹凸台。

英制 Tube 管				ISO 平行螺纹 (BR)					
T-Tube 管外径 (in.)	P-BR 尺寸	基本订购号	尺寸, in. (mm)						
			L	B	C	E*	G	F	D
1/8	1/8	-S-FJ2BR2	1.18(30.0)	0.28(7.1)	0.50(12.7)	0.09(2.3)	0.44(11.1)	0.56(14.3)	0.54(13.8)
1/8	1/4	-S-FJ2BR4	1.39(35.3)	0.44(11.2)	0.50(12.7)	0.09(2.3)	0.44(11.1)	0.75(19.1)	0.70(17.8)
1/4	1/8	-S-FJ4BR2	1.27(32.3)	0.28(7.1)	0.60(15.2)	0.16(4.1)	0.56(14.3)	0.56(14.3)	0.54(13.8)
1/4	1/4	-S-FJ4BR4	1.48(37.6)	0.44(11.2)	0.60(15.2)	0.19(4.8)	0.56(14.3)	0.75(19.1)	0.70(17.8)
1/2	3/8	-S-FJ8BR6	1.79(45.5)	0.44(11.2)	0.90(22.9)	0.31(7.9)	0.87(22.2)	0.87(22.2)	0.86(21.8)
1/2	1/2	-S-FJ8BR8	1.93(49.0)	0.56(14.2)	0.90(22.9)	0.41(10.4)	0.87(22.2)	1.06(27.0)	1.02(25.9)
3/4	1/2	-S-FJ12BR8	1.93(49.0)	0.56(14.2)	0.96(24.4)	0.47(11.9)	1.13(28.6)	1.06(27.0)	1.02(25.9)
3/4	3/4	-S-FJ12BR12	2.08(52.9)	0.62(15.7)	0.96(24.4)	0.62(15.7)	1.13(28.6)	1.31(33.3)	1.26(32.0)
1	1	-S-FJ16BR16	2.36(59.9)	0.72(18.3)	1.23(31.2)	0.78(19.8)	1.50(38.1)	1.63(41.3)	1.53(38.8)

英制 Tube 管				ISO 平行螺纹 (BP)					
T-Tube 管外径 (in.)	P-BP 尺寸	基本订购号	尺寸, in. (mm)						
			L	B	C	E*	G	F	
1/4	3/8	-S-FJ4BP6	1.51(38.4)	0.56(14.2)	0.60(15.2)	0.19(4.8)	0.56(14.3)	0.69(17.5)	
3/8	3/8	-S-FJ6BP6	1.57(39.9)	0.56(14.2)	0.66(16.8)	0.28(7.1)	0.69(17.5)	0.69(17.5)	

英制 Tube 管				SAE/MS 直螺纹 (ST)					
T-Tube 管外径 (in.)	P-SAE 名义尺寸	P-SAE/MS 螺纹规格	基本订购号	尺寸, in. (mm)					
				L	B	C	E*	G	F
1/16	2	5/16-24	-S-FJ1ST5	0.92(23.4)	0.30(7.6)	0.34(8.6)	0.05(1.3)	0.31(7.9)	0.44(11.1)
1/8	2	5/16-24	-S-FJ2ST5	1.18(30.0)	0.30(7.6)	0.50(12.7)	0.09(2.3)	0.44(11.1)	0.44(11.1)
1/8	4	7/16-20	-S-FJ2ST7	1.24(31.5)	0.36(9.1)	0.50(12.7)	0.09(2.3)	0.44(11.1)	0.56(14.3)
1/8	6	9/16-18	-S-FJ2ST9	1.31(33.3)	0.39(9.9)	0.50(12.7)	0.09(2.3)	0.44(11.1)	0.69(17.5)
3/16	3	3/8-24	-S-FJ3ST6	1.20(30.5)	0.30(7.6)	0.54(13.7)	0.12(3.0)	0.50(12.7)	0.50(12.7)
1/4	2	5/16-24	-S-FJ4ST5	1.27(32.3)	0.30(7.6)	0.60(15.2)	0.12(3.0)	0.56(14.3)	0.50(12.7)
1/4	4	7/16-20	-S-FJ4ST7	1.34(34.0)	0.36(9.1)	0.60(15.2)	0.19(4.8)	0.56(14.3)	0.56(14.3)
1/4	6	9/16-18	-S-FJ4ST9	1.40(35.6)	0.39(9.9)	0.60(15.2)	0.19(4.8)	0.56(14.3)	0.69(17.5)
1/4	8	3/4-16	-S-FJ4ST12	1.48(37.6)	0.44(11.2)	0.60(15.2)	0.19(4.8)	0.56(14.3)	0.87(22.2)
1/4	10	7/8-14	-S-FJ4ST14	1.60(40.6)	0.50(12.7)	0.60(15.2)	0.19(4.8)	0.56(14.3)	1.00(25.4)
5/16	5	1/2-20	-S-FJ5ST8	1.37(34.8)	0.36(9.1)	0.64(16.3)	0.25(6.4)	0.63(15.9)	0.63(15.9)
3/8	4	7/16-20	-S-FJ6ST7	1.40(35.6)	0.36(9.1)	0.66(16.8)	0.20(5.1)	0.69(17.5)	0.63(15.9)
3/8	6	9/16-18	-S-FJ6ST9	1.46(37.1)	0.39(9.9)	0.66(16.8)	0.28(7.1)	0.69(17.5)	0.69(17.5)
3/8	8	3/4-16	-S-FJ6ST12	1.54(39.1)	0.44(11.2)	0.66(16.8)	0.28(7.1)	0.69(17.5)	0.87(22.2)
3/8	10	7/8-14	-S-FJ6ST14	1.66(42.2)	0.50(12.7)	0.66(16.8)	0.28(7.1)	0.69(17.5)	1.00(25.4)
1/2	6	9/16-18	-S-FJ8ST9	1.54(39.1)	0.39(9.9)	0.90(22.9)	0.28(7.1)	0.87(22.2)	0.81(20.6)
1/2	8	3/4-16	-S-FJ8ST12	1.65(41.9)	0.44(11.2)	0.90(22.9)	0.41(10.4)	0.87(22.2)	0.87(22.2)
1/2	10	7/8-14	-S-FJ8ST14	1.77(45.0)	0.50(12.7)	0.90(22.9)	0.41(10.4)	0.87(22.2)	1.00(25.4)
1/2	12	1 1/16-12	-S-FJ8ST17	1.93(49.0)	0.59(15.0)	0.90(22.9)	0.41(10.4)	0.87(22.2)	1.25(31.8)
5/8	8	3/4-16	-S-FJ10ST12	1.65(41.9)	0.44(11.2)	0.96(24.4)	0.42(10.7)	1.00(25.4)	0.94(23.8)
5/8	10	7/8-14	-S-FJ10ST14	1.78(45.2)	0.50(12.7)	0.96(24.4)	0.50(12.7)	1.00(25.4)	1.00(25.4)
3/4	8	3/4-16	-S-FJ12ST12	1.81(46.0)	0.44(11.2)	0.96(24.4)	0.42(10.7)	1.13(28.6)	1.06(27.0)
3/4	12	1 1/16-12	-S-FJ12ST17	1.93(49.0)	0.59(15.0)	0.96(24.4)	0.62(15.7)	1.13(28.6)	1.25(31.8)
3/4	16	1 5/16-12	-S-FJ12ST21	1.96(49.8)	0.59(15.0)	0.96(24.4)	0.63(16.0)	1.13(28.6)	1.50(38.1)
7/8	14	1 3/16-12	-S-FJ14ST19	1.93(49.0)	0.59(15.0)	1.02(25.9)	0.72(18.3)	1.25(31.8)	1.37(34.9)
1	12	1 1/16-12	-S-FJ16ST17	2.10(53.3)	0.59(15.0)	1.23(31.2)	0.66(16.8)	1.50(38.1)	1.37(34.9)
1	16	1 5/16-12	-S-FJ16ST21	2.14(54.4)	0.59(15.0)	1.23(31.2)	0.88(22.4)	1.50(38.1)	1.50(38.1)
1 1/4	20	1 5/8-12	-S-FJ20ST26	2.69(68.3)	0.59(15.0)	1.62(41.1)	1.09(27.7)	1.87(47.6)	1.87(47.6)
1 1/2	24	1 7/8-12	-S-FJ24ST30	3.06(77.7)	0.59(15.0)	1.97(50.0)	1.34(34.0)	2.25(57.2)	2.13(54.0)

◆ 尺寸“E”为最小公称孔口,此孔口在管螺纹端、直螺纹端可能会更大。

▶ 卡套阳螺纹接头

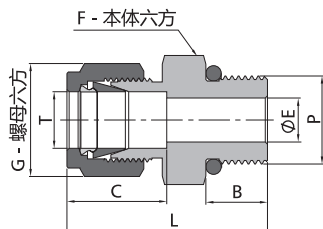

英制 Tube 管				SAE/MS 直螺纹 (ST)					
T-Tube 管外径 (in.)	P-SAE 名义 尺寸	P-SAE/MS 螺纹规格	基本 订购号	尺寸, in. (mm)					
				L	B	C	E*	G	F
1/4	4	7/16-20	-S-FJ4ST7	2.26(57.4)	0.36(9.1)	0.60(15.2)	0.19(4.8)	0.56(14.3)	0.56(14.3)
1/2	8	3/4-16	-S-FJ8ST12	3.01(76.5)	0.44(11.2)	0.90(22.9)	0.41(10.4)	0.87(22.2)	0.87(22.2)

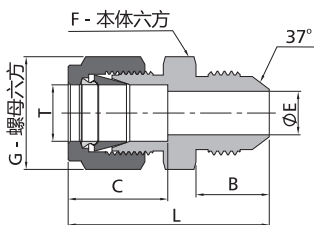

英制 Tube 管			37° 扩口 (AN)					
T-Tube 管外径 (in.)	AN Tube 管扩口尺寸 (in.)	基本 订购号	尺寸, in. (mm)					
			L	B	C	E*	G	F
1/16	1/8	-S-FJ1AN2	1.07(27.2)	0.45(11.4)	0.34(8.6)	0.05(1.3)	0.31(7.9)	0.44(11.1)
1/8	1/8	-S-FJ2AN2	1.27(32.3)	0.45(11.4)	0.50(12.7)	0.06(1.5)	0.44(11.1)	0.44(11.1)
1/8	1/4	-S-FJ2AN4	1.38(35.1)	0.55(14.0)	0.50(12.7)	0.09(2.3)	0.44(11.1)	0.50(12.7)
3/16	3/16	-S-FJ3AN3	1.32(33.5)	0.48(12.2)	0.54(13.7)	0.12(3.0)	0.50(12.7)	0.44(11.1)
1/4	1/4	-S-FJ4AN4	1.48(37.6)	0.55(14.0)	0.60(15.2)	0.17(4.3)	0.56(14.3)	0.50(12.7)
5/16	5/16	-S-FJ5AN5	1.51(38.4)	0.55(14.0)	0.64(16.2)	0.23(5.8)	0.63(15.9)	0.56(14.3)
3/8	1/4	-S-FJ6AN4	1.56(39.6)	0.55(14.0)	0.66(16.8)	0.17(4.3)	0.69(17.5)	0.63(15.9)
3/8	3/8	-S-FJ6AN6	1.56(39.6)	0.56(14.1)	0.66(16.8)	0.28(7.1)	0.69(17.5)	0.63(15.9)
1/2	1/2	-S-FJ8AN8	1.81(46.0)	0.66(16.7)	0.90(22.8)	0.39(9.9)	0.87(22.2)	0.81(20.6)
5/8	5/8	-S-FJ10AN10	1.93(49.0)	0.76(19.3)	0.96(24.5)	0.48(12.3)	1.00(25.4)	0.94(23.8)
3/4	3/4	-S-FJ12AN12	2.10(53.3)	0.86(21.9)	0.96(24.4)	0.61(15.5)	1.13(28.6)	1.13(28.6)
1	1	-S-FJ16AN16	2.42(61.5)	0.91(23.1)	1.23(31.2)	0.84(21.3)	1.50(38.1)	1.37(34.9)

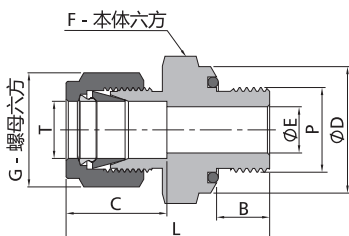

英制 Tube 管				SAE/MS 直螺纹 (ST)						
T-Tube 管外径 (in.)	P-SAE 名义 尺寸	P-SAE/MS 螺纹规格	基本 订购号	尺寸, in. (mm)						
				L	B	C	E*	G	F	D
1/16	2	5/16-24	-S-FJ1STO5	1.05(26.7)	0.34(8.6)	0.34(8.6)	0.05(1.3)	0.31(7.9)	0.56(14.3)	0.55(14.0)
1/8	2	5/16-24	-S-FJ2STO5	1.29(32.8)	0.34(8.6)	0.50(12.7)	0.09(2.3)	0.44(11.1)	0.56(14.3)	0.55(14.0)
3/16	3	3/8-24	-S-FJ3STO6	1.35(34.3)	0.38(9.7)	0.54(13.7)	0.12(3.0)	0.50(12.7)	0.63(15.9)	0.62(15.7)
1/4	4	7/16-20	-S-FJ4STO7	1.51(38.4)	0.41(10.4)	0.60(15.2)	0.19(4.8)	0.56(14.3)	0.75(19.1)	0.74(18.8)
5/16	5	1/2-20	-S-FJ5STO8	1.60(40.6)	0.44(11.2)	0.64(16.3)	0.25(6.4)	0.63(15.9)	0.87(22.2)	0.86(21.8)
3/8	6	9/16-18	-S-FJ6STO9	1.67(42.4)	0.47(11.9)	0.66(16.8)	0.28(7.1)	0.69(17.5)	0.94(23.8)	0.93(23.6)
1/2	8	3/4-16	-S-FJ8STO12	1.81(46.0)	0.47(11.9)	0.90(22.9)	0.41(10.4)	0.87(22.2)	1.13(28.6)	1.12(28.4)
3/4	12	1 1/16-12	-S-FJ12STO17	2.06(52.3)	0.56(14.2)	0.96(24.4)	0.62(15.7)	1.13(28.6)	1.50(38.1)	1.49(37.8)
1	16	1 5/16-12	-S-FJ16STO21	2.29(58.2)	0.56(14.2)	1.23(31.2)	0.88(22.4)	1.50(38.1)	1.75(44.5)	1.74(44.2)

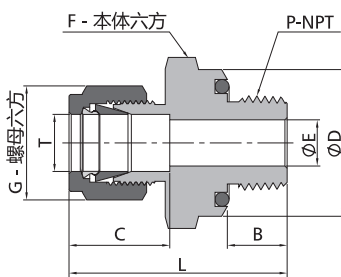

英制 Tube 管			O 形圈密封						
T-Tube 管外径 (in.)	P-NPT 尺寸	基本 订购号	尺寸, in. (mm)						
			L	B	C	E*	G	F	D
1/8	1/8	-S-FJ2NO2	1.29(32.8)	0.28(7.1)	0.34(8.6)	0.09(2.3)	0.47(11.9)	0.75(19.1)	0.74(18.8)
1/4	1/8	-S-FJ4NO2	1.38(35.1)	0.28(7.1)	0.60(15.2)	0.19(4.8)	0.56(14.3)	0.75(19.1)	0.74(18.8)
1/4	1/4	-S-FJ4NO4	1.51(38.4)	0.38(9.7)	0.60(15.2)	0.19(4.8)	0.56(14.3)	0.94(23.8)	0.93(23.6)
3/8	1/4	-S-FJ6NO4	1.57(39.9)	0.38(9.7)	0.66(16.8)	0.28(7.1)	0.69(17.5)	0.94(23.8)	0.93(23.6)
3/8	3/8	-S-FJ6NO6	1.63(41.4)	0.41(10.4)	0.66(16.8)	0.28(7.1)	0.69(17.5)	1.13(28.6)	1.12(28.4)
3/8	1/2	-S-FJ6NO8	1.85(47.0)	0.53(13.5)	0.66(16.8)	0.28(7.1)	0.69(17.5)	1.31(33.3)	1.30(33.0)
1/2	1/2	-S-FJ8NO8	1.96(49.8)	0.53(13.5)	0.90(22.9)	0.41(10.4)	0.87(22.2)	1.31(33.3)	1.30(33.0)

◆ 尺寸“E”为最小公称孔口,此孔口在管螺纹端、直螺纹端可能会更大。

▶ 卡套阳螺纹接头

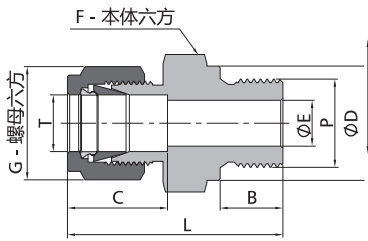

英制 Tube 管			公制螺纹 (MR)						
T-Tube 管外径 (in.)	P- 公制 螺纹尺寸	基本 订购号	尺寸, in. (mm)						
			L	B	C	E*	G	F	D
1/8	M14 x 1.5	-S-FJ2MR14	1.44(36.7)	0.47(12.0)	0.50(12.7)	0.09(2.3)	0.44(11.1)	0.75(19.1)	0.75(19.0)
1/8	M16 x 1.5	-S-FJ2MR16	1.48(37.5)	0.47(12.0)	0.50(12.7)	0.09(2.3)	0.44(11.1)	0.87(22.2)	0.83(21.0)
1/8	M18 x 1.5	-S-FJ2MR18	1.52(38.5)	0.47(12.0)	0.50(12.7)	0.09(2.3)	0.44(11.1)	0.94(23.8)	0.91(23.0)
1/8	M20 x 1.5	-S-FJ2MR20	1.62(41.1)	0.55(14.0)	0.50(12.7)	0.09(2.3)	0.44(11.1)	1.00(25.4)	0.98(25.0)
1/4	M14 x 1.5	-S-FJ4MR14	1.50(38.0)	0.47(12.0)	0.60(15.2)	0.19(4.8)	0.56(14.3)	0.75(19.1)	0.75(19.0)
1/4	M16 x 1.5	-S-FJ4MR16	1.57(39.9)	0.47(12.0)	0.60(15.2)	0.19(4.8)	0.56(14.3)	0.87(22.2)	0.83(21.0)
1/4	M18 x 1.5	-S-FJ4MR18	1.61(40.8)	0.47(12.0)	0.60(15.2)	0.19(4.8)	0.56(14.3)	0.94(23.8)	0.91(23.0)
1/4	M20 x 1.5	-S-FJ4MR20	1.72(43.6)	0.55(14.0)	0.60(15.2)	0.19(4.8)	0.56(14.3)	1.00(25.4)	0.98(25.0)
3/8	M14 x 1.5	-S-FJ6MR14	1.63(41.3)	0.47(12.0)	0.66(16.8)	0.28(7.1)	0.69(17.5)	0.75(19.1)	0.75(19.0)
3/8	M16 x 1.5	-S-FJ6MR16	1.63(41.3)	0.47(12.0)	0.66(16.8)	0.28(7.1)	0.69(17.5)	0.87(22.2)	0.83(21.0)
3/8	M18 x 1.5	-S-FJ6MR18	1.65(41.8)	0.47(12.0)	0.66(16.8)	0.28(7.1)	0.69(17.5)	0.94(23.8)	0.91(23.0)
3/8	M20 x 1.5	-S-FJ6MR20	1.78(45.1)	0.55(14.0)	0.66(16.8)	0.28(7.1)	0.69(17.5)	1.00(25.4)	0.98(25.0)
1/2	M16 x 1.5	-S-FJ8MR16	1.73(44.0)	0.47(12.0)	0.90(22.8)	0.35(9.0)	0.87(22.2)	0.87(22.2)	0.83(21.0)
1/2	M18 x 1.5	-S-FJ8MR18	1.73(44.0)	0.47(12.0)	0.90(22.9)	0.39(10.0)	0.87(22.2)	0.94(23.8)	0.91(23.0)
1/2	M20 x 1.5	-S-FJ8MR20	1.89(47.9)	0.55(14.0)	0.90(22.9)	0.41(10.4)	0.87(22.2)	1.00(25.4)	0.98(25.0)
1/2	M22 x 1.5	-S-FJ8MR22	1.91(48.5)	0.55(14.0)	0.90(22.9)	0.41(10.4)	0.87(22.2)	1.06(27.0)	1.06(27.0)

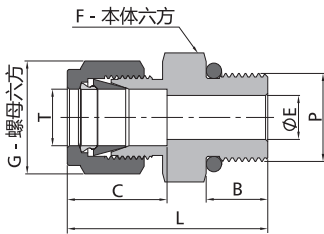

◆ 转接至 ISO 6149-1 直螺纹凸台。

英制 Tube 管			公制螺纹 (M0)					
T-Tube 管外径 (in.)	P- 公制 螺纹尺寸	基本 订购号	尺寸, in. (mm)					
			L	B	C	E*	G	F
1/4	M14X1.5	-S-FJ4MO14	1.39(35.2)	0.43(11.0)	0.60(15.2)	0.19(4.8)	0.56(14.3)	0.75(19.1)
3/8	M14X1.5	-S-FJ6MO14	1.44(36.7)	0.43(11.0)	0.66(16.8)	0.28(7.1)	0.69(17.5)	0.75(19.1)
3/8	M20X1.5	-S-FJ6MO20	1.62(41.2)	0.55(14.0)	0.66(16.8)	0.28(7.1)	0.69(17.5)	1.06(27.0)
1/2	M14X1.5	-S-FJ8MO14	1.58(40.2)	0.43(11.0)	0.90(22.9)	0.30(7.5)	0.87(22.2)	0.81(20.6)
1/2	M20X1.5	-S-FJ8MO20	1.73(44.0)	0.55(14.0)	0.90(22.9)	0.41(10.4)	0.87(22.2)	1.06(27.0)

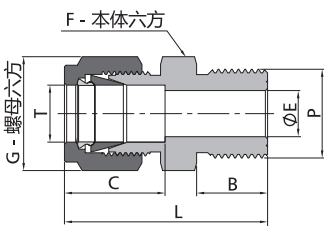

英制 Tube 管			公制螺纹 (MS)					
T-Tube 管外径 (in.)	P- 公制 螺纹尺寸	基本 订购号	尺寸, in. (mm)					
			L	B	C	E*	G	F
1/16	M5 x 0.8	-S-FJ1MS5	0.86(21.8)	0.31(8.0)	0.34(8.6)	0.05(1.3)	0.31(7.9)	0.31(7.9)
1/8	M14 x 1.5	-S-FJ2MS14	1.37(34.8)	0.51(13.0)	0.50(12.7)	0.09(2.3)	0.44(11.1)	0.63(15.9)
1/8	M16 x 1.5	-S-FJ2MS16	1.41(35.8)	0.55(14.0)	0.50(12.7)	0.09(2.3)	0.44(11.1)	0.69(17.5)
1/8	M18 x 1.5	-S-FJ2MS18	1.46(37.2)	0.59(15.0)	0.50(12.7)	0.09(2.3)	0.44(11.1)	0.75(19.1)
1/8	M20 x 1.5	-S-FJ2MS20	1.50(38.1)	0.63(16.0)	0.50(12.7)	0.09(2.3)	0.44(11.1)	0.87(22.2)
1/4	M14 x 1.5	-S-FJ4MS14	1.45(36.9)	0.51(13.0)	0.60(15.2)	0.19(4.8)	0.56(14.3)	0.63(15.9)
1/4	M16 x 1.5	-S-FJ4MS16	1.50(38.1)	0.55(14.0)	0.60(15.2)	0.19(4.8)	0.56(14.3)	0.69(17.5)
1/4	M18 x 1.5	-S-FJ4MS18	1.56(39.5)	0.59(15.0)	0.60(15.2)	0.19(4.8)	0.56(14.3)	0.75(19.1)
1/4	M20 x 1.5	-S-FJ4MS20	1.60(40.7)	0.63(16.0)	0.60(15.2)	0.19(4.8)	0.56(14.3)	0.87(22.2)
3/8	M10 x 1.0	-S-FJ6MS10	1.43(36.4)	0.43(11.0)	0.66(16.8)	0.19(4.8)	0.69(17.5)	0.63(15.9)
3/8	M14 x 1.5	-S-FJ6MS14	1.55(39.3)	0.51(13.0)	0.66(16.8)	0.28(7.1)	0.69(17.5)	0.63(15.9)
3/8	M16 x 1.5	-S-FJ6MS16	1.56(39.7)	0.55(14.0)	0.66(16.8)	0.28(7.1)	0.69(17.5)	0.69(17.5)
3/8	M18 x 1.5	-S-FJ6MS18	1.63(41.5)	0.59(15.0)	0.66(16.8)	0.28(7.1)	0.69(17.5)	0.75(19.1)
3/8	M20 x 1.5	-S-FJ6MS20	1.67(42.3)	0.63(16.0)	0.66(16.8)	0.28(7.1)	0.69(17.5)	0.87(22.2)
1/2	M16 x 1.5	-S-FJ8MS16	1.70(43.2)	0.55(14.0)	0.90(22.9)	0.33(8.4)	0.87(22.2)	0.81(20.6)
1/2	M18 x 1.5	-S-FJ8MS18	1.72(43.7)	0.59(15.0)	0.90(22.9)	0.38(9.6)	0.87(22.2)	0.81(20.6)
1/2	M20 x 1.5	-S-FJ8MS20	1.77(44.9)	0.63(16.0)	0.90(22.9)	0.41(10.4)	0.87(22.2)	0.87(22.2)
1/2	M22 x 1.5	-S-FJ8MS22	1.85(47.0)	0.67(17.0)	0.90(22.9)	0.41(10.4)	0.87(22.2)	0.94(23.8)

◆ 尺寸“E”为最小公称孔口,此孔口在管螺纹端、直螺纹端可能会更大。

▶ 卡套阳螺纹接头

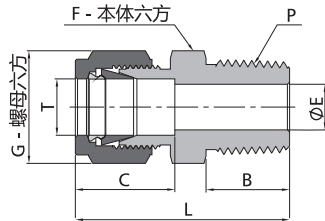

公制 Tube管				NPT 螺纹					
T-Tube 管外径 (mm)	P-NPT 尺寸	基本 订购号	尺寸, mm (in.)						
			L	B	C	E*	G	F	
2	1/8	-S-MJ2N2	30.5(1.20)	9.7(0.38)	12.9(0.51)	1.7(0.07)	12.0(0.47)	12.0(0.47)	
3	1/8	-S-MJ3N2	30.5(1.20)	9.7(0.38)	12.9(0.51)	2.4(0.09)	12.0(0.47)	12.0(0.47)	
3	1/4	-S-MJ3N4	35.6(1.40)	14.2(0.56)	12.9(0.51)	2.4(0.09)	12.0(0.47)	14.0(0.55)	
4	1/8	-S-MJ4N2	31.2(1.23)	9.7(0.38)	13.7(0.54)	2.4(0.09)	12.0(0.47)	12.0(0.47)	
4	1/4	-S-MJ4N4	36.3(1.43)	14.2(0.56)	13.7(0.54)	2.4(0.09)	12.0(0.47)	14.0(0.55)	
6	1/8	-S-MJ6N2	32.8(1.29)	9.7(0.38)	15.3(0.60)	4.8(0.19)	14.0(0.55)	14.0(0.55)	
6	1/4	-S-MJ6N4	37.9(1.49)	14.2(0.56)	15.3(0.60)	4.8(0.19)	14.0(0.55)	14.0(0.55)	
6	3/8	-S-MJ6N6	38.4(1.51)	14.2(0.56)	15.3(0.60)	4.8(0.19)	14.0(0.55)	18.0(0.71)	
6	1/2	-S-MJ6N8	44.7(1.76)	19.1(0.75)	15.3(0.60)	4.8(0.19)	14.0(0.55)	22.0(0.87)	
8	1/8	-S-MJ8N2	34.2(1.35)	9.7(0.38)	16.2(0.64)	4.8(0.19)	16.0(0.63)	15.0(0.59)	
8	1/4	-S-MJ8N4	38.7(1.52)	14.2(0.56)	16.2(0.64)	6.4(0.25)	16.0(0.63)	15.0(0.59)	
8	3/8	-S-MJ8N6	39.3(1.55)	14.2(0.56)	16.2(0.64)	6.4(0.25)	16.0(0.63)	18.0(0.71)	
8	1/2	-S-MJ8N8	45.6(1.80)	19.1(0.75)	16.2(0.64)	6.4(0.25)	16.0(0.63)	22.0(0.87)	
10	1/8	-S-MJ10N2	36.3(1.43)	9.7(0.38)	17.2(0.68)	4.8(0.19)	19.0(0.75)	18.0(0.71)	
10	1/4	-S-MJ10N4	40.9(1.61)	14.2(0.56)	17.2(0.68)	7.1(0.28)	19.0(0.75)	18.0(0.71)	
10	3/8	-S-MJ10N6	40.9(1.61)	14.2(0.56)	17.2(0.68)	7.9(0.31)	19.0(0.75)	18.0(0.71)	
10	1/2	-S-MJ10N8	45.8(1.80)	19.1(0.75)	17.2(0.68)	7.9(0.31)	19.0(0.75)	22.0(0.87)	
10	3/4	-S-MJ10N12	48.0(1.89)	19.1(0.75)	17.2(0.68)	7.9(0.31)	19.0(0.75)	27.0(1.06)	
10	1	-S-MJ10N16	54.6(2.15)	23.9(0.94)	17.2(0.68)	7.9(0.31)	19.0(0.75)	35.0(1.38)	
12	1/8	-S-MJ12N2	38.8(1.53)	9.7(0.38)	22.8(0.90)	4.8(0.19)	22.0(0.87)	22.0(0.87)	
12	1/4	-S-MJ12N4	43.4(1.71)	14.2(0.56)	22.8(0.90)	7.1(0.28)	22.0(0.87)	22.0(0.87)	
12	3/8	-S-MJ12N6	43.4(1.71)	14.2(0.56)	22.8(0.90)	9.5(0.37)	22.0(0.87)	22.0(0.87)	
12	1/2	-S-MJ12N8	49.0(1.93)	19.1(0.75)	22.8(0.90)	9.5(0.37)	22.0(0.87)	22.0(0.87)	
12	3/4	-S-MJ12N12	50.5(1.99)	19.1(0.75)	22.8(0.90)	9.5(0.37)	22.0(0.87)	27.0(1.06)	
14	1/8	-S-MJ14N2	39.9(1.57)	9.7(0.38)	24.4(0.96)	4.8(0.19)	25.0(0.98)	24.0(0.94)	
14	1/4	-S-MJ14N4	44.1(1.74)	14.2(0.56)	24.4(0.96)	7.1(0.28)	25.0(0.98)	24.0(0.94)	
14	3/8	-S-MJ14N6	44.1(1.74)	14.2(0.56)	24.4(0.96)	9.5(0.37)	25.0(0.98)	24.0(0.94)	
14	1/2	-S-MJ14N8	49.0(1.93)	19.1(0.75)	24.4(0.96)	11.1(0.44)	25.0(0.98)	24.0(0.94)	
14	3/4	-S-MJ14N12	49.1(1.93)	19.1(0.75)	24.4(0.96)	11.1(0.44)	25.0(0.98)	27.0(1.06)	
15	1/2	-S-MJ15N8	49.0(1.93)	19.1(0.75)	24.4(0.96)	11.9(0.47)	25.0(0.98)	24.0(0.94)	
15	3/4	-S-MJ15N12	50.5(1.99)	19.1(0.75)	24.4(0.96)	11.9(0.47)	25.0(0.98)	27.0(1.06)	
15	1	-S-MJ15N16	57.1(2.25)	23.9(0.94)	24.4(0.96)	11.9(0.47)	25.0(0.98)	35.0(1.38)	
16	1/4	-S-MJ16N4	44.1(1.74)	14.2(0.56)	24.4(0.96)	7.1(0.28)	25.0(0.98)	24.0(0.94)	
16	3/8	-S-MJ16N6	44.1(1.74)	14.2(0.56)	24.4(0.96)	9.5(0.37)	25.0(0.98)	24.0(0.94)	
16	1/2	-S-MJ16N8	49.0(1.93)	19.1(0.75)	24.4(0.96)	11.9(0.47)	25.0(0.98)	24.0(0.94)	
16	3/4	-S-MJ16N12	50.5(1.99)	19.1(0.75)	24.4(0.96)	12.7(0.5)	25.0(0.98)	27.0(1.06)	
18	3/8	-S-MJ18N6	45.6(1.80)	14.2(0.56)	24.4(0.96)	9.5(0.37)	30.0(1.18)	27.0(1.06)	
18	1/2	-S-MJ18N8	50.5(1.99)	19.1(0.75)	24.4(0.96)	11.9(0.47)	30.0(1.18)	27.0(1.06)	
18	3/4	-S-MJ18N12	50.5(1.99)	19.1(0.75)	24.4(0.96)	15.1(0.59)	30.0(1.18)	27.0(1.06)	
20	1/2	-S-MJ20N8	52.3(2.06)	19.1(0.75)	26.0(1.02)	11.9(0.47)	32.0(1.26)	30.0(1.18)	
20	3/4	-S-MJ20N12	52.3(2.06)	19.1(0.75)	26.0(1.02)	15.9(0.63)	32.0(1.26)	30.0(1.18)	
20	1	-S-MJ20N16	57.1(2.25)	23.9(0.94)	26.0(1.02)	15.9(0.63)	32.0(1.26)	35.0(1.38)	
22	1/2	-S-MJ22N8	52.3(2.06)	19.1(0.75)	26.0(1.02)	11.9(0.47)	32.0(1.26)	30.0(1.18)	
22	3/4	-S-MJ22N12	52.3(2.06)	19.1(0.75)	26.0(1.02)	15.9(0.63)	32.0(1.26)	30.0(1.18)	
22	1	-S-MJ22N16	57.1(2.25)	23.9(0.94)	26.0(1.02)	18.3(0.72)	32.0(1.26)	35.0(1.38)	
25	1/2	-S-MJ25N8	57.5(2.26)	19.1(0.75)	31.3(1.23)	11.9(0.47)	38.0(1.50)	35.0(1.38)	
25	3/4	-S-MJ25N12	57.5(2.26)	19.1(0.75)	31.3(1.23)	15.9(0.63)	38.0(1.50)	35.0(1.38)	
25	1	-S-MJ25N16	62.3(2.45)	23.9(0.94)	31.3(1.23)	21.8(0.86)	38.0(1.50)	35.0(1.38)	
28	1	-S-MJ28N16	72.4(2.85)	23.9(0.94)	36.6(1.44)	21.8(0.86)	46.0(1.81)	41.0(1.61)	
28	1 1/4	-S-MJ28N20	73.1(2.88)	23.9(0.94)	36.6(1.44)	21.8(0.86)	46.0(1.81)	46.0(1.81)	
30	1 1/4	-S-MJ30N20	77.2(3.04)	23.9(0.94)	39.6(1.56)	26.2(1.03)	50.0(1.97)	46.0(1.81)	
32	1 1/4	-S-MJ32N20	79.6(3.13)	23.9(0.94)	42.0(1.65)	28.6(1.13)	50.0(1.97)	46.0(1.81)	
38	1 1/2	-S-MJ32N24	91.6(3.61)	26.2(1.03)	49.4(1.94)	33.7(1.33)	60.0(2.36)	55.0(2.17)	

◆ 尺寸“E”为最小公称孔口,此孔口在管螺纹端、直螺纹端可能会更大。

▶ 卡套阳螺纹接头

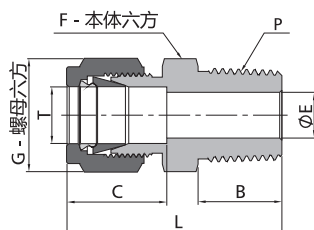

公制 Tube 管			ISO 锥螺纹 (RT)					
T-Tube 管外径 (mm)	P-RT 尺寸	基本 订购号	尺寸, mm (in.)					
			L	B	C	E*	G	F
2	1/8	-S-MJ2RT2	30.5(1.20)	9.7(0.38)	12.9(0.51)	1.7(0.07)	12.0(0.47)	12.0(0.47)
3	1/8	-S-MJ3RT2	30.5(1.20)	9.7(0.38)	12.9(0.51)	2.4(0.09)	12.0(0.47)	12.0(0.47)
3	1/4	-S-MJ3RT4	35.6(1.40)	14.2(0.56)	12.9(0.51)	2.4(0.09)	12.0(0.47)	14.0(0.55)
4	1/8	-S-MJ4RT2	31.2(1.23)	9.7(0.38)	13.7(0.54)	2.4(0.09)	12.0(0.47)	12.0(0.47)
4	1/4	-S-MJ4RT4	36.3(1.43)	14.2(0.56)	13.7(0.54)	2.4(0.09)	12.0(0.47)	14.0(0.55)
6	1/8	-S-MJ6RT2	32.8(1.29)	9.7(0.38)	15.3(0.60)	4.8(0.19)	14.0(0.55)	14.0(0.55)
6	1/4	-S-MJ6RT4	37.9(1.49)	14.2(0.56)	15.3(0.60)	4.8(0.19)	14.0(0.55)	14.0(0.55)
6	3/8	-S-MJ6RT6	38.4(1.51)	14.2(0.56)	15.3(0.60)	4.8(0.19)	14.0(0.55)	18.0(0.71)
6	1/2	-S-MJ6RT8	44.7(1.76)	19.1(0.75)	15.3(0.60)	4.8(0.19)	14.0(0.55)	22.0(0.87)
8	1/8	-S-MJ8RT2	34.2(1.35)	9.7(0.38)	16.2(0.64)	4.8(0.19)	16.0(0.63)	15.0(0.59)
8	1/4	-S-MJ8RT4	38.7(1.52)	14.2(0.56)	16.2(0.64)	6.4(0.25)	16.0(0.63)	15.0(0.59)
8	3/8	-S-MJ8RT6	39.2(1.54)	14.2(0.56)	16.2(0.64)	6.4(0.25)	16.0(0.63)	18.0(0.71)
8	1/2	-S-MJ8RT8	45.6(1.80)	19.1(0.75)	16.2(0.64)	6.4(0.25)	16.0(0.63)	22.0(0.87)
10	1/8	-S-MJ10RT2	36.3(1.43)	9.7(0.38)	17.2(0.68)	4.8(0.19)	19.0(0.75)	18.0(0.71)
10	1/4	-S-MJ10RT4	40.9(1.61)	14.2(0.56)	17.2(0.68)	7.1(0.28)	19.0(0.75)	18.0(0.71)
10	3/8	-S-MJ10RT6	40.9(1.61)	14.2(0.56)	17.2(0.68)	7.9(0.31)	19.0(0.75)	18.0(0.71)
10	1/2	-S-MJ10RT8	46.5(1.83)	19.1(0.75)	17.2(0.68)	7.9(0.31)	19.0(0.75)	22.0(0.87)
10	3/4	-S-MJ10RT12	48.0(1.89)	19.1(0.75)	17.2(0.68)	7.9(0.31)	19.0(0.75)	27.0(1.06)
12	1/8	-S-MJ12RT2	38.9(1.53)	9.7(0.38)	22.8(0.90)	4.8(0.19)	22.0(0.87)	22.0(0.87)
12	1/4	-S-MJ12RT4	43.4(1.71)	14.2(0.56)	22.8(0.90)	7.1(0.28)	22.0(0.87)	22.0(0.87)
12	3/8	-S-MJ12RT6	43.4(1.71)	14.2(0.56)	22.8(0.90)	9.5(0.37)	22.0(0.87)	22.0(0.87)
12	1/2	-S-MJ12RT8	49.0(1.93)	19.1(0.75)	22.8(0.90)	9.5(0.37)	22.0(0.87)	22.0(0.87)
12	3/4	-S-MJ12RT12	50.5(1.99)	19.1(0.75)	22.8(0.90)	9.5(0.37)	22.0(0.87)	27.0(1.06)
14	1/8	-S-MJ14RT2	39.9(1.57)	9.7(0.38)	24.4(0.96)	4.8(0.19)	25.0(0.98)	24.0(0.94)
14	1/4	-S-MJ14RT4	44.1(1.74)	14.2(0.56)	24.4(0.96)	7.1(0.28)	25.0(0.98)	24.0(0.94)
14	3/8	-S-MJ14RT6	44.1(1.74)	14.2(0.56)	24.4(0.96)	9.5(0.37)	25.0(0.98)	24.0(0.94)
14	1/2	-S-MJ14RT8	49.0(1.93)	19.1(0.75)	24.4(0.96)	11.1(0.44)	25.0(0.98)	24.0(0.94)
14	3/4	-S-MJ14RT12	50.5(1.99)	19.1(0.75)	24.4(0.96)	11.1(0.44)	25.0(0.98)	27.0(1.06)
15	1/2	-S-MJ15RT8	49.0(1.93)	19.1(0.75)	24.4(0.96)	11.9(0.47)	25.0(0.98)	24.0(0.94)
16	1/4	-S-MJ16RT4	44.1(1.74)	14.2(0.56)	24.4(0.96)	7.1(0.28)	25.0(0.98)	24.0(0.94)
16	3/8	-S-MJ16RT6	44.1(1.74)	14.2(0.56)	24.4(0.96)	9.5(0.37)	25.0(0.98)	24.0(0.94)
16	1/2	-S-MJ16RT8	49.0(1.93)	19.1(0.75)	24.4(0.96)	11.9(0.47)	25.0(0.98)	24.0(0.94)
16	3/4	-S-MJ16RT12	50.5(1.99)	19.1(0.75)	24.4(0.96)	12.7(0.5)	25.0(0.98)	27.0(1.06)
18	1/2	-S-MJ18RT8	50.5(1.99)	19.1(0.75)	24.4(0.96)	11.9(0.47)	30.0(1.18)	27.0(1.06)
18	3/4	-S-MJ18RT12	50.5(1.99)	19.1(0.75)	24.4(0.96)	15.1(0.59)	30.0(1.18)	27.0(1.06)
20	1/2	-S-MJ20RT8	52.3(2.06)	19.1(0.75)	26.0(1.02)	11.9(0.47)	32.0(1.26)	30.0(1.18)
20	3/4	-S-MJ20RT12	52.3(2.06)	19.1(0.75)	26.0(1.02)	15.9(0.63)	32.0(1.26)	30.0(1.18)
22	3/4	-S-MJ22RT12	52.3(2.06)	19.1(0.75)	26.0(1.02)	15.9(0.63)	32.0(1.26)	30.0(1.18)
22	1	-S-MJ22RT16	57.1(2.25)	23.9(0.94)	26.0(1.02)	18.3(0.72)	32.0(1.26)	35.0(1.38)
25	1/2	-S-MJ25RT8	57.5(2.26)	19.1(0.75)	31.3(1.23)	11.9(0.47)	38.0(1.50)	35.0(1.38)
25	3/4	-S-MJ25RT12	57.5(2.26)	19.1(0.75)	31.3(1.23)	15.9(0.63)	38.0(1.50)	35.0(1.38)
25	1	-S-MJ25RT16	62.3(2.45)	23.9(0.94)	31.3(1.23)	21.8(0.86)	38.0(1.50)	35.0(1.38)
28	1	-S-MJ28RT16	72.4(2.85)	23.9(0.94)	36.6(1.44)	21.8(0.86)	46.0(1.81)	41.0(1.61)
28	1 1/4	-S-MJ28RT20	73.1(2.88)	23.9(0.94)	36.6(1.44)	21.8(0.86)	46.0(1.81)	46.0(1.81)
30	1 1/4	-S-MJ30RT20	77.2(3.04)	23.9(0.94)	39.6(1.56)	26.2(1.03)	50.0(1.97)	46.0(1.81)
32	1 1/4	-S-MJ32RT20	79.6(3.13)	23.9(0.94)	42.0(1.65)	28.6(1.13)	50.0(1.97)	46.0(1.81)
38	1 1/2	-S-MJ38RT24	91.6(3.61)	26.2(1.03)	49.4(1.94)	33.7(1.33)	60.0(2.36)	55.0(2.17)

◆ 尺寸“E”为最小公称孔口,此孔口在管螺纹端、直螺纹端可能会更大。

▶ 卡套阳螺纹接头

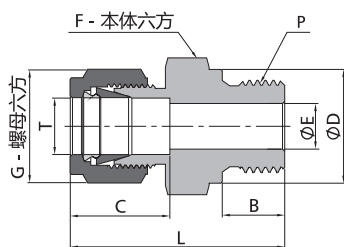

公制 Tube 管			ISO 平行螺纹 (BS)						
T-Tube 管外径 (mm)	P-BS 尺寸	基本订购号	尺寸, mm (in.)						
			L	B	C	E*	G	F	D
2	1/8	-S-MJ2BS2	30.0(1.18)	7.1(0.28)	12.9(0.51)	1.7(0.07)	12.0(0.47)	14.0(0.55)	13.7(0.54)
3	1/8	-S-MJ3BS2	30.0(1.18)	7.1(0.28)	12.9(0.51)	2.4(0.09)	12.0(0.47)	14.0(0.55)	13.7(0.54)
3	1/4	-S-MJ3BS4	35.3(1.39)	11.2(0.44)	12.9(0.51)	2.4(0.09)	12.0(0.47)	19.0(0.75)	18.0(0.71)
4	1/8	-S-MJ4BS2	30.7(1.21)	7.1(0.28)	13.7(0.54)	2.4(0.09)	12.0(0.47)	14.0(0.55)	13.7(0.54)
4	1/4	-S-MJ4BS4	36.0(1.42)	11.2(0.44)	13.7(0.54)	2.4(0.09)	12.0(0.47)	19.0(0.75)	18.0(0.71)
6	1/8	-S-MJ6BS2	32.3(1.27)	7.1(0.28)	15.3(0.60)	4.0(0.16)	14.0(0.55)	14.0(0.55)	13.7(0.54)
6	1/4	-S-MJ6BS4	37.6(1.48)	11.2(0.44)	15.3(0.60)	4.8(0.19)	14.0(0.55)	19.0(0.75)	18.0(0.71)
6	3/8	-S-MJ6BS6	38.9(1.53)	11.2(0.44)	15.3(0.60)	4.8(0.19)	14.0(0.55)	22.0(0.87)	21.6(0.85)
6	1/2	-S-MJ6BS8	44.7(1.76)	14.2(0.56)	15.3(0.60)	4.8(0.19)	14.0(0.55)	27.0(1.06)	25.9(1.02)
8	1/8	-S-MJ8BS2	33.2(1.31)	7.1(0.28)	16.2(0.64)	4.0(0.16)	16.0(0.63)	15.0(0.59)	13.7(0.54)
8	1/4	-S-MJ8BS4	38.5(1.52)	11.2(0.44)	16.2(0.64)	6.4(0.25)	16.0(0.63)	19.0(0.75)	18.0(0.71)
8	3/8	-S-MJ8BS6	39.8(1.57)	11.2(0.44)	16.2(0.64)	6.4(0.25)	16.0(0.63)	22.0(0.87)	21.6(0.85)
8	1/2	-S-MJ8BS8	45.6(1.80)	14.2(0.56)	16.2(0.64)	6.4(0.25)	16.0(0.63)	27.0(1.06)	25.9(1.02)
8	3/4	-S-MJ8BS12	49.5(1.95)	15.7(0.62)	16.2(0.64)	6.4(0.25)	16.0(0.63)	35.0(1.38)	32.0(1.26)
10	1/4	-S-MJ10BS4	39.4(1.55)	11.2(0.44)	17.2(0.68)	5.9(0.23)	19.0(0.75)	19.0(0.75)	18.0(0.71)
10	3/8	-S-MJ10BS6	40.6(1.60)	11.2(0.44)	17.2(0.68)	7.9(0.31)	19.0(0.75)	22.0(0.87)	21.6(0.85)
10	1/2	-S-MJ10BS8	46.5(1.83)	14.2(0.56)	17.2(0.68)	7.9(0.31)	19.0(0.75)	27.0(1.06)	25.9(1.02)
12	1/4	-S-MJ12BS4	42.6(1.68)	11.2(0.44)	22.8(0.90)	5.9(0.23)	22.0(0.87)	22.0(0.87)	18.0(0.71)
12	3/8	-S-MJ12BS6	43.1(1.70)	11.2(0.44)	22.8(0.90)	7.9(0.31)	22.0(0.87)	22.0(0.87)	21.6(0.85)
12	1/2	-S-MJ12BS8	49.0(1.93)	14.2(0.56)	22.8(0.90)	9.5(0.37)	22.0(0.87)	27.0(1.06)	25.9(1.02)
12	3/4	-S-MJ12BS12	52.8(2.08)	15.7(0.62)	22.8(0.90)	9.5(0.37)	22.0(0.87)	35.0(1.38)	32.0(1.26)
14	1/4	-S-MJ14BS4	44.2(1.74)	11.2(0.44)	24.4(0.96)	6.4(0.25)	25.0(0.98)	24.0(0.94)	18.0(0.71)
14	3/8	-S-MJ14BS6	43.9(1.73)	11.2(0.44)	24.4(0.96)	7.9(0.31)	25.0(0.98)	24.0(0.94)	21.6(0.85)
14	1/2	-S-MJ14BS8	49.0(1.93)	14.2(0.56)	24.4(0.96)	11.1(0.44)	25.0(0.98)	27.0(1.06)	25.9(1.02)
14	3/4	-S-MJ14BS12	52.8(2.08)	15.7(0.62)	24.4(0.96)	11.1(0.44)	25.0(0.98)	35.0(1.38)	32.0(1.26)
15	3/8	-S-MJ15BS6	43.9(1.73)	11.2(0.44)	24.4(0.96)	7.9(0.31)	25.0(0.98)	24.0(0.94)	21.6(0.85)
15	1/2	-S-MJ15BS8	49.0(1.93)	14.2(0.56)	24.4(0.96)	11.9(0.47)	25.0(0.98)	27.0(1.06)	25.9(1.02)
15	3/4	-S-MJ15BS12	52.8(2.08)	15.7(0.62)	24.4(0.96)	11.9(0.47)	25.0(0.98)	35.0(1.38)	32.0(1.26)
16	3/8	-S-MJ16BS6	43.9(1.73)	11.2(0.44)	24.4(0.96)	7.9(0.31)	25.0(0.98)	24.0(0.94)	21.6(0.85)
16	1/2	-S-MJ16BS8	49.0(1.93)	14.2(0.56)	24.4(0.96)	11.9(0.47)	25.0(0.98)	27.0(1.06)	25.9(1.02)
16	3/4	-S-MJ16BS12	52.8(2.08)	15.7(0.62)	24.4(0.96)	12.7(0.5)	25.0(0.98)	35.0(1.38)	32.0(1.26)
18	1/2	-S-MJ18BS8	49.0(1.93)	14.2(0.56)	24.4(0.96)	11.9(0.47)	30.0(1.18)	27.0(1.06)	25.9(1.02)
18	3/4	-S-MJ18BS12	52.8(2.08)	15.7(0.62)	24.4(0.96)	15.1(0.59)	30.0(1.18)	35.0(1.38)	32.0(1.26)
20	1/2	-S-MJ20BS8	50.5(1.99)	14.2(0.56)	26.0(1.02)	11.9(0.47)	32.0(1.26)	30.0(1.18)	25.9(1.02)
20	3/4	-S-MJ20BS12	52.8(2.08)	15.7(0.62)	26.0(1.02)	15.9(0.63)	32.0(1.26)	35.0(1.38)	32.0(1.26)
22	3/4	-S-MJ22BS12	52.8(2.08)	15.7(0.62)	26.0(1.02)	15.9(0.63)	32.0(1.26)	35.0(1.38)	32.0(1.26)
22	1	-S-MJ22BS16	55.3(2.18)	18.3(0.72)	26.0(1.02)	18.3(0.72)	32.0(1.26)	41.0(1.61)	39.1(1.54)
25	3/4	-S-MJ25BS12	57.5(2.26)	15.7(0.62)	31.3(1.23)	15.9(0.63)	38.0(1.50)	35.0(1.38)	32.0(1.26)
25	1	-S-MJ25BS16	60.1(2.37)	18.3(0.72)	31.3(1.23)	19.8(0.78)	38.0(1.50)	41.0(1.61)	39.1(1.54)
28	1	-S-MJ28BS16	70.1(2.76)	18.3(0.72)	36.6(1.44)	19.8(0.78)	46.0(1.81)	41.0(1.61)	39.1(1.54)
28	1 1/4	-S-MJ28BS20	73.9(2.91)	19.8(0.78)	36.6(1.44)	21.8(0.86)	46.0(1.81)	50.0(1.97)	49.0(1.93)
30	1 1/4	-S-MJ30BS20	76.5(3.01)	19.8(0.78)	39.6(1.56)	26.2(1.03)	50.0(1.97)	50.0(1.97)	49.0(1.93)
32	1 1/4	-S-MJ32BS20	79.2(3.12)	19.8(0.78)	42.0(1.65)	28.6(1.13)	50.0(1.97)	50.0(1.97)	49.0(1.93)
38	1 1/2	-S-MJ38BS24	90.8(3.57)	20.6(0.81)	49.4(1.94)	31.8(1.25)	60.0(2.36)	55.0(2.17)	54.7(2.15)

◆ 尺寸“E”为最小公称孔口,此孔口在管螺纹端、直螺纹端可能会更大。

▶ 卡套阳螺纹接头

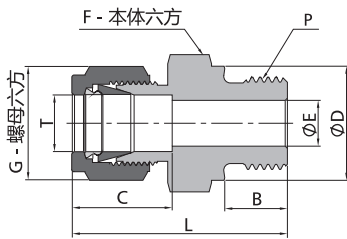

公制 Tube 管			ISO 平行螺纹 (BR)						
T-Tube 管外径 (mm)	P-BR 尺寸	基本 订购号	尺寸, mm (in.)						
			L	B	C	E *	G	F	D
3	1/8	-S-MJ3BR2	30.0(1.18)	7.1(0.28)	12.9(0.51)	2.4(0.09)	12.0(0.47)	14.0(0.55)	13.8(0.54)
3	1/4	-S-MJ3BR4	35.3(1.39)	11.2(0.44)	12.9(0.51)	2.4(0.09)	12.0(0.47)	19.0(0.75)	18.0(0.71)
4	1/8	-S-MJ4BR2	30.7(1.21)	7.1(0.28)	13.7(0.54)	2.4(0.09)	12.0(0.47)	14.0(0.55)	13.8(0.54)
6	1/8	-S-MJ6BR2	32.3(1.27)	7.1(0.28)	15.3(0.60)	4.0(0.16)	14.0(0.55)	14.0(0.55)	13.8(0.54)
6	1/4	-S-MJ6BR4	37.6(1.48)	11.2(0.44)	15.3(0.60)	4.8(0.19)	14.0(0.55)	19.0(0.75)	18.0(0.71)
6	3/8	-S-MJ6BR6	38.9(1.53)	11.2(0.44)	15.3(0.60)	4.8(0.19)	14.0(0.55)	22.0(0.87)	21.8(0.86)
6	1/2	-S-MJ6BR8	44.7(1.76)	14.2(0.56)	15.3(0.60)	4.8(0.19)	14.0(0.55)	27.0(1.06)	26.0(1.02)
8	1/8	-S-MJ8BR2	33.3(1.31)	7.1(0.28)	16.2(0.64)	4.0(0.16)	16.0(0.63)	15.0(0.59)	13.8(0.54)
8	1/4	-S-MJ8BR4	38.5(1.52)	11.2(0.44)	16.2(0.64)	5.9(0.23)	16.0(0.63)	19.0(0.75)	18.0(0.71)
8	3/8	-S-MJ8BR6	39.8(1.57)	11.2(0.44)	16.2(0.64)	6.4(0.25)	16.0(0.63)	22.0(0.87)	21.8(0.86)
8	1/2	-S-MJ8BR8	45.6(1.80)	14.2(0.56)	16.2(0.64)	6.4(0.25)	16.0(0.63)	27.0(1.06)	26.0(1.02)
10	1/4	-S-MJ10BR4	39.4(1.55)	11.2(0.44)	17.2(0.68)	5.9(0.23)	19.0(0.75)	19.0(0.75)	18.0(0.71)
10	3/8	-S-MJ10BR6	42.8(1.69)	11.2(0.44)	17.2(0.68)	7.9(0.31)	19.0(0.75)	22.0(0.87)	21.8(0.86)
10	1/2	-S-MJ10BR8	46.5(1.83)	14.2(0.56)	17.2(0.68)	7.9(0.31)	19.0(0.75)	27.0(1.06)	26.0(1.02)
12	1/4	-S-MJ12BR4	42.6(1.68)	11.2(0.44)	22.8(0.90)	5.9(0.23)	22.0(0.87)	22.0(0.87)	18.0(0.71)
12	3/8	-S-MJ12BR6	43.1(1.70)	11.2(0.44)	22.8(0.90)	7.9(0.31)	22.0(0.87)	22.0(0.87)	21.8(0.86)
12	1/2	-S-MJ12BR8	49.0(1.93)	14.2(0.56)	22.8(0.90)	9.5(0.37)	22.0(0.87)	27.0(1.06)	26.0(1.02)
12	3/4	-S-MJ12BR12	52.8(2.08)	15.7(0.62)	22.8(0.90)	9.5(0.37)	22.0(0.87)	35.0(1.38)	32.0(1.26)
15	1/2	-S-MJ15BR8	47.5(1.87)	14.2(0.56)	24.4(0.96)	11.9(0.47)	25.0(0.98)	27.0(1.06)	26.0(1.02)
16	3/8	-S-MJ16BR6	43.9(1.73)	11.2(0.44)	24.4(0.96)	7.9(0.31)	25.0(0.98)	24.0(0.94)	21.8(0.86)
16	1/2	-S-MJ16BR8	49.0(1.93)	14.2(0.56)	24.4(0.96)	11.9(0.47)	25.0(0.98)	27.0(1.06)	26.0(1.02)
18	1/2	-S-MJ18BR8	49.0(1.93)	14.2(0.56)	24.4(0.96)	11.9(0.47)	30.0(1.18)	27.0(1.06)	26.0(1.02)
18	3/4	-S-MJ18BR12	52.8(2.08)	15.7(0.62)	24.4(0.96)	15.1(0.59)	30.0(1.18)	35.0(1.38)	32.0(1.26)
20	1/2	-S-MJ20BR8	50.5(1.99)	14.2(0.56)	26.0(1.02)	11.9(0.47)	32.0(1.26)	30.0(1.18)	26.0(1.02)
20	3/4	-S-MJ20BR12	52.8(2.08)	15.7(0.62)	26.0(1.02)	15.9(0.63)	32.0(1.26)	35.0(1.38)	32.0(1.26)
22	3/4	-S-MJ22BR12	52.8(2.08)	15.7(0.62)	26.0(1.02)	15.9(0.63)	32.0(1.26)	35.0(1.38)	32.0(1.26)
22	1	-S-MJ22BR16	55.3(2.18)	18.3(0.72)	26.0(1.02)	18.3(0.72)	32.0(1.26)	41.0(1.61)	39.0(1.54)
25	3/4	-S-MJ25BR12	57.5(2.26)	15.7(0.62)	31.3(1.23)	15.9(0.63)	38.0(1.50)	35.0(1.38)	32.0(1.26)
25	1	-S-MJ25BR16	60.1(2.37)	18.3(0.72)	31.3(1.23)	19.8(0.78)	38.0(1.50)	41.0(1.61)	39.0(1.54)
28	1	-S-MJ28BR16	70.1(2.76)	18.3(0.72)	36.6(1.44)	19.8(0.78)	46.0(1.81)	41.0(1.61)	39.0(1.54)
28	1 1/4	-S-MJ28BR20	73.9(2.91)	19.8(0.78)	36.6(1.44)	21.8(0.86)	46.0(1.81)	50.0(1.97)	49.0(1.93)
30	1 1/4	-S-MJ30BR20	76.5(3.01)	19.8(0.78)	39.6(1.56)	26.2(1.03)	50.0(1.97)	50.0(1.97)	49.0(1.93)
32	1 1/4	-S-MJ32BR20	78.9(3.11)	19.8(0.78)	42.0(1.65)	28.6(1.13)	50.0(1.97)	50.0(1.97)	49.0(1.93)
38	1 1/2	-S-MJ38BR24	89.3(3.52)	20.6(0.81)	49.4(1.94)	31.8(1.25)	60.0(2.36)	55.0(2.17)	54.7(2.15)

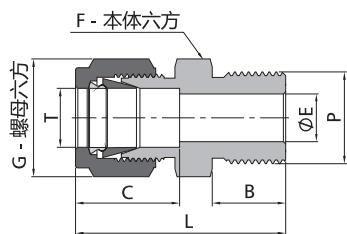

公制 Tube 管			ISO 平行螺纹 (BP)					
T-Tube 管外径 (mm)	P-BP 尺寸	基本 订购号	尺寸, mm (in.)					
			L	B	C	E *	G	F
6	1/4	-S-MJ6BP4	36.9(1.45)	12.9(0.51)	15.3(0.60)	4.8(0.19)	14.0(0.55)	14.0(0.55)
6	3/8	-S-MJ6BP6	39.5(1.56)	14.2(0.56)	15.3(0.60)	4.8(0.19)	14.0(0.55)	18.0(0.71)
8	1/8	-S-MJ8BP2	33.9(1.33)	9.8(0.39)	16.2(0.64)	4.0(0.16)	16.0(0.63)	14.0(0.55)
8	1/4	-S-MJ8BP4	37.0(1.46)	12.9(0.51)	16.2(0.64)	6.4(0.25)	16.0(0.63)	14.0(0.55)
8	3/8	-S-MJ8BP6	39.3(1.55)	14.2(0.56)	16.2(0.64)	6.4(0.25)	16.0(0.63)	18.0(0.71)
8	1/2	-S-MJ8BP8	45.4(1.79)	18.8(0.74)	16.2(0.64)	6.4(0.25)	16.0(0.63)	22.0(0.87)
10	1/4	-S-MJ10BP4	39.5(1.56)	12.9(0.51)	17.2(0.68)	5.9(0.23)	19.0(0.75)	18.0(0.71)
10	1/2	-S-MJ10BP8	46.3(1.82)	18.8(0.74)	17.2(0.68)	7.9(0.31)	19.0(0.75)	22.0(0.87)
12	3/8	-S-MJ12BP6	44.2(1.74)	14.2(0.56)	22.8(0.90)	7.9(0.31)	22.0(0.87)	22.0(0.87)
12	1/2	-S-MJ12BP8	52.1(2.05)	18.8(0.74)	22.8(0.90)	9.5(0.37)	22.0(0.87)	22.0(0.87)
14	1/4	-S-MJ14BP4	42.9(1.69)	12.9(0.51)	24.4(0.96)	5.9(0.23)	25.0(0.98)	24.0(0.94)
16	3/8	-S-MJ16BP6	43.4(1.71)	14.2(0.56)	24.4(0.96)	7.9(0.31)	25.0(0.98)	24.0(0.94)
16	1/2	-S-MJ16BP8	47.9(1.89)	18.8(0.74)	24.4(0.96)	9.5(0.37)	25.0(0.98)	24.0(0.94)
18	1/2	-S-MJ18BP8	49.8(1.96)	18.8(0.74)	24.4(0.96)	9.5(0.37)	30.0(1.18)	27.0(1.06)

◆ 尺寸“E”为最小公称孔口,此孔口在管螺纹端、直螺纹端可能会更大。

▶ 卡套阳螺纹接头

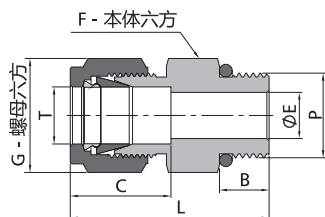

◆ 转接至 SAE J1926-1、ISO 11926-1 和 MS 16142 直螺纹凸台。

公制 Tube 管				SAE/MS 直螺纹 (ST)					
T-Tube 管外径 (mm)	P-SAE 名义 尺寸	P-SAE/MS 螺纹 规格	基本 订购号	尺寸, mm (in.)					
				L	B	C	E*	G	F
6	6	9/16-18	-S-MJ6ST9	35.6(1.40)	9.9(0.39)	15.3(0.60)	4.8(0.19)	14.0(0.55)	18.0(0.71)
10	6	9/16-18	-S-MJ10ST9	37.3(1.47)	9.9(0.39)	17.2(0.68)	7.1(0.28)	19.0(0.75)	18.0(0.71)
10	8	3/4-16	-S-MJ10ST12	39.4(1.55)	11.2(0.44)	17.2(0.68)	7.9(0.31)	19.0(0.75)	22.0(0.87)
12	4	7/16-20	-S-MJ12ST7	40.6(1.60)	9.1(0.36)	22.8(0.90)	5.2(0.20)	22.0(0.87)	22.0(0.87)
12	6	9/16-18	-S-MJ12ST9	39.9(1.57)	9.9(0.39)	22.8(0.90)	7.1(0.28)	22.0(0.87)	22.0(0.87)

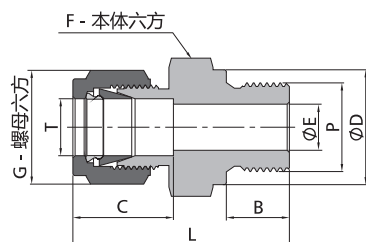

公制 Tube 管				公制螺纹 (MR)						
T-Tube 管外径 (mm)	P-公制 螺纹尺寸	基本订购号	尺寸, mm (in.)							
			L	B	C	E*	G	F	D	
6	M8 x 1	-S-MJ6MR8	33.3(1.31)	8.0(0.31)	15.3(0.60)	3.0(0.12)	14.0(0.55)	14.0(0.55)	12.0(0.47)	
6	M10 x 1	-S-MJ6MR10	33.3(1.31)	8.0(0.31)	15.3(0.60)	4.0(0.16)	14.0(0.55)	14.0(0.55)	14.0(0.55)	
6	M12 x 1.5	-S-MJ6MR12	38.2(1.50)	12.0(0.47)	15.3(0.60)	4.8(0.19)	14.0(0.55)	18.0(0.71)	17.0(0.67)	
6	M14 x 1.5	-S-MJ6MR14	39.7(1.56)	12.0(0.47)	15.3(0.60)	4.8(0.19)	14.0(0.55)	22.0(0.87)	19.0(0.75)	
8	M8 x 1	-S-MJ8MR8	34.1(1.34)	8.0(0.31)	16.2(0.64)	3.0(0.12)	16.0(0.63)	14.0(0.55)	12.0(0.47)	
8	M10 x 1	-S-MJ8MR10	34.1(1.34)	8.0(0.31)	16.2(0.64)	5.0(0.20)	16.0(0.63)	14.0(0.55)	14.0(0.55)	
8	M12 x 1.5	-S-MJ8MR12	40.4(1.59)	12.0(0.47)	16.2(0.64)	6.0(0.24)	16.0(0.63)	18.0(0.71)	17.0(0.67)	
8	M14 x 1.5	-S-MJ8MR14	40.4(1.59)	12.0(0.47)	16.2(0.64)	6.4(0.25)	16.0(0.63)	19.0(0.75)	19.0(0.75)	
10	M12 x 1.5	-S-MJ10MR12	40.7(1.60)	12.0(0.47)	17.2(0.68)	6.0(0.24)	19.0(0.75)	18.0(0.71)	17.0(0.67)	
10	M14 x 1.5	-S-MJ10MR14	39.5(1.56)	12.0(0.47)	17.2(0.68)	7.9(0.31)	19.0(0.75)	19.0(0.75)	19.0(0.75)	
12	M16 x 1.5	-S-MJ12MR16	45.5(1.79)	12.0(0.47)	22.8(0.90)	9.0(0.35)	22.0(0.87)	22.0(0.87)	21.0(0.83)	
12	M20 x 1.5	-S-MJ12MR20	48.0(1.89)	14.0(0.55)	22.8(0.90)	9.5(0.37)	22.0(0.87)	25.0(0.98)	25.0(0.98)	
12	M22 x 1.5	-S-MJ12MR22	47.5(1.87)	14.0(0.55)	22.8(0.90)	9.5(0.37)	22.0(0.87)	27.0(1.06)	27.0(1.06)	
14	M14 x 1.5	-S-MJ14MR14	44.9(1.77)	12.0(0.47)	24.4(0.96)	8.0(0.31)	25.0(0.98)	24.0(0.94)	19.0(0.75)	
14	M20 x 1.5	-S-MJ14MR20	48.0(1.89)	14.0(0.55)	24.4(0.96)	11.1(0.44)	25.0(0.98)	27.0(1.06)	25.0(0.98)	
16	M20 x 1.5	-S-MJ16MR20	48.0(1.89)	14.0(0.55)	24.4(0.96)	12.0(0.47)	25.0(0.98)	25.0(0.98)	25.0(0.98)	
18	M20 x 1.5	-S-MJ18MR20	48.5(1.91)	14.0(0.55)	24.4(0.96)	12.0(0.47)	30.0(1.18)	27.0(1.06)	25.0(0.98)	
20	M20 x 1.5	-S-MJ20MR20	50.0(1.97)	14.0(0.55)	26.0(1.02)	12.0(0.47)	32.0(1.26)	30.0(1.18)	25.0(0.98)	
22	M24 x 1.5	-S-MJ22MR24	50.5(1.99)	14.0(0.55)	26.0(1.02)	15.0(0.59)	32.0(1.26)	30.0(1.18)	28.8(1.13)	
25	M27 x 2	-S-MJ25MR27	57.5(2.26)	16.0(0.63)	31.3(1.23)	16.8(0.66)	38.0(1.50)	35.0(1.38)	32.0(1.26)	

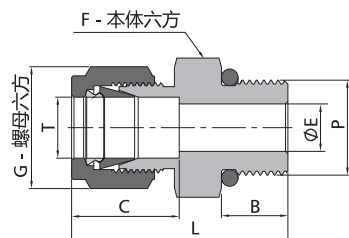

◆ 转接至 ISO 6149-1 直螺纹凸台。

公制 Tube 管				公制螺纹 (MO)					
T-Tube 管外径 (mm)	P-公制 螺纹尺寸	基本订购号	尺寸, mm (in.)						
			L	B	C	E*	G	F	
6	M14 x 1.5	-S-MJ6MO14	38.7(1.52)	11.0(0.43)	15.3(0.60)	4.8(0.19)	14.0(0.55)	19.0(0.75)	
10	M14 x 1.5	-S-MJ10MO14	40.0(1.57)	11.0(0.43)	17.2(0.68)	7.5(0.30)	19.0(0.75)	19.0(0.75)	
10	M20 x 1.5	-S-MJ10MO20	41.2(1.62)	14.0(0.55)	17.2(0.68)	7.9(0.31)	19.0(0.75)	27.0(1.06)	
12	M14 x 1.5	-S-MJ12MO14	40.2(1.58)	11.0(0.43)	22.8(0.90)	7.5(0.30)	22.0(0.87)	22.0(0.87)	
12	M20 x 1.5	-S-MJ12MO20	47.2(1.86)	14.0(0.55)	22.8(0.90)	9.5(0.37)	22.0(0.87)	27.0(1.06)	

◆ 尺寸"E"为最小公称孔口,此孔口在管螺纹端、直螺纹端可能会更大。

▶ 卡套阳螺纹接头

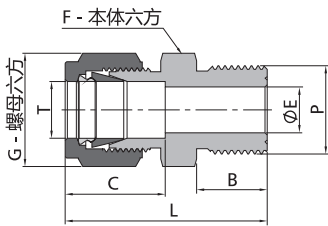

公制 Tube 管			公制螺纹 (MS)					
T-Tube 管外径 (mm)	P-公制 螺纹尺寸	基本订购号	尺寸, mm (in.)					
			L	B	C	E*	G	F
6	M6 x 1	-S-MJ6MS6	32.4(1.28)	8.0(0.31)	15.3(0.60)	2.0(0.08)	14.0(0.55)	14.0(0.55)
6	M8 x 1	-S-MJ6MS8	35.3(1.39)	9.0(0.35)	15.3(0.60)	3.0(0.12)	14.0(0.55)	14.0(0.55)
6	M10 x 1	-S-MJ6MS10	34.7(1.37)	11.0(0.43)	15.3(0.60)	4.7(0.19)	14.0(0.55)	14.0(0.55)
6	M12 x 1.5	-S-MJ6MS12	36.4(1.43)	12.0(0.47)	15.3(0.60)	4.8(0.19)	14.0(0.55)	14.0(0.55)
6	M14 x 1.5	-S-MJ6MS14	36.5(1.44)	13.0(0.51)	15.3(0.60)	4.8(0.19)	14.0(0.55)	16.0(0.63)
6	M16 x 1.5	-S-MJ6MS16	38.4(1.51)	14.0(0.55)	15.3(0.60)	4.8(0.19)	14.0(0.55)	18.0(0.71)
6	M18 x 1.5	-S-MJ6MS18	40.0(1.57)	15.0(0.59)	15.3(0.60)	4.8(0.19)	14.0(0.55)	19.0(0.75)
6	M20 x 1.5	-S-MJ6MS20	41.7(1.64)	16.0(0.63)	15.3(0.60)	4.8(0.19)	14.0(0.55)	22.0(0.87)
8	M8 x 1	-S-MJ8MS8	34.5(1.36)	9.0(0.35)	16.2(0.64)	3.0(0.12)	16.0(0.63)	14.0(0.55)
8	M10 x 1	-S-MJ8MS10	36.6(1.44)	11.0(0.43)	16.2(0.64)	4.7(0.19)	16.0(0.63)	14.0(0.55)
8	M12 x 1.5	-S-MJ8MS12	36.6(1.44)	12.0(0.47)	16.2(0.64)	6.0(0.24)	16.0(0.63)	14.0(0.55)
8	M14 x 1.5	-S-MJ8MS14	37.7(1.48)	13.0(0.51)	16.2(0.64)	6.4(0.25)	16.0(0.63)	16.0(0.63)
8	M20 x 1.5	-S-MJ8MS20	42.5(1.67)	16.0(0.63)	16.2(0.64)	6.4(0.25)	16.0(0.63)	22.0(0.87)
10	M12 x 1.5	-S-MJ10MS12	38.7(1.52)	12.0(0.47)	17.2(0.68)	6.0(0.24)	19.0(0.75)	18.0(0.71)
10	M14 x 1.5	-S-MJ10MS14	39.7(1.56)	13.0(0.51)	17.2(0.68)	7.2(0.28)	19.0(0.75)	18.0(0.71)
10	M20 x 1.5	-S-MJ10MS20	43.5(1.71)	16.0(0.63)	17.2(0.68)	7.9(0.31)	19.0(0.75)	22.0(0.87)
12	M12 x 1.5	-S-MJ12MS12	41.2(1.62)	12.0(0.47)	22.8(0.90)	6.0(0.24)	22.0(0.87)	22.0(0.87)
12	M16 x 1.5	-S-MJ12MS16	43.2(1.70)	14.0(0.55)	22.8(0.90)	8.4(0.33)	22.0(0.87)	22.0(0.87)
12	M18 x 1.5	-S-MJ12MS18	44.2(1.74)	15.0(0.59)	22.8(0.90)	9.5(0.37)	22.0(0.87)	22.0(0.87)
12	M20 x 1.5	-S-MJ12MS20	45.2(1.78)	16.0(0.63)	22.8(0.90)	9.5(0.37)	22.0(0.87)	22.0(0.87)
14	M14 x 1.5	-S-MJ14MS14	42.5(1.67)	13.0(0.51)	24.4(0.96)	7.2(0.28)	25.0(0.98)	24.0(0.94)
14	M16 x 1.5	-S-MJ14MS16	43.9(1.73)	14.0(0.55)	24.4(0.96)	8.4(0.33)	25.0(0.98)	24.0(0.94)
14	M20 x 1.5	-S-MJ14MS20	45.1(1.78)	16.0(0.63)	24.4(0.96)	10.8(0.43)	25.0(0.98)	24.0(0.94)
16	M20 x 1.5	-S-MJ16MS20	46.1(1.81)	16.0(0.63)	24.4(0.96)	10.8(0.43)	25.0(0.98)	24.0(0.94)
18	M20 x 1.5	-S-MJ18MS20	47.5(1.87)	16.0(0.63)	24.4(0.96)	10.8(0.43)	30.0(1.18)	27.0(1.06)
18	M22 x 1.5	-S-MJ18MS22	48.5(1.91)	17.0(0.67)	24.4(0.96)	12.0(0.47)	30.0(1.18)	27.0(1.06)
20	M20 x 1.5	-S-MJ20MS20	49.5(1.95)	16.0(0.63)	26.0(1.02)	10.8(0.43)	32.0(1.26)	30.0(1.18)
22	M24 x 1.5	-S-MJ22MS24	50.5(1.99)	17.0(0.67)	26.0(1.02)	14.4(0.57)	32.0(1.26)	30.0(1.18)
25	M27 x 2	-S-MJ25MS27	57.0(2.24)	18.0(0.71)	31.3(1.23)	16.1(0.63)	38.0(1.50)	35.0(1.38)

◆ 尺寸"E"为最小公称孔口,此孔口在管螺纹端、直螺纹端可能会更大。

▶ 卡套阳螺纹穿板接头

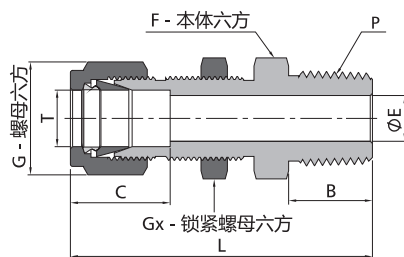

英制 Tube管										NPT 螺纹	
T-Tube 管外径 (in.)	P-NPT 尺寸	基本 订购号	尺寸, in. (mm)							面板孔 尺寸 in. (mm)	最大面板 厚度 in. (mm)
			L	B	C	E*	G	F	Gx		
1/16	1/16	-S-BFJ1N1	1.19(30.2)	0.38(9.7)	0.34(8.6)	0.05(1.3)	0.31(7.9)	0.31(7.9)	0.31(7.9)	0.20(5.2)	0.25(6.4)
1/16	1/8	-S-BFJ1N2	1.27(32.3)	0.38(9.7)	0.34(8.6)	0.05(1.3)	0.31(7.9)	0.44(11.1)	0.31(7.9)	0.20(5.2)	0.25(6.4)
1/8	1/8	-S-BFJ2N2	1.83(46.5)	0.38(9.7)	0.50(12.7)	0.09(2.3)	0.44(11.1)	0.50(12.7)	0.50(12.7)	0.33(8.3)	0.50(12.7)
3/16	1/8	-S-BFJ3N2	1.89(48.0)	0.38(9.7)	0.54(13.7)	0.12(3.0)	0.50(12.7)	0.56(14.3)	0.56(14.3)	0.39(9.9)	0.50(12.7)
1/4	1/8	-S-BFJ4N2	1.95(49.5)	0.38(9.7)	0.60(15.2)	0.19(4.8)	0.56(14.3)	0.63(15.9)	0.63(15.9)	0.45(11.5)	0.40(10.2)
1/4	1/4	-S-BFJ4N4	2.13(54.1)	0.56(14.2)	0.60(15.2)	0.19(4.8)	0.56(14.3)	0.63(15.9)	0.63(15.9)	0.45(11.5)	0.40(10.2)
1/4	3/8	-S-BFJ4N6	2.16(54.9)	0.56(14.2)	0.60(15.2)	0.19(4.8)	0.56(14.3)	0.69(17.5)	0.63(15.9)	0.45(11.5)	0.40(10.2)
1/4	1/2	-S-BFJ4N8	2.37(60.3)	0.75(19.1)	0.60(15.2)	0.19(4.8)	0.56(14.3)	0.87(22.2)	0.63(15.9)	0.45(11.5)	0.40(10.2)
5/16	1/8	-S-BFJ5N2	2.08(52.8)	0.38(9.7)	0.64(16.3)	0.19(4.8)	0.63(15.9)	0.69(17.5)	0.69(17.5)	0.52(13.1)	0.44(11.2)
5/16	1/4	-S-BFJ5N4	2.27(57.7)	0.56(14.2)	0.64(16.3)	0.25(6.4)	0.63(15.9)	0.69(17.5)	0.69(17.5)	0.52(13.1)	0.44(11.2)
3/8	1/8	-S-BFJ6N2	2.08(52.9)	0.38(9.7)	0.66(16.8)	0.19(4.8)	0.69(17.5)	0.75(19.1)	0.75(19.1)	0.58(14.7)	0.44(11.2)
3/8	1/4	-S-BFJ6N4	2.26(57.4)	0.56(14.2)	0.66(16.8)	0.28(7.1)	0.69(17.5)	0.75(19.1)	0.75(19.1)	0.58(14.7)	0.44(11.2)
3/8	3/8	-S-BFJ6N6	2.26(57.4)	0.56(14.2)	0.66(16.8)	0.28(7.1)	0.69(17.5)	0.75(19.1)	0.75(19.1)	0.58(14.7)	0.44(11.2)
3/8	1/2	-S-BFJ6N8	2.51(63.8)	0.75(19.1)	0.66(16.8)	0.28(7.1)	0.69(17.5)	0.87(22.2)	0.87(22.2)	0.58(14.7)	0.44(11.2)
1/2	1/8	-S-BFJ8N2	2.31(58.7)	0.38(9.7)	0.90(22.9)	0.19(4.8)	0.87(22.2)	0.94(23.8)	0.94(23.8)	0.76(19.4)	0.50(12.7)
1/2	1/4	-S-BFJ8N4	2.23(56.6)	0.56(14.2)	0.90(22.9)	0.28(7.1)	0.87(22.2)	0.94(23.8)	0.94(23.8)	0.76(19.4)	0.50(12.7)
1/2	3/8	-S-BFJ8N6	2.49(63.2)	0.56(14.2)	0.90(22.9)	0.38(9.7)	0.87(22.2)	0.94(23.8)	0.94(23.8)	0.76(19.4)	0.50(12.7)
1/2	1/2	-S-BFJ8N8	2.71(68.8)	0.75(19.1)	0.90(22.9)	0.41(10.4)	0.87(22.2)	0.94(23.8)	0.94(23.8)	0.76(19.4)	0.50(12.7)
5/8	3/8	-S-BFJ10N6	2.63(66.7)	0.56(14.2)	0.96(24.4)	0.38(9.7)	1.00(25.4)	1.06(27.0)	1.06(27.0)	0.89(22.6)	0.59(15.1)
5/8	1/2	-S-BFJ10N8	2.81(71.5)	0.75(19.1)	0.96(24.4)	0.47(11.9)	1.00(25.4)	1.06(27.0)	1.06(27.0)	0.89(22.6)	0.59(15.1)
3/4	1/2	-S-BFJ12N8	3.00(76.2)	0.75(19.1)	0.96(24.4)	0.47(11.9)	1.13(28.6)	1.19(30.2)	1.19(30.2)	1.02(25.8)	0.66(16.8)
3/4	3/4	-S-BFJ12N12	3.00(76.2)	0.75(19.1)	0.96(24.4)	0.62(15.7)	1.13(28.6)	1.19(30.2)	1.19(30.2)	1.02(25.8)	0.66(16.8)
7/8	3/4	-S-BFJ14N12	3.31(84.1)	0.75(19.1)	1.02(25.9)	0.62(15.7)	1.25(31.8)	1.31(33.3)	1.31(33.3)	1.14(29.0)	0.75(19.1)
1	3/4	-S-BFJ16N12	3.48(88.4)	0.75(19.1)	1.23(31.2)	0.62(15.7)	1.50(38.1)	1.63(41.3)	1.63(41.3)	1.33(33.7)	0.75(19.1)
1	1	-S-BFJ16N16	3.67(93.2)	0.94(23.9)	1.23(31.2)	0.88(22.4)	1.50(38.1)	1.63(41.3)	1.63(41.3)	1.33(33.7)	0.75(19.1)

公制 Tube管										NPT 螺纹	
T-Tube 管外径 (mm)	P-NPT 尺寸	基本 订购号	尺寸, mm (in.)							面板孔 尺寸 mm (in.)	最大面板 厚度 mm (in.)
			L	B	C	E*	G	F	Gx		
6	1/8	-S-BMJ6N2	49.6(1.95)	9.7(0.38)	15.3(0.60)	4.8(0.19)	14.0(0.55)	16.0(0.63)	16.0(0.63)	11.5(0.45)	10.2(0.40)
6	1/4	-S-BMJ6N4	53.6(2.11)	14.2(0.56)	15.3(0.60)	4.8(0.19)	14.0(0.55)	16.0(0.63)	16.0(0.63)	11.5(0.45)	10.2(0.40)
8	1/8	-S-BMJ8N2	52.3(2.06)	9.7(0.38)	16.2(0.64)	4.8(0.19)	16.0(0.63)	18.0(0.71)	18.0(0.71)	13.1(0.52)	11.2(0.44)
8	1/4	-S-BMJ8N4	56.6(2.23)	14.2(0.56)	16.2(0.64)	6.4(0.25)	16.0(0.63)	18.0(0.71)	18.0(0.71)	13.1(0.52)	11.2(0.44)
10	1/4	-S-BMJ10N4	58.4(2.30)	14.2(0.56)	17.2(0.68)	7.1(0.28)	19.0(0.75)	22.0(0.87)	22.0(0.87)	16.3(0.64)	11.2(0.44)
10	3/8	-S-BMJ10N6	58.4(2.30)	14.2(0.56)	17.2(0.68)	7.9(0.31)	19.0(0.75)	22.0(0.87)	22.0(0.87)	16.3(0.64)	11.2(0.44)
10	1/2	-S-BMJ10N8	63.1(2.48)	19.1(0.75)	17.2(0.68)	7.9(0.31)	19.0(0.75)	22.0(0.87)	22.0(0.87)	16.3(0.64)	11.2(0.44)
12	1/4	-S-BMJ12N4	63.9(2.52)	14.2(0.56)	22.8(0.90)	7.1(0.28)	22.0(0.87)	24.0(0.94)	24.0(0.94)	19.5(0.77)	12.7(0.50)
12	3/8	-S-BMJ12N6	63.9(2.52)	14.2(0.56)	22.8(0.90)	9.5(0.37)	22.0(0.87)	24.0(0.94)	24.0(0.94)	19.5(0.77)	12.7(0.50)
12	1/2	-S-BMJ12N8	68.8(2.71)	19.1(0.75)	22.8(0.90)	9.5(0.37)	22.0(0.87)	24.0(0.94)	24.0(0.94)	19.5(0.77)	12.7(0.50)

◆ 尺寸“E”为最小公称孔口,此孔口在管螺纹端、直螺纹端可能会更大。

▶ 卡套阳螺纹穿板接头

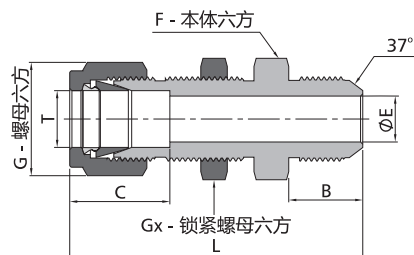

◆ 尺寸“E”为最小公称孔口,此孔口在管螺纹端、直螺纹端可能会更大。

英制 Tube 管			37° 扩口 (AN)								
T-Tube 管外径 (in.)	AN Tube 管扩口 尺寸	基本 订购号	尺寸, in. (mm)							面板孔 尺寸 in. (mm)	最大面板 厚度 in. (mm)
			L	B	C	E*	G	F	Gx		
1/8	1/8	-S-BFJ2AN2	1.91(48.5)	0.45(11.4)	0.50(12.7)	0.06(1.5)	0.44(11.1)	0.50(12.7)	0.50(12.7)	0.33(8.3)	0.50(12.7)
1/8	1/4	-S-BFJ2AN4	2.04(51.8)	0.55(14.0)	0.50(12.7)	0.09(2.3)	0.44(11.1)	0.63(15.9)	0.50(12.7)	0.33(8.3)	0.50(12.7)
3/16	3/16	-S-BFJ3AN3	1.98(50.3)	0.48(12.2)	0.54(13.7)	0.12(3.0)	0.50(12.7)	0.56(14.3)	0.56(14.3)	0.39(9.9)	0.50(12.7)
1/4	1/4	-S-BFJ4AN4	2.12(53.8)	0.55(14.0)	0.60(15.2)	0.17(4.3)	0.56(14.3)	0.63(15.9)	0.63(15.9)	0.45(11.5)	0.40(10.2)
5/16	5/16	-S-BFJ5AN5	2.21(56.1)	0.55(14.0)	0.64(16.2)	0.23(5.8)	0.63(15.9)	0.69(17.5)	0.69(17.5)	0.52(13.1)	0.56(14.3)
3/8	1/4	-S-BFJ6AN4	2.25(57.2)	0.55(14.0)	0.66(16.8)	0.17(4.3)	0.69(17.5)	0.75(19.1)	0.75(19.1)	0.58(14.7)	0.44(11.2)
3/8	3/8	-S-BFJ6AN6	2.25(57.2)	0.56(14.2)	0.66(16.8)	0.28(7.1)	0.69(17.5)	0.75(19.1)	0.75(19.1)	0.58(14.7)	0.44(11.2)
1/2	1/2	-S-BFJ8AN8	2.59(65.8)	0.66(16.8)	0.90(22.8)	0.39(9.9)	0.87(22.2)	0.94(23.8)	0.94(23.8)	0.76(19.4)	0.50(12.7)
5/8	5/8	-S-BFJ10AN10	2.74(69.6)	0.76(19.3)	0.96(24.4)	0.48(12.3)	1.00(25.4)	1.06(27.0)	1.06(27.0)	0.89(22.6)	0.59(15.1)
3/4	3/4	-S-BFJ12AN12	3.11(79.0)	0.86(21.8)	0.96(24.4)	0.61(15.5)	1.13(28.6)	1.19(30.2)	1.19(30.2)	1.02(25.8)	0.66(16.8)
1	1	-S-BFJ16AN16	3.64(92.5)	0.91(23.1)	1.23(31.2)	0.84(21.3)	1.50(38.1)	1.63(41.3)	1.63(41.3)	1.33(33.7)	0.75(19.1)

▶ 卡套阳螺纹镗通接头

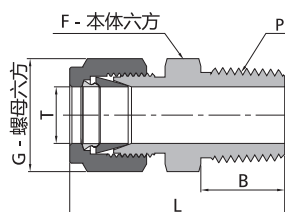

◆ 尺寸“T”为最小公称孔口,此孔口在管螺纹端、直螺纹端可能会更大。

英制 Tube 管			NPT 螺纹			
T-Tube 管外径 (in.)*	P-NPT 尺寸	基本 订购号	尺寸, in. (mm)			
			L	B	G	F
1/16	1/16	-S-TFJ1N1	0.94(23.9)	0.38(9.7)	0.31(7.9)	0.31(7.9)
1/16	1/8	-S-TFJ1N2	1.03(26.2)	0.38(9.7)	0.31(7.9)	0.44(11.1)
1/16	1/4	-S-TFJ1N4	1.22(31.0)	0.56(14.2)	0.31(7.9)	0.56(14.3)
1/8	1/16	-S-TFJ2N1	1.17(29.7)	0.38(9.7)	0.44(11.1)	0.44(11.1)
1/8	1/8	-S-TFJ2N2	1.20(30.5)	0.38(9.7)	0.44(11.1)	0.44(11.1)
1/8	1/4	-S-TFJ2N4	1.40(35.6)	0.56(14.2)	0.44(11.1)	0.56(14.3)
3/16	1/8	-S-TFJ3N2	1.23(31.2)	0.38(9.7)	0.50(12.7)	0.44(11.1)
3/16	1/4	-S-TFJ3N4	1.43(36.3)	0.56(14.2)	0.50(12.7)	0.56(14.3)
1/4	1/8	-S-TFJ4N2	1.29(32.8)	0.38(9.7)	0.56(14.3)	0.50(12.7)
1/4	1/4	-S-TFJ4N4	1.49(37.8)	0.56(14.2)	0.56(14.3)	0.56(14.3)
1/4	3/8	-S-TFJ4N6	1.51(38.4)	0.56(14.2)	0.56(14.3)	0.69(17.5)
1/4	1/2	-S-TFJ4N8	1.76(44.7)	0.75(19.1)	0.56(14.3)	0.87(22.2)
5/16	1/4	-S-TFJ5N4	1.52(38.6)	0.56(14.2)	0.63(15.9)	0.56(14.3)
3/8	1/4	-S-TFJ6N4	1.57(39.9)	0.56(14.2)	0.69(17.5)	0.63(15.9)
3/8	3/8	-S-TFJ6N6	1.57(39.9)	0.56(14.2)	0.69(17.5)	0.69(17.5)
3/8	1/2	-S-TFJ6N8	1.82(46.2)	0.75(19.1)	0.69(17.5)	0.87(22.2)
3/8	3/4	-S-TFJ6N12	1.88(47.8)	0.75(19.1)	0.69(17.5)	1.06(27.0)
1/2	1/2	-S-TFJ8N8	1.93(49.0)	0.75(19.1)	0.87(22.2)	0.87(22.2)
1/2	3/4	-S-TFJ8N12	1.99(50.5)	0.75(19.1)	0.87(22.2)	1.06(27.0)
5/8	3/4	-S-TFJ10N12	1.99(50.5)	0.75(19.1)	1.00(25.4)	1.06(27.0)
3/4	3/4	-S-TFJ12N12	1.99(50.5)	0.75(19.1)	1.13(28.6)	1.06(27.0)
1	1	-S-TFJ16N16	2.45(62.2)	0.94(23.9)	1.50(38.1)	1.37(34.9)

▶ 卡套阳螺纹锥通接头

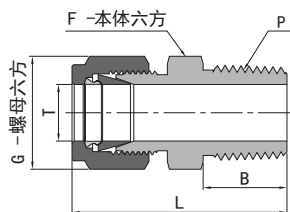

◆ 尺寸“T”为最小公称孔口,此孔口在管螺纹端、直螺纹端可能会更大。

公制 Tube管			NPT螺纹			
T-Tube 管外径 (mm)*	P-NPT 尺寸	基本 订购号	尺寸, mm (in.)			
			L	B	G	F
2	1/8	-S-TMJ2N2	30.5(1.20)	9.7(0.38)	12.0(0.47)	12.0(0.47)
3	1/8	-S-TMJ3N2	30.5(1.20)	9.7(0.38)	12.0(0.47)	12.0(0.47)
3	1/4	-S-TMJ3N4	35.6(1.40)	14.2(0.56)	12.0(0.47)	14.0(0.55)
4	1/8	-S-TMJ4N2	31.2(1.23)	9.7(0.38)	12.0(0.47)	12.0(0.47)
4	1/4	-S-TMJ4N4	36.3(1.43)	14.2(0.56)	12.0(0.47)	14.0(0.55)
6	1/8	-S-TMJ6N2	32.8(1.29)	9.7(0.38)	14.0(0.55)	14.0(0.55)
6	1/4	-S-TMJ6N4	37.9(1.49)	14.2(0.56)	14.0(0.55)	14.0(0.55)
6	3/8	-S-TMJ6N6	38.4(1.51)	14.2(0.56)	14.0(0.55)	18.0(0.71)
6	1/2	-S-TMJ6N8	44.7(1.76)	19.1(0.75)	14.0(0.55)	22.0(0.87)
8	1/4	-S-TMJ8N4	38.7(1.52)	14.2(0.56)	16.0(0.63)	15.0(0.59)
8	3/8	-S-TMJ8N6	39.3(1.55)	14.2(0.56)	16.0(0.63)	18.0(0.71)
8	1/2	-S-TMJ8N8	45.6(1.80)	19.1(0.75)	16.0(0.63)	22.0(0.87)
10	3/8	-S-TMJ10N6	40.9(1.61)	14.2(0.56)	19.0(0.75)	18.0(0.71)
10	1/2	-S-TMJ10N8	46.5(1.83)	19.1(0.75)	19.0(0.75)	22.0(0.87)
10	3/4	-S-TMJ10N12	48.0(1.89)	19.1(0.75)	19.0(0.75)	27.0(1.06)
10	1	-S-TMJ10N16	54.6(2.15)	23.9(0.94)	19.0(0.75)	35.0(1.38)
12	3/8	-S-TMJ12N6	43.4(1.71)	14.2(0.56)	22.0(0.87)	22.0(0.87)
12	1/2	-S-TMJ12N8	49.0(1.93)	19.1(0.75)	22.0(0.87)	22.0(0.87)
12	3/4	-S-TMJ12N12	50.5(1.99)	19.1(0.75)	22.0(0.87)	27.0(1.06)
14	1/2	-S-TMJ14N8	49.0(1.93)	19.1(0.75)	25.0(0.98)	24.0(0.94)
14	3/4	-S-TMJ14N12	50.5(1.99)	19.1(0.75)	25.0(0.98)	27.0(1.06)
15	3/4	-S-TMJ15N12	50.5(1.99)	19.1(0.75)	25.0(0.98)	27.0(1.06)
15	1	-S-TMJ15N16	57.1(2.25)	23.9(0.94)	25.0(0.98)	35.0(1.38)
18	3/4	-S-TMJ18N12	50.5(1.99)	19.1(0.75)	30.0(1.18)	27.0(1.06)
20	1	-S-TMJ20N16	57.1(2.25)	23.9(0.94)	32.0(1.26)	35.0(1.38)
22	1	-S-TMJ22N16	57.1(2.25)	23.9(0.94)	32.0(1.26)	35.0(1.38)

▶ 色谱分析接头

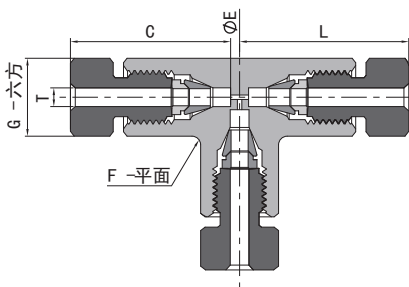
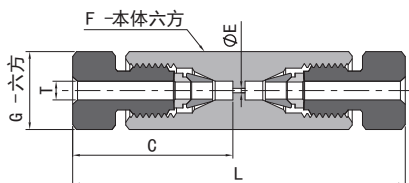

英制 Tube管		尺寸, in. (mm)					死区
T-Tube 管外径 (in.)	基本 订购号	L	C	E	G	F	
1/16	-S-NFJ1-LV	1.26(32.0)	0.61(15.5)	0.01(0.3)	0.25(6.4)	0.25(6.4)	$6.6 \times 10^{-5} \text{ cm}^3$

英制 Tube管		尺寸, in. (mm)					死区
T-Tube 管外径 (in.)	基本 订购号	L	C	E	G	F	
1/16	-T-NFJ1-LV	0.66(16.8)	0.61(15.5)	0.01(0.3)	0.25(6.4)	0.25(6.4)	$2.8 \times 10^{-4} \text{ cm}^3$

▶ 卡套阴螺纹接头

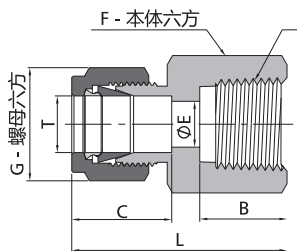

英制 Tube管			NPT 螺帽					
T-Tube 管外径 (in.)	P-NPT 尺寸	基本 订购号	尺寸, in. (mm)					
			L	B	C	E	G	F
1/16	1/16	-S-FJ1FN1	0.93(23.6)	0.39(9.9)	0.34(8.6)	0.05(1.3)	0.31(7.9)	0.44(11.1)
1/16	1/8	-S-FJ1FN2	0.96(24.4)	0.41(10.4)	0.34(8.6)	0.05(1.3)	0.31(7.9)	0.56(14.3)
1/8	1/8	-S-FJ2FN2	1.13(28.7)	0.41(10.4)	0.50(12.7)	0.09(2.3)	0.44(11.1)	0.56(14.3)
1/8	1/4	-S-FJ2FN4	1.32(33.5)	0.59(15.0)	0.50(12.7)	0.09(2.3)	0.44(11.1)	0.75(19.1)
3/16	1/8	-S-FJ3FN2	1.17(29.7)	0.41(10.4)	0.54(13.7)	0.12(3.0)	0.50(12.7)	0.56(14.3)
1/4	1/8	-S-FJ4FN2	1.23(31.2)	0.41(10.4)	0.60(15.2)	0.19(4.8)	0.56(14.3)	0.56(14.3)
1/4	1/4	-S-FJ4FN4	1.41(35.8)	0.59(15.0)	0.60(15.2)	0.19(4.8)	0.56(14.3)	0.75(19.1)
1/4	3/8	-S-FJ4FN6	1.48(37.6)	0.59(15.0)	0.60(15.2)	0.19(4.8)	0.56(14.3)	0.87(22.2)
1/4	1/2	-S-FJ4FN8	1.67(42.4)	0.78(19.8)	0.60(15.2)	16.3(4.8)	0.56(14.3)	1.06(27.0)
5/16	1/8	-S-FJ5FN2	1.26(32.0)	0.41(10.4)	0.64(16.3)	16.3(6.4)	0.63(15.9)	0.56(14.3)
5/16	1/4	-S-FJ5FN4	1.45(36.8)	0.59(15.0)	0.64(16.3)	0.25(6.4)	0.63(15.9)	0.75(19.1)
3/8	1/8	-S-FJ6FN2	1.29(32.8)	0.41(10.4)	0.66(16.8)	0.28(7.1)	0.69(17.5)	0.63(15.9)
3/8	1/4	-S-FJ6FN4	1.48(37.6)	0.59(15.0)	0.66(16.8)	0.28(7.1)	0.69(17.5)	0.75(19.1)
3/8	3/8	-S-FJ6FN6	1.54(39.1)	0.59(15.0)	0.66(16.8)	0.28(7.1)	0.69(17.5)	0.88(22.2)
3/8	1/2	-S-FJ6FN8	1.73(43.9)	0.78(19.8)	0.66(16.8)	0.28(7.1)	0.69(17.5)	1.06(27.0)
3/8	3/4	-S-FJ6FN12	1.88(47.8)	0.81(20.6)	0.66(16.8)	0.28(7.1)	0.69(17.5)	1.31(33.3)
1/2	1/4	-S-FJ8FN4	1.59(40.4)	0.59(15.0)	0.90(22.9)	0.41(10.4)	0.87(22.2)	0.81(20.6)
1/2	3/8	-S-FJ8FN6	1.65(41.9)	0.59(15.0)	0.90(22.9)	0.41(10.4)	0.87(22.2)	0.87(22.2)
1/2	1/2	-S-FJ8FN8	1.84(46.7)	0.78(19.8)	0.90(22.9)	0.41(10.4)	0.87(22.2)	1.06(27.0)
1/2	3/4	-S-FJ8FN12	1.90(48.3)	0.81(20.6)	0.90(22.9)	0.41(10.4)	0.87(22.2)	1.31(33.3)
5/8	3/8	-S-FJ10FN6	1.65(41.9)	0.59(15.0)	0.96(24.4)	0.50(12.7)	1.00(25.4)	0.94(23.8)
5/8	1/2	-S-FJ10FN8	1.84(46.7)	0.78(19.8)	0.96(24.4)	0.50(12.7)	1.00(25.4)	1.06(27.0)
3/4	1/2	-S-FJ12FN8	1.84(46.7)	0.78(19.8)	0.96(24.4)	0.62(15.7)	1.13(28.6)	1.06(27.0)
3/4	3/4	-S-FJ12FN12	1.90(48.3)	0.81(20.6)	0.96(24.4)	0.62(15.7)	1.13(28.6)	1.31(33.3)
7/8	3/4	-S-FJ14FN12	1.96(49.8)	0.81(20.6)	1.02(25.9)	0.72(18.3)	1.25(31.8)	1.31(33.3)
1	3/4	-S-FJ16FN12	2.10(53.3)	0.81(20.6)	1.23(31.2)	0.88(22.4)	1.50(38.1)	1.37(34.9)
1	1	-S-FJ16FN16	2.45(62.2)	1.00(25.4)	1.23(31.2)	0.88(22.4)	1.50(38.1)	1.63(41.3)
1 1/4	1 1/4	-S-FJ20FN20	2.94(74.7)	1.00(25.4)	1.62(41.1)	1.09(27.7)	1.87(47.6)	2.13(54.0)
1 1/2	1 1/2	-S-FJ24FN24	3.30(83.8)	1.09(27.7)	1.97(50.0)	1.34(34.0)	2.25(57.2)	2.37(60.3)

英制 Tube管			ISO 锥螺纹 (RT)					
T-Tube 管外径 (in.)	P-RT 尺寸	基本 订购号	尺寸, in. (mm)					
			L	B	C	E	G	F
1/4	1/8	-S-FJ4FRT2	1.23(31.2)	0.41(10.4)	0.60(15.2)	0.19(4.8)	0.56(14.3)	0.56(14.3)
1/4	1/4	-S-FJ4FRT4	1.41(35.8)	0.59(15.0)	0.60(15.2)	0.19(4.8)	0.56(14.3)	0.75(19.1)
1/4	3/8	-S-FJ4FRT6	1.48(37.6)	0.59(15.0)	0.60(15.2)	0.19(4.8)	0.56(14.3)	0.87(22.2)
1/4	1/2	-S-FJ4FRT8	1.67(42.4)	0.78(19.8)	0.60(15.2)	0.19(4.8)	0.56(14.3)	1.06(27.0)
3/8	1/4	-S-FJ6FRT4	1.48(37.6)	0.59(15.0)	0.66(16.8)	0.28(7.1)	0.69(17.5)	0.75(19.1)
3/8	3/8	-S-FJ6FRT6	1.54(39.1)	0.59(15.0)	0.66(16.8)	0.28(7.1)	0.69(17.5)	0.87(22.2)
3/8	1/2	-S-FJ6FRT8	1.73(43.9)	0.78(19.8)	0.66(16.8)	0.28(7.1)	0.69(17.5)	1.06(27.0)
1/2	1/4	-S-FJ8FRT4	1.59(40.4)	0.59(15.0)	0.90(22.9)	0.41(10.4)	0.87(22.2)	0.81(20.6)
1/2	3/8	-S-FJ8FRT6	1.65(41.9)	0.59(15.0)	0.90(22.9)	0.41(10.4)	0.87(22.2)	0.87(22.2)
1/2	1/2	-S-FJ8FRT8	1.84(46.7)	0.78(19.8)	0.90(22.9)	0.41(10.4)	0.87(22.2)	1.06(27.0)

▶ 卡套阴螺纹接头

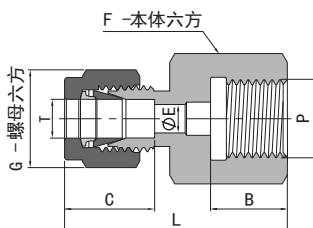
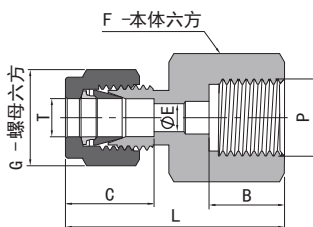

◆ 转接至日本压力表螺栓。

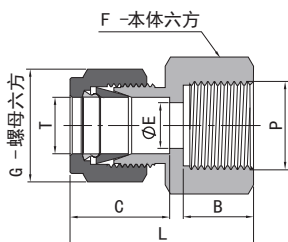

英制 Tube管			ISO 平行螺纹 (FG)					
T-Tube 管外径 (in.)	P-FG 尺寸	基本 订购号	尺寸, in. (mm)					
			L	B	C	E	G	F
1/8	1/4	-S-FJ2FG4	1.39(35.3)	0.51(12.9)	0.50(12.7)	0.09(2.3)	0.44(11.1)	0.75(19.1)
1/8	3/8	-S-FJ2FG6	1.52(38.7)	0.56(14.2)	0.50(12.7)	0.09(2.3)	0.44(11.1)	0.94(23.8)
1/4	1/4	-S-FJ4FG4	1.48(37.6)	0.51(12.9)	0.60(15.2)	0.19(4.8)	0.56(14.3)	0.75(19.1)
1/4	3/8	-S-FJ4FG6	1.48(37.6)	0.56(14.2)	0.60(15.2)	0.19(4.8)	0.56(14.3)	0.94(23.8)
1/4	1/2	-S-FJ4FG8	1.71(43.4)	0.74(18.8)	0.60(15.2)	0.19(4.8)	0.56(14.3)	1.06(27.0)
5/16	1/4	-S-FJ5FG4	1.51(38.4)	0.51(12.9)	0.64(16.3)	0.22(5.6)	0.63(15.9)	0.75(19.1)
5/16	3/8	-S-FJ5FG6	1.45(36.9)	0.56(14.2)	0.64(16.3)	0.25(6.4)	0.63(15.9)	0.94(23.8)
5/16	1/2	-S-FJ5FG8	1.61(40.9)	0.74(18.8)	0.64(16.3)	0.28(7.1)	0.63(15.9)	1.06(27.0)
3/8	1/4	-S-FJ6FG4	1.54(39.1)	0.51(12.9)	0.66(16.8)	0.22(5.6)	0.69(17.5)	0.75(19.1)
3/8	3/8	-S-FJ6FG6	1.52(38.6)	0.56(14.2)	0.66(16.8)	0.25(6.4)	0.69(17.5)	0.94(23.8)
3/8	1/2	-S-FJ6FG8	1.65(41.9)	0.74(18.8)	0.66(16.8)	0.28(7.1)	0.69(17.5)	1.06(27.0)
1/2	1/4	-S-FJ8FG4	1.65(41.9)	0.51(12.9)	0.90(22.9)	0.22(5.6)	0.87(22.2)	0.87(22.2)
1/2	3/8	-S-FJ8FG6	1.75(44.5)	0.56(14.2)	0.90(22.9)	0.25(6.4)	0.87(22.2)	0.94(23.8)
1/2	1/2	-S-FJ8FG8	1.90(48.3)	0.74(18.8)	0.90(22.9)	0.28(7.1)	0.87(22.2)	1.06(27.0)

英制 Tube管			ISO 平行螺纹 (RJ)					
T-Tube 管外径 (in.)	P-RJ 尺寸	基本 订购号	尺寸, in. (mm)					
			L	B	C	E	G	F
1/4	1/4	-S-FJ4RJ4	1.48(37.6)	0.51(12.9)	0.60(15.2)	0.18(4.6)	0.56(14.3)	0.75(19.1)
1/4	3/8	-S-FJ4RJ6	1.48(37.6)	0.62(15.8)	0.60(15.2)	0.19(4.8)	0.56(14.3)	0.94(23.8)
1/4	1/2	-S-FJ4RJ8	1.71(43.4)	0.74(18.8)	0.60(15.2)	0.19(4.8)	0.56(14.3)	1.06(27.0)
5/16	1/4	-S-FJ5RJ4	1.51(38.4)	0.51(12.9)	0.64(16.3)	0.22(5.6)	0.63(15.9)	0.75(19.1)
5/16	1/2	-S-FJ5RJ8	1.61(40.9)	0.74(18.8)	0.64(16.3)	0.28(7.1)	0.63(15.9)	1.06(27.0)
3/8	1/4	-S-FJ6RJ4	1.54(39.1)	0.51(12.9)	0.66(16.8)	0.22(5.6)	0.69(17.5)	0.75(19.1)
3/8	3/8	-S-FJ6RJ6	1.52(38.6)	0.62(15.8)	0.66(16.8)	0.25(6.4)	0.69(17.5)	0.94(23.8)
3/8	1/2	-S-FJ6RJ8	1.65(41.9)	0.74(18.8)	0.66(16.8)	0.28(7.1)	0.69(17.5)	1.06(27.0)
1/2	1/4	-S-FJ8RJ4	1.65(41.9)	0.51(12.9)	0.90(22.9)	0.22(5.6)	0.87(22.2)	0.81(20.6)
1/2	3/8	-S-FJ8RJ6	1.75(44.5)	0.62(15.8)	0.90(22.9)	0.25(6.4)	0.87(22.2)	0.94(23.8)
1/2	1/2	-S-FJ8RJ8	1.90(48.3)	0.74(18.8)	0.90(22.9)	0.28(7.1)	0.87(22.2)	1.06(27.0)

英制 Tube管			公制螺纹					
T-Tube 管外径 (in.)	P-公制 螺纹尺寸	基本 订购号	尺寸, in. (mm)					
			L	B	C	E	G	F
1/8	M14 x 1.5	-S-FJ2FM14	1.22(31.0)	0.51(13.0)	0.50(12.7)	0.09(2.3)	0.44(11.1)	0.75(19.1)
1/8	M16 x 1.5	-S-FJ2FM16	1.31(33.3)	0.55(14.0)	0.50(12.7)	0.09(2.3)	0.44(11.1)	0.87(22.2)
1/8	M18 x 1.5	-S-FJ2FM18	1.35(34.3)	0.59(15.0)	0.50(12.7)	0.09(2.3)	0.44(11.1)	1.00(25.4)
1/8	M20 x 1.5	-S-FJ2FM20	1.39(35.3)	0.63(16.0)	0.50(12.7)	0.09(2.3)	0.44(11.1)	1.06(27.0)
1/4	M16 x 1.5	-S-FJ4FM16	1.41(35.8)	0.55(14.0)	0.60(15.2)	0.19(4.8)	0.56(14.3)	0.87(22.2)
1/4	M18 x 1.5	-S-FJ4FM18	1.45(36.8)	0.59(15.0)	0.60(15.2)	0.19(4.8)	0.56(14.3)	1.00(25.4)
1/4	M20 x 1.5	-S-FJ4FM20	1.49(37.8)	0.63(16.0)	0.60(15.2)	0.19(4.8)	0.56(14.3)	1.06(27.0)
3/8	M14 x 1.5	-S-FJ6FM14	1.46(37.1)	0.51(13.0)	0.66(16.8)	0.28(7.1)	0.69(17.5)	0.75(19.1)
3/8	M16 x 1.5	-S-FJ6FM16	1.48(37.5)	0.55(14.0)	0.66(16.8)	0.28(7.1)	0.69(17.5)	0.87(22.2)
3/8	M18 x 1.5	-S-FJ6FM18	1.52(38.5)	0.59(15.0)	0.66(16.8)	0.28(7.1)	0.69(17.5)	1.00(25.4)
3/8	M20 x 1.5	-S-FJ6FM20	1.56(39.5)	0.63(16.0)	0.66(16.8)	0.28(7.1)	0.69(17.5)	1.06(27.0)
1/2	M16 x 1.5	-S-FJ8FM16	1.63(41.4)	0.55(14.0)	0.90(22.9)	0.33(8.4)	0.87(22.2)	0.87(22.2)
1/2	M18 x 1.5	-S-FJ8FM18	1.67(42.4)	0.59(15.0)	0.90(22.9)	0.38(9.6)	0.87(22.2)	1.00(25.4)
1/2	M20 x 1.5	-S-FJ8FM20	1.71(43.4)	0.63(16.0)	0.90(22.9)	0.41(10.4)	0.87(22.2)	1.06(27.0)
1/2	M22 x 1.5	-S-FJ8FM22	1.65(41.9)	0.63(16.0)	0.90(22.9)	0.38(9.7)	0.87(22.2)	1.06(27.0)

▶ 卡套阴螺纹接头

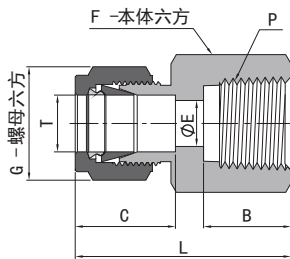

公制 Tube管			NPT螺纹					
T-Tube 管外径 (mm)	P-NPT 尺寸	基本 订购号	尺寸, mm (in.)					
			L	B	C	E	G	F
3	1/8	-S-MJ3FN2	28.7(1.13)	10.4(0.41)	12.9(0.51)	2.4(0.09)	12.0(0.47)	14.0(0.55)
3	1/4	-S-MJ3FN4	33.5(1.32)	15.0(0.59)	12.9(0.51)	2.4(0.09)	12.0(0.47)	19.0(0.75)
4	1/8	-S-MJ4FN2	29.7(1.17)	10.4(0.41)	13.7(0.54)	2.4(0.09)	12.0(0.47)	14.0(0.55)
6	1/8	-S-MJ6FN2	31.3(1.23)	10.4(0.41)	15.3(0.60)	4.8(0.19)	14.0(0.55)	14.0(0.55)
6	1/4	-S-MJ6FN4	35.8(1.41)	15.0(0.59)	15.3(0.60)	4.8(0.19)	14.0(0.55)	19.0(0.75)
6	3/8	-S-MJ6FN6	37.7(1.48)	15.0(0.59)	15.3(0.60)	4.8(0.19)	14.0(0.55)	22.0(0.87)
6	1/2	-S-MJ6FN8	42.5(1.67)	19.8(0.78)	15.3(0.60)	4.8(0.19)	14.0(0.55)	27.0(1.06)
8	1/8	-S-MJ8FN2	32.1(1.26)	10.4(0.41)	16.2(0.64)	6.4(0.25)	16.0(0.63)	15.0(0.59)
8	1/4	-S-MJ8FN4	37.0(1.46)	15.0(0.59)	16.2(0.64)	6.4(0.25)	16.0(0.63)	19.0(0.75)
8	3/8	-S-MJ8FN6	38.5(1.52)	15.0(0.59)	16.2(0.64)	6.4(0.25)	16.0(0.63)	22.0(0.87)
8	1/2	-S-MJ8FN8	43.3(1.70)	19.8(0.78)	16.2(0.64)	6.4(0.25)	16.0(0.63)	27.0(1.06)
10	1/8	-S-MJ10FN2	33.0(1.30)	10.4(0.41)	17.2(0.68)	7.9(0.31)	19.0(0.75)	18.0(0.71)
10	1/4	-S-MJ10FN4	37.8(1.49)	15.0(0.59)	17.2(0.68)	7.9(0.31)	19.0(0.75)	19.0(0.75)
10	3/8	-S-MJ10FN6	39.4(1.55)	15.0(0.59)	17.2(0.68)	7.9(0.31)	19.0(0.75)	22.0(0.87)
10	1/2	-S-MJ10FN8	44.2(1.74)	19.8(0.78)	17.2(0.68)	7.9(0.31)	19.0(0.75)	27.0(1.06)
12	1/4	-S-MJ12FN4	40.3(1.59)	15.0(0.59)	22.8(0.90)	9.5(0.37)	22.0(0.87)	22.0(0.87)
12	3/8	-S-MJ12FN6	41.9(1.65)	15.0(0.59)	22.8(0.90)	9.5(0.37)	22.0(0.87)	22.0(0.87)
12	1/2	-S-MJ12FN8	46.7(1.84)	19.8(0.78)	22.8(0.90)	9.5(0.37)	22.0(0.87)	27.0(1.06)
12	3/4	-S-MJ12FN12	49.1(1.93)	20.6(0.81)	22.8(0.90)	9.5(0.37)	22.0(0.87)	35.0(1.38)
14	3/4	-S-MJ14FN12	49.7(1.96)	20.6(0.81)	24.4(0.96)	11.1(0.44)	25.0(0.98)	35.0(1.38)
15	1/2	-S-MJ15FN8	46.7(1.84)	19.8(0.78)	24.4(0.96)	11.9(0.47)	25.0(0.98)	27.0(1.06)
16	3/8	-S-MJ16FN6	41.9(1.65)	15.0(0.59)	24.4(0.96)	12.7(0.50)	25.0(0.98)	27.0(1.06)
16	1/2	-S-MJ16FN8	46.9(1.85)	19.8(0.78)	24.4(0.96)	12.7(0.50)	25.0(0.98)	27.0(1.06)
20	1/2	-S-MJ20FN8	47.9(1.89)	19.8(0.78)	26.0(1.02)	15.9(0.63)	32.0(1.26)	30.0(1.18)
20	3/4	-S-MJ20FN12	49.7(1.96)	20.6(0.81)	26.0(1.02)	15.9(0.63)	32.0(1.26)	35.0(1.38)
22	3/4	-S-MJ22FN12	49.7(1.96)	20.6(0.81)	26.0(1.02)	18.3(0.72)	32.0(1.26)	35.0(1.38)
22	1	-S-MJ22FN16	57.9(2.28)	25.4(1.00)	26.0(1.02)	18.3(0.72)	32.0(1.26)	41.0(1.61)
25	3/4	-S-MJ25FN12	53.4(2.10)	20.6(0.81)	31.3(1.23)	21.8(0.86)	38.0(1.50)	35.0(1.38)
25	1	-S-MJ25FN16	62.3(2.45)	25.4(1.00)	31.3(1.23)	21.8(0.86)	38.0(1.50)	41.0(1.61)

► 卡套阴螺纹接头

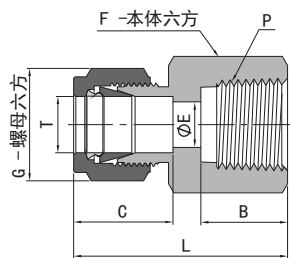

公制 Tube管			ISO 锥螺纹 (RT)					
T-Tube 管外径 (mm)	P-RT 尺寸	基本 订购号	尺寸, mm (in.)					
			L	B	C	E	G	F
3	1/8	-S-MJ3FRT2	28.7(1.13)	10.4(0.41)	12.9(0.51)	2.4(0.09)	12.0(0.47)	14.0(0.55)
6	1/8	-S-MJ6FRT2	31.3(1.23)	10.4(0.41)	15.3(0.60)	4.8(0.19)	14.0(0.55)	14.0(0.55)
6	1/4	-S-MJ6FRT4	35.8(1.41)	15.0(0.59)	15.3(0.60)	4.8(0.19)	14.0(0.55)	19.0(0.75)
6	3/8	-S-MJ6FRT6	37.9(1.49)	15.0(0.59)	15.3(0.60)	4.8(0.19)	14.0(0.55)	22.0(0.87)
6	1/2	-S-MJ6FRT8	42.5(1.67)	19.8(0.78)	15.3(0.60)	4.8(0.19)	14.0(0.55)	27.0(1.06)
8	1/8	-S-MJ8FRT2	32.1(1.26)	10.4(0.41)	16.2(0.64)	6.4(0.25)	16.0(0.63)	15.0(0.59)
8	1/4	-S-MJ8FRT4	37.0(1.46)	15.0(0.59)	16.2(0.64)	6.4(0.25)	16.0(0.63)	19.0(0.75)
8	3/8	-S-MJ8FRT6	38.5(1.52)	15.0(0.59)	16.2(0.64)	6.4(0.25)	16.0(0.63)	22.0(0.87)
8	1/2	-S-MJ8FRT8	43.3(1.70)	19.8(0.78)	16.2(0.64)	6.4(0.25)	16.0(0.63)	27.0(1.06)
10	1/8	-S-MJ10FRT2	33.0(1.30)	10.4(0.41)	17.2(0.68)	7.9(0.31)	19.0(0.75)	18.0(0.71)
10	1/4	-S-MJ10FRT4	37.8(1.49)	15.0(0.59)	17.2(0.68)	7.9(0.31)	19.0(0.75)	19.0(0.75)
10	3/8	-S-MJ10FRT6	39.4(1.55)	15.0(0.59)	17.2(0.68)	7.9(0.31)	19.0(0.75)	22.0(0.87)
10	1/2	-S-MJ10FRT8	44.2(1.74)	19.8(0.78)	17.2(0.68)	7.9(0.31)	19.0(0.75)	27.0(1.06)
12	1/8	-S-MJ12FRT2	35.5(1.40)	10.4(0.41)	22.8(0.90)	8.3(0.33)	22.0(0.87)	22.0(0.87)
12	1/4	-S-MJ12FRT4	40.3(1.59)	15.0(0.59)	22.8(0.90)	9.5(0.37)	22.0(0.87)	22.0(0.87)
12	3/8	-S-MJ12FRT6	41.9(1.65)	15.0(0.59)	22.8(0.90)	9.5(0.37)	22.0(0.87)	22.0(0.87)
12	1/2	-S-MJ12FRT8	46.7(1.84)	19.8(0.78)	22.8(0.90)	9.5(0.37)	22.0(0.87)	27.0(1.06)
12	3/4	-S-MJ12FRT12	49.0(1.93)	20.6(0.81)	22.8(0.90)	9.5(0.37)	22.0(0.87)	35.0(1.38)
15	1/2	-S-MJ15FRT8	46.7(1.84)	19.8(0.78)	24.4(0.96)	11.9(0.47)	25.0(0.98)	27.0(1.06)
16	1/2	-S-MJ16FRT8	48.4(1.91)	19.8(0.78)	24.4(0.96)	12.7(0.50)	25.0(0.98)	27.0(1.06)
16	3/4	-S-MJ16FRT12	49.7(1.96)	20.6(0.81)	24.4(0.96)	12.7(0.50)	25.0(0.98)	35.0(1.38)
20	1/2	-S-MJ20FRT8	47.9(1.89)	19.8(0.78)	26.0(1.02)	15.9(0.63)	32.0(1.26)	30.0(1.18)
20	3/4	-S-MJ20FRT12	49.7(1.96)	20.6(0.81)	26.0(1.02)	15.9(0.63)	32.0(1.26)	35.0(1.38)
22	3/4	-S-MJ22FRT12	49.7(1.96)	20.6(0.81)	26.0(1.02)	18.3(0.72)	32.0(1.26)	35.0(1.38)
22	1	-S-MJ22FRT16	57.9(2.28)	25.4(1.00)	26.0(1.02)	18.3(0.72)	32.0(1.26)	41.0(1.61)
25	3/4	-S-MJ25FRT12	53.4(2.10)	20.6(0.81)	31.3(1.23)	21.8(0.86)	38.0(1.50)	35.0(1.38)
25	1	-S-MJ25FRT16	62.3(2.45)	25.4(1.00)	31.3(1.23)	21.8(0.86)	38.0(1.50)	41.0(1.61)

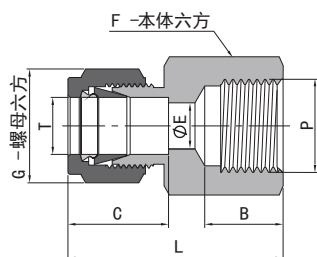

公制 Tube管			ISO 平行螺纹 (BR)					
T-Tube 管外径 (mm)	P-BR 尺寸	基本 订购号	尺寸, mm (in.)					
			L	B	C	E	G	F
6	1/8	-S-MJ6FP2	33.5(1.32)	10.5(0.41)	15.3(0.60)	4.8(0.19)	14.0(0.55)	14.0(0.55)
6	1/4	-S-MJ6FP4	39.4(1.55)	15.5(0.61)	15.3(0.60)	4.8(0.19)	14.0(0.55)	19.0(0.75)
22	3/4	-S-MJ22FP12	53.3(2.10)	20.5(0.81)	26.0(1.02)	18.3(0.72)	32.0(1.26)	35.0(1.38)
25	1	-S-MJ25FP16	63.9(2.52)	23.5(0.93)	31.3(1.23)	21.8(0.86)	38.0(1.50)	40.0(1.57)

▶ 卡套阴螺纹接头

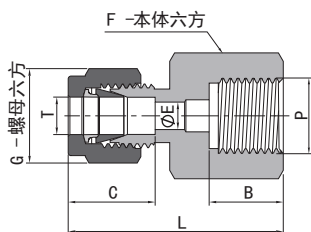

公制 Tube管			ISO 平行螺纹 (FG)					
T-Tube 管外径 (mm)	P-FG 尺寸	基本 订购号	尺寸, mm (in.)					
			L	B	C	E	G	F
3	1/4	-S-MJ3FG4	35.3(1.39)	12.9(0.51)	12.9(0.51)	2.4(0.09)	12.0(0.47)	19.0(0.75)
6	1/4	-S-MJ6FG4	37.6(1.48)	12.9(0.51)	15.3(0.60)	4.8(0.19)	14.0(0.55)	19.0(0.75)
6	3/8	-S-MJ6FG6	37.6(1.48)	14.2(0.56)	15.3(0.60)	4.8(0.19)	14.0(0.55)	24.0(0.94)
6	1/2	-S-MJ6FG8	43.5(1.71)	18.8(0.74)	15.3(0.60)	4.8(0.19)	14.0(0.55)	27.0(1.06)
8	1/4	-S-MJ8FG4	38.5(1.52)	12.9(0.51)	16.2(0.64)	5.5(0.22)	16.0(0.63)	19.0(0.75)
8	3/8	-S-MJ8FG6	36.2(1.43)	14.2(0.56)	16.2(0.64)	6.4(0.25)	16.0(0.63)	24.0(0.94)
8	1/2	-S-MJ8FG8	41.0(1.61)	18.8(0.74)	16.2(0.64)	6.4(0.25)	16.0(0.63)	27.0(1.06)
10	1/4	-S-MJ10FG4	39.4(1.55)	12.9(0.51)	17.2(0.68)	5.5(0.22)	19.0(0.75)	19.0(0.75)
10	3/8	-S-MJ10FG6	38.8(1.53)	14.2(0.56)	17.2(0.68)	6.4(0.25)	19.0(0.75)	24.0(0.94)
10	1/2	-S-MJ10FG8	42.1(1.66)	18.8(0.74)	17.2(0.68)	7.9(0.31)	19.0(0.75)	27.0(1.06)
12	1/4	-S-MJ12FG4	41.9(1.65)	12.9(0.51)	22.8(0.90)	5.5(0.22)	22.0(0.87)	22.0(0.87)
12	3/8	-S-MJ12FG6	44.4(1.75)	14.2(0.56)	22.8(0.90)	6.4(0.25)	22.0(0.87)	24.0(0.94)
12	1/2	-S-MJ12FG8	48.2(1.90)	18.8(0.74)	22.8(0.90)	7.1(0.28)	22.0(0.87)	27.0(1.06)
20	1/2	-S-MJ20FG8	54.3(2.14)	18.8(0.74)	26.0(1.02)	7.1(0.28)	32.0(1.26)	30.0(1.18)
22	1/2	-S-MJ22FG8	54.3(2.14)	18.8(0.74)	26.0(1.02)	7.1(0.28)	32.0(1.26)	30.0(1.18)

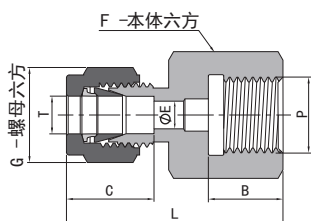

◆ 转接至日本压力表螺栓。

公制 Tube管			ISO 平行螺纹 (RJ)					
T-Tube 管外径 (mm)	P-RJ 尺寸	基本 订购号	尺寸, mm (in.)					
			L	B	C	E	G	F
6	1/4	-S-MJ6RJ4	37.6(1.48)	12.9(0.51)	15.3(0.60)	4.8(0.19)	14.0(0.55)	19.0(0.75)
6	3/8	-S-MJ6RJ6	37.6(1.48)	15.8(0.62)	15.3(0.60)	4.8(0.19)	14.0(0.55)	24.0(0.94)
6	1/2	-S-MJ6RJ8	43.5(1.71)	18.8(0.74)	15.3(0.60)	4.8(0.19)	14.0(0.55)	27.0(1.06)
8	1/4	-S-MJ8RJ4	38.5(1.52)	12.9(0.51)	16.2(0.64)	5.5(0.22)	16.0(0.63)	19.0(0.75)
8	3/8	-S-MJ8RJ6	36.2(1.43)	15.8(0.62)	16.2(0.64)	6.5(0.26)	16.0(0.63)	24.0(0.94)
8	1/2	-S-MJ8RJ8	41.0(1.61)	18.8(0.74)	16.2(0.64)	7.0(0.28)	16.0(0.63)	27.0(1.06)
10	1/4	-S-MJ10RJ4	39.4(1.55)	12.9(0.51)	17.2(0.68)	5.5(0.22)	19.0(0.75)	19.0(0.75)
10	3/8	-S-MJ10RJ6	38.8(1.53)	15.8(0.62)	17.2(0.68)	6.5(0.26)	19.0(0.75)	24.0(0.94)
10	1/2	-S-MJ10RJ8	42.1(1.66)	18.8(0.74)	17.2(0.68)	7.0(0.28)	19.0(0.75)	27.0(1.06)
12	1/4	-S-MJ12RJ4	41.9(1.65)	12.9(0.51)	22.8(0.90)	5.5(0.22)	22.0(0.87)	22.0(0.87)
12	3/8	-S-MJ12RJ6	44.4(1.75)	15.8(0.62)	22.8(0.90)	6.5(0.26)	22.0(0.87)	24.0(0.94)
12	1/2	-S-MJ12RJ8	48.2(1.90)	18.8(0.74)	22.8(0.90)	7.0(0.28)	22.0(0.87)	27.0(1.06)

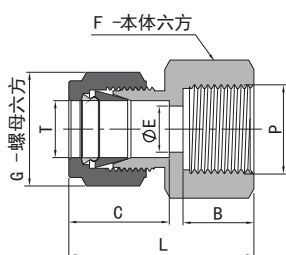

公制 Tube管			公制螺纹					
T-Tube 管外径 (mm)	P-公制 螺纹尺寸	基本 订购号	尺寸, mm (in.)					
			L	B	C	E	G	F
6	M10 x 1	-S-MJ6FM10	32.7(1.29)	11.0(0.43)	15.3(0.60)	4.7(0.19)	14.0(0.55)	16.0(0.63)
6	M14 x 1.5	-S-MJ6FM14	36.1(1.42)	13.0(0.51)	15.3(0.60)	4.8(0.19)	14.0(0.55)	19.0(0.75)
6	M20 x 1.5	-S-MJ6FM20	37.7(1.48)	16.0(0.63)	15.3(0.60)	4.8(0.19)	14.0(0.55)	27.0(1.06)
8	M8 x 1	-S-MJ8FM8	31.6(1.24)	9.0(0.35)	16.2(0.64)	3.0(0.12)	16.0(0.63)	14.0(0.55)
8	M10 x 1	-S-MJ8FM10	33.6(1.32)	11.0(0.43)	16.2(0.64)	4.0(0.16)	16.0(0.63)	16.0(0.63)
8	M14 x 1.5	-S-MJ8FM14	35.6(1.40)	13.0(0.51)	16.2(0.64)	6.4(0.25)	16.0(0.63)	19.0(0.75)
8	M20 x 1.5	-S-MJ8FM20	38.6(1.52)	16.0(0.63)	16.2(0.64)	6.4(0.25)	16.0(0.63)	27.0(1.06)
10	M16 x 1.5	-S-MJ10FM16	38.1(1.50)	14.0(0.55)	17.2(0.68)	7.9(0.31)	19.0(0.75)	22.0(0.87)
12	M20 x 1.5	-S-MJ12FM20	44.9(1.77)	16.0(0.63)	22.8(0.90)	9.5(0.37)	22.0(0.87)	27.0(1.06)
14	M10 x 1	-S-MJ14FM10	42.5(1.67)	11.0(0.43)	24.4(0.96)	4.0(0.16)	25.0(0.98)	24.0(0.94)
14	M20 x 1.5	-S-MJ14FM20	44.9(1.77)	16.0(0.63)	24.4(0.96)	10.8(0.43)	25.0(0.98)	27.0(1.06)
14	M22 x 1.5	-S-MJ14FM22	45.9(1.81)	17.0(0.67)	24.4(0.96)	11.1(0.44)	25.0(0.98)	27.0(1.06)
16	M20 x 1.5	-S-MJ16FM20	44.9(1.77)	16.0(0.63)	24.4(0.96)	10.8(0.43)	25.0(0.98)	27.0(1.06)
20	M20 x 1.5	-S-MJ20FM20	46.5(1.83)	16.0(0.63)	26.0(1.02)	10.8(0.43)	32.0(1.26)	30.0(1.18)
25	M27 x 2	-S-MJ25FM27	54.4(2.14)	18.0(0.71)	31.3(1.23)	16.1(0.63)	38.0(1.50)	35.0(1.38)

▶ 卡套阴螺纹穿板接头

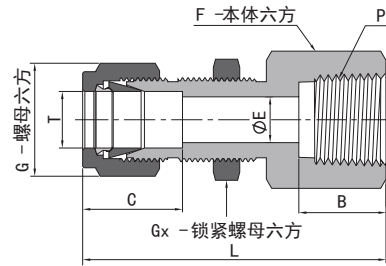

英制 Tube管										NPT 螺纹	
T-Tube 管外径 (in.)	P-NPT 尺寸	基本 订购号	尺寸, in. (mm)							面板孔 尺寸 in. (mm)	最大面板 厚度 in. (mm)
			L	B	C	E	G	F	Gx		
1/16	1/16	-S-BFJ1FN1	1.19(30.2)	0.39(9.9)	0.34(8.6)	0.05(1.3)	0.31(7.9)	0.44(11.1)	0.31(7.9)	0.20(5.2)	0.13(3.2)
1/16	1/8	-S-BFJ1FN2	1.20(30.7)	0.41(10.4)	0.34(8.6)	0.05(1.3)	0.31(7.9)	0.56(14.3)	0.31(7.9)	0.20(5.2)	0.13(3.2)
1/8	1/8	-S-BFJ2FN2	1.76(44.7)	0.41(10.4)	0.50(12.7)	0.09(2.3)	0.44(11.1)	0.56(14.3)	0.50(12.7)	0.33(8.3)	0.50(12.7)
1/8	1/4	-S-BFJ2FN4	1.95(49.6)	0.59(15.0)	0.50(12.7)	0.09(2.3)	0.44(11.1)	0.75(19.1)	0.50(12.7)	0.33(8.3)	0.50(12.7)
3/16	1/8	-S-BFJ3FN2	1.79(45.5)	0.41(10.4)	0.54(13.7)	0.12(3.0)	0.50(12.7)	0.56(14.3)	0.56(14.3)	0.39(9.9)	0.50(12.7)
1/4	1/8	-S-BFJ4FN2	1.85(47.0)	0.41(10.4)	0.60(15.2)	0.19(4.8)	0.56(14.3)	0.63(15.9)	0.63(15.9)	0.45(11.5)	0.40(10.2)
1/4	1/4	-S-BFJ4FN4	2.04(51.8)	0.59(15.0)	0.60(15.2)	0.19(4.8)	0.56(14.3)	0.75(19.1)	0.63(15.9)	0.45(11.5)	0.40(10.2)
1/4	3/8	-S-BFJ4FN6	2.10(53.3)	0.59(15.0)	0.60(15.2)	0.19(4.8)	0.56(14.3)	0.87(22.2)	0.63(15.9)	0.45(11.5)	0.40(10.2)
1/4	1/2	-S-BFJ4FN8	2.29(58.2)	0.78(19.8)	0.60(15.2)	0.19(4.8)	0.56(14.3)	1.06(27.0)	0.63(15.9)	0.45(11.5)	0.40(10.2)
5/16	1/8	-S-BFJ5FN2	1.96(49.8)	0.41(10.4)	0.64(16.3)	0.25(6.4)	0.63(15.9)	0.69(17.5)	0.69(17.5)	0.52(13.1)	0.44(11.2)
5/16	1/4	-S-BFJ5FN4	2.38(60.5)	0.59(15.0)	0.64(16.3)	0.25(6.4)	0.63(15.9)	0.75(19.1)	0.69(17.5)	0.52(13.1)	0.44(11.2)
3/8	1/8	-S-BFJ6FN2	1.98(50.3)	0.41(10.4)	0.66(16.8)	0.28(7.1)	0.69(17.5)	0.75(19.1)	0.75(19.1)	0.58(14.7)	0.44(11.2)
3/8	1/4	-S-BFJ6FN4	2.17(55.1)	0.59(15.0)	0.66(16.8)	0.28(7.1)	0.69(17.5)	0.75(19.1)	0.75(19.1)	0.58(14.7)	0.44(11.2)
3/8	3/8	-S-BFJ6FN6	2.23(56.6)	0.59(15.0)	0.66(16.8)	0.28(7.1)	0.69(17.5)	0.87(22.2)	0.75(19.1)	0.58(14.7)	0.44(11.2)
3/8	1/2	-S-BFJ6FN8	2.42(61.5)	0.78(19.8)	0.66(16.8)	0.28(7.1)	0.69(17.5)	1.06(27.0)	0.75(19.1)	0.58(14.7)	0.44(11.2)
3/8	3/4	-S-BFJ6FN12	2.57(65.3)	0.81(20.6)	0.66(16.8)	0.28(7.1)	0.69(17.5)	1.31(33.3)	0.75(19.1)	0.58(14.7)	0.44(11.2)
1/2	1/4	-S-BFJ8FN4	2.37(60.2)	0.59(15.0)	0.90(22.9)	0.41(10.4)	0.87(22.2)	0.94(23.8)	0.94(23.8)	0.76(19.4)	0.50(12.7)
1/2	3/8	-S-BFJ8FN6	2.43(61.7)	0.59(15.0)	0.90(22.9)	0.41(10.4)	0.87(22.2)	0.94(23.8)	0.94(23.8)	0.76(19.4)	0.50(12.7)
1/2	1/2	-S-BFJ8FN8	2.62(66.5)	0.78(19.8)	0.90(22.9)	0.41(10.4)	0.87(22.2)	1.06(27.0)	0.94(23.8)	0.76(19.4)	0.50(12.7)
1/2	3/4	-S-BFJ8FN12	2.68(68.1)	0.81(20.6)	0.90(22.9)	0.41(10.4)	0.87(22.2)	1.31(33.3)	0.94(23.8)	0.76(19.4)	0.50(12.7)
5/8	3/8	-S-BFJ10FN6	2.46(62.5)	0.59(15.0)	0.96(24.4)	0.50(12.7)	1.00(25.4)	1.06(27.0)	1.06(27.0)	0.89(22.6)	0.59(15.1)
5/8	1/2	-S-BFJ10FN8	2.65(67.3)	0.78(19.8)	0.96(24.4)	0.50(12.7)	1.00(25.4)	1.06(27.0)	1.06(27.0)	0.89(22.6)	0.59(15.1)
3/4	1/2	-S-BFJ12FN8	2.84(72.2)	0.78(19.8)	0.96(24.4)	0.62(15.7)	1.13(28.6)	1.19(30.2)	1.19(30.2)	1.02(25.8)	0.78(19.8)
3/4	3/4	-S-BFJ12FN12	2.90(73.7)	0.81(20.6)	0.96(24.4)	0.62(15.7)	1.13(28.6)	1.31(33.3)	1.19(30.2)	1.02(25.8)	0.78(19.8)
7/8	3/4	-S-BFJ14FN12	3.18(80.8)	0.81(20.6)	1.02(25.9)	0.72(18.3)	1.25(31.8)	1.31(33.3)	1.31(33.3)	1.14(29.0)	0.94(23.8)
1	3/4	-S-BFJ16FN12	3.33(84.7)	0.81(20.6)	1.23(31.2)	0.88(22.4)	1.50(38.1)	1.63(41.3)	1.63(41.3)	1.33(33.7)	0.94(23.8)
1	1	-S-BFJ16FN16	3.68(93.5)	1.00(25.4)	1.23(31.2)	0.88(22.4)	1.50(38.1)	1.63(41.3)	1.63(41.3)	1.33(33.7)	0.94(23.8)

公制 Tube管										NPT 螺纹	
T-Tube O.D. (mm)	P-NPT 尺寸	基本 订购号	尺寸, mm (in.)							面板孔 尺寸 mm (in.)	最大面板 厚度 mm (in.)
			L	B	C	E	G	F	Gx		
6	1/8	-S-BMJ6FN2	47.2(1.86)	10.4(0.41)	15.3(0.60)	4.8(0.19)	14.0(0.55)	16.0(0.63)	16.0(0.63)	11.5(0.45)	10.2(0.40)
6	1/4	-S-BMJ6FN4	51.8(2.04)	15.0(0.59)	15.3(0.60)	4.8(0.19)	14.0(0.55)	19.0(0.75)	16.0(0.63)	11.5(0.45)	10.2(0.40)
8	1/8	-S-BMJ8FN2	49.6(1.95)	10.4(0.41)	16.2(0.64)	6.4(0.25)	16.0(0.63)	18.0(0.71)	18.0(0.71)	13.1(0.52)	11.2(0.44)
10	1/4	-S-BMJ10FN4	55.2(2.17)	15.0(0.59)	17.2(0.68)	7.9(0.31)	19.0(0.75)	22.0(0.87)	22.0(0.87)	16.3(0.64)	11.2(0.44)
12	3/8	-S-BMJ12FN6	62.9(2.48)	15.0(0.59)	22.8(0.90)	9.5(0.37)	22.0(0.87)	24.0(0.94)	24.0(0.94)	19.5(0.77)	12.7(0.50)
12	1/2	-S-BMJ12FN8	66.5(2.62)	19.8(0.78)	22.8(0.90)	9.5(0.37)	22.0(0.87)	27.0(1.06)	24.0(0.94)	19.5(0.77)	12.7(0.50)

▶ 卡套直通接头

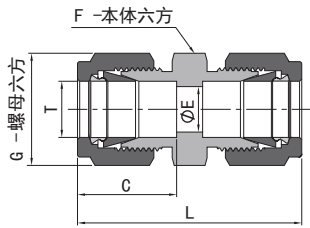

英制 Tube管

T-Tube 管外径 (in.)	基本 订购号	尺寸, in. (mm)				
		L	C	G	F	E
1/16	-S-FJ1	0.99(25.1)	0.34(8.6)	0.31(7.9)	0.31(7.9)	0.05(1.3)
1/8	-S-FJ2	1.40(35.6)	0.50(12.7)	0.44(11.1)	0.44(11.1)	0.09(2.3)
3/16	-S-FJ3	1.47(37.3)	0.54(13.7)	0.50(12.7)	0.50(12.7)	0.12(3.0)
1/4	-S-FJ4	1.61(40.9)	0.60(15.2)	0.56(14.3)	0.50(12.7)	0.19(4.8)
5/16	-S-FJ5	1.69(42.9)	0.64(16.2)	0.63(15.9)	0.56(14.3)	0.25(6.4)
3/8	-S-FJ6	1.77(45.0)	0.66(16.8)	0.69(17.5)	0.63(15.9)	0.28(7.1)
1/2	-S-FJ8	2.02(51.3)	0.90(22.9)	0.87(22.2)	0.81(20.6)	0.41(10.4)
5/8	-S-FJ10	2.05(52.1)	0.96(24.4)	1.00(25.4)	0.94(23.9)	0.50(12.7)
3/4	-S-FJ12	2.11(53.6)	0.96(24.4)	1.13(28.6)	1.06(27.0)	0.62(15.7)
7/8	-S-FJ14	2.19(55.7)	1.02(25.9)	1.25(31.8)	1.19(30.2)	0.72(18.3)
1	-S-FJ16	2.55(64.8)	1.23(31.2)	1.5(38.1)	1.37(34.9)	0.88(22.4)
1 1/8	-S-FJ18	3.47(88.2)	1.44(36.7)	1.75(44.5)	1.63(41.3)	0.97(24.6)
1 1/4	-S-FJ20	3.63(92.2)	1.62(41.1)	1.87(47.6)	1.75(44.5)	1.09(27.7)
1 1/2	-S-FJ24	4.25(108.0)	1.97(50.0)	2.25(57.2)	2.13(54.0)	1.34(34.0)

公制 Tube管

T-Tube 管外径 (mm)	基本 订购号	尺寸, mm (in.)				
		L	C	G	F	E
2	-S-MJ2	35.6(1.40)	12.9(0.51)	12.0(0.47)	12.0(0.47)	1.7(0.07)
3	-S-MJ3	35.3(1.39)	12.9(0.51)	12.0(0.47)	12.0(0.47)	2.4(0.09)
4	-S-MJ4	37.3(1.47)	13.7(0.54)	12.0(0.47)	12.0(0.47)	2.4(0.09)
6	-S-MJ6	41.0(1.61)	15.3(0.60)	14.0(0.55)	14.0(0.55)	4.8(0.19)
8	-S-MJ8	43.2(1.70)	16.2(0.64)	16.0(0.63)	15.0(0.59)	6.4(0.25)
10	-S-MJ10	46.2(1.82)	17.2(0.68)	19.0(0.75)	18.0(0.71)	7.9(0.31)
12	-S-MJ12	51.2(2.02)	22.8(0.90)	22.0(0.87)	22.0(0.87)	9.5(0.37)
14	-S-MJ14	52.0(2.05)	24.4(0.96)	25.0(0.98)	24.0(0.94)	11.1(0.44)
15	-S-MJ15	52.0(2.05)	24.4(0.96)	25.0(0.98)	24.0(0.94)	11.9(0.47)
16	-S-MJ16	52.0(2.05)	24.4(0.96)	25.0(0.98)	24.0(0.94)	12.7(0.50)
18	-S-MJ18	53.5(2.11)	24.4(0.96)	30.0(1.18)	27.0(1.06)	15.1(0.59)
20	-S-MJ20	55.0(2.17)	26.0(1.02)	32.0(1.26)	30.0(1.18)	15.9(0.63)
22	-S-MJ22	55.0(2.17)	26.0(1.02)	32.0(1.26)	30.0(1.18)	18.3(0.72)
25	-S-MJ25	65.0(2.56)	31.3(1.23)	38.0(1.50)	35.0(1.38)	21.8(0.86)
28	-S-MJ28	85.0(3.35)	36.6(1.44)	46.0(1.81)	41.0(1.61)	21.8(0.86)
30	-S-MJ30	92.7(3.65)	39.6(1.56)	50.0(1.97)	46.0(1.81)	26.2(1.03)
32	-S-MJ32	97.3(3.83)	42.0(1.65)	50.0(1.97)	46.0(1.81)	28.6(1.13)
38	-S-MJ38	113.6(4.47)	49.4(1.94)	60.0(2.36)	55.0(2.17)	33.7(1.33)

▶ 卡套直通转换接头

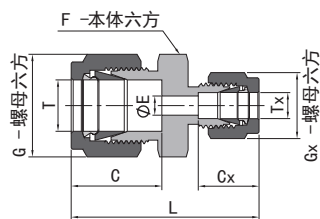

英制 Tube管			公制 Tube管							
T-Tube 管外径 (in.)	Tx-Tube 管外径 (mm)	基本 订购号	尺寸, in. (mm)							
			L	C	G	F	E	Cx	Gx	
1/8	3	-S-FJ2MJ3	1.39(35.2)	0.50(12.7)	0.44(11.1)	0.47(12.0)	0.09(2.3)	0.51(12.9)	0.47(12.0)	
1/4	4	-S-FJ4MJ4	1.55(39.4)	0.60(15.2)	0.56(14.3)	0.55(14.0)	0.09(2.4)	0.54(13.7)	0.47(12.0)	
1/4	6	-S-FJ4MJ6	1.62(41.2)	0.60(15.2)	0.56(14.3)	0.55(14.0)	0.19(4.8)	0.60(15.3)	0.55(14.0)	
3/8	6	-S-FJ6MJ6	1.72(43.7)	0.66(16.8)	0.69(17.5)	0.63(16.0)	0.19(4.8)	0.60(15.3)	0.55(14.0)	
3/8	8	-S-FJ6MJ8	1.75(44.5)	0.66(16.8)	0.69(17.5)	0.63(16.0)	0.25(6.4)	0.64(16.2)	0.63(16.0)	
1/2	6	-S-FJ8MJ6	1.88(47.7)	0.90(22.9)	0.87(22.2)	0.87(22.0)	0.19(4.8)	0.60(15.3)	0.55(14.0)	
1/2	10	-S-FJ8MJ10	1.93(48.9)	0.90(22.9)	0.87(22.2)	0.87(22.0)	0.31(7.9)	0.68(17.2)	0.75(19.0)	
1/2	12	-S-FJ8MJ12	2.02(51.4)	0.90(22.9)	0.87(22.2)	0.87(22.0)	0.37(9.5)	0.90(22.8)	0.87(22.0)	
3/4	12	-S-FJ12MJ12	2.13(54.2)	0.96(24.4)	1.13(28.6)	1.06(27.0)	0.37(9.5)	0.90(22.8)	0.87(22.0)	
3/4	16	-S-FJ12MJ16	2.12(53.9)	0.96(24.4)	1.13(28.6)	1.06(27.0)	0.50(12.7)	0.96(24.4)	0.98(25.0)	
3/4	18	-S-FJ12MJ18	2.11(53.6)	0.96(24.4)	1.13(28.6)	1.06(27.0)	0.59(15.1)	0.96(24.4)	1.18(30.0)	
1	25	-S-FJ16MJ25	2.65(67.4)	1.23(31.2)	1.50(38.1)	1.38(35.0)	0.86(21.8)	1.23(31.3)	1.50(38.0)	

公制 Tube管			英制 Tube管							
T-Tube 管外径 (mm)	Tx-Tube 管外径 (in.)	基本 订购号	尺寸, mm (in.)							
			L	C	G	F	E	Cx	Gx	
4	1/8	-S-MJ4FJ2	36.5(1.44)	13.7(0.54)	12.0(0.47)	2.4(0.09)	2.4(0.09)	12.7(0.50)	11.1(0.44)	
6	1/8	-S-MJ6FJ2	38.5(1.52)	15.3(0.60)	14.0(0.55)	14.0(0.55)	2.4(0.09)	12.7(0.50)	11.1(0.44)	
8	1/4	-S-MJ8FJ4	42.3(1.67)	16.2(0.64)	16.0(0.63)	15.0(0.59)	4.8(0.19)	15.2(0.60)	14.3(0.56)	
10	1/8	-S-MJ10FJ2	41.8(1.65)	17.2(0.68)	19.0(0.75)	18.0(0.71)	2.4(0.09)	12.7(0.50)	11.1(0.44)	
10	1/4	-S-MJ10FJ4	44.5(1.75)	17.2(0.68)	19.0(0.75)	18.0(0.71)	4.8(0.19)	15.2(0.60)	14.3(0.56)	
10	5/16	-S-MJ10FJ5	45.1(1.78)	17.2(0.68)	19.0(0.75)	18.0(0.71)	6.4(0.25)	16.2(0.64)	15.9(0.63)	
10	3/8	-S-MJ10FJ6	45.9(1.81)	17.2(0.68)	19.0(0.75)	18.0(0.71)	7.1(0.28)	16.8(0.66)	17.5(0.69)	
12	5/16	-S-MJ12FJ5	47.8(1.88)	22.8(0.90)	22.0(0.87)	22.0(0.87)	6.4(0.25)	16.2(0.64)	15.9(0.63)	
12	3/8	-S-MJ12FJ6	48.4(1.91)	22.8(0.90)	22.0(0.87)	22.0(0.87)	7.1(0.28)	16.8(0.66)	17.5(0.69)	
15	1/2	-S-MJ15FJ8	52.0(0.25)	24.4(0.96)	25.0(0.98)	24.0(0.94)	10.4(0.41)	22.9(0.90)	22.2(0.87)	
16	5/8	-S-MJ16FJ10	52.0(0.25)	24.4(0.96)	25.0(0.98)	24.0(0.94)	12.7(0.50)	24.4(0.96)	25.4(1.00)	
20	1/2	-S-MJ20FJ8	55.0(2.17)	26.0(1.02)	32.0(1.26)	30.0(1.18)	10.4(0.41)	22.9(0.90)	22.2(0.87)	

▶ 卡套直通变径接头

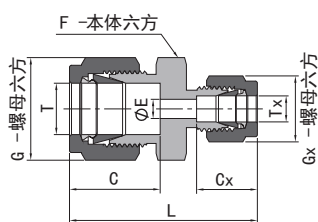

英制 Tube管									
T-Tube 管外径 (in.)	Tx-Tube 管外径 (in.)	基本 订购号	尺寸, in. (mm)						
			L	C	G	F	E	Cx	Gx
1/8	1/16	-S-FJ2FJ1	1.22(31.0)	0.50(12.7)	0.44(11.1)	0.44(11.1)	0.05(1.3)	0.34(8.6)	0.31(7.9)
3/16	1/16	-S-FJ3FJ1	1.27(32.3)	0.54(13.7)	0.50(12.7)	0.44(11.1)	0.05(1.3)	0.34(8.6)	0.31(7.9)
3/16	1/8	-S-FJ3FJ2	1.44(36.6)	0.54(13.7)	0.50(12.7)	0.44(11.1)	0.09(2.3)	0.50(12.7)	0.44(11.1)
1/4	1/16	-S-FJ4FJ1	1.35(34.3)	0.60(15.2)	0.56(14.3)	0.50(12.7)	0.05(1.3)	0.34(8.6)	0.31(7.9)
1/4	1/8	-S-FJ4FJ2	1.52(38.6)	0.60(15.2)	0.56(14.3)	0.50(12.7)	0.09(2.3)	0.50(12.7)	0.44(11.1)
1/4	3/16	-S-FJ4FJ3	1.55(39.4)	0.60(15.2)	0.56(14.3)	0.50(12.7)	0.12(3.0)	0.54(13.7)	0.50(12.7)
5/16	1/8	-S-FJ5FJ2	1.56(39.6)	0.64(16.2)	0.63(15.9)	0.56(14.3)	0.09(2.3)	0.50(12.7)	0.44(11.1)
5/16	1/4	-S-FJ5FJ4	1.66(42.2)	0.64(16.2)	0.63(15.9)	0.56(14.3)	0.19(4.8)	0.60(15.2)	0.56(14.3)
3/8	1/16	-S-FJ6FJ1	1.44(36.6)	0.66(16.8)	0.69(17.5)	0.63(15.9)	0.05(1.3)	0.34(8.6)	0.31(7.9)
3/8	1/8	-S-FJ6FJ2	1.61(40.9)	0.66(16.8)	0.69(17.5)	0.63(15.9)	0.09(2.3)	0.50(12.7)	0.44(11.1)
3/8	1/4	-S-FJ6FJ4	1.70(43.2)	0.66(16.8)	0.69(17.5)	0.63(15.9)	0.19(4.8)	0.60(15.2)	0.56(14.3)
3/8	5/16	-S-FJ6FJ5	1.74(44.2)	0.66(16.8)	0.69(17.5)	0.63(15.9)	0.25(6.4)	0.64(16.2)	0.63(15.9)
1/2	1/8	-S-FJ8FJ2	1.78(45.2)	0.90(22.8)	0.87(22.2)	0.81(20.6)	0.09(2.3)	0.50(12.7)	0.44(11.1)
1/2	1/4	-S-FJ8FJ4	1.85(47.0)	0.90(22.8)	0.87(22.2)	0.81(20.6)	0.19(4.8)	0.60(15.2)	0.56(14.3)
1/2	3/8	-S-FJ8FJ6	1.91(48.5)	0.90(22.8)	0.87(22.2)	0.81(20.6)	0.28(7.1)	0.66(16.8)	0.69(17.5)
5/8	3/8	-S-FJ10FJ6	1.94(49.3)	0.96(24.4)	1.00(25.4)	0.94(23.9)	0.28(7.1)	0.66(16.8)	0.69(17.5)
5/8	1/2	-S-FJ10FJ8	2.05(52.1)	0.96(24.4)	1.00(25.4)	0.94(23.9)	0.41(10.4)	0.90(22.8)	0.87(22.2)
3/4	1/4	-S-FJ12FJ4	1.94(49.3)	0.96(24.4)	1.13(28.6)	1.06(27.0)	0.19(4.8)	0.60(15.2)	0.56(14.3)
3/4	3/8	-S-FJ12FJ6	2.00(50.8)	0.96(24.4)	1.13(28.6)	1.06(27.0)	0.28(7.1)	0.66(16.8)	0.69(17.5)
3/4	1/2	-S-FJ12FJ8	2.11(53.6)	0.96(24.4)	1.13(28.6)	1.06(27.0)	0.41(10.4)	0.90(22.8)	0.87(22.2)
3/4	5/8	-S-FJ12FJ10	2.11(53.6)	0.96(24.4)	1.13(28.6)	1.06(27.0)	0.50(12.7)	0.96(24.4)	1.00(25.4)
1	1/2	-S-FJ16FJ8	2.38(60.5)	1.23(31.2)	1.50(38.1)	1.37(34.9)	0.41(10.4)	0.90(22.8)	0.87(22.2)
1	3/4	-S-FJ16FJ12	2.38(60.5)	1.23(31.2)	1.50(38.1)	1.37(34.9)	0.62(15.7)	0.96(24.4)	1.13(28.6)

▶ 卡套直通变径接头

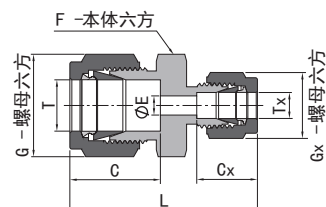

公制 Tube管									
T-Tube 管外径 (mm)	Tx-Tube 管外径 (mm)	基本 订购号	尺寸, mm (in.)						
			L	C	G	F	E	Cx	Gx
3	2	-S-MJ3MJ2	35.3(1.39)	12.9(0.51)	12.0(0.47)	12.0(0.47)	1.7(0.07)	12.9(0.51)	12.0(0.47)
6	2	-S-MJ6MJ2	38.6(1.52)	15.3(0.60)	14.0(0.55)	14.0(0.55)	1.7(0.07)	12.9(0.51)	12.0(0.47)
6	3	-S-MJ6MJ3	38.6(1.52)	15.3(0.60)	14.0(0.55)	14.0(0.55)	2.4(0.09)	12.9(0.51)	12.0(0.47)
6	4	-S-MJ6MJ4	39.4(1.55)	15.3(0.60)	14.0(0.55)	14.0(0.55)	2.4(0.09)	13.7(0.54)	12.0(0.47)
8	6	-S-MJ8MJ6	42.3(1.67)	16.3(0.64)	16.0(0.63)	15.0(0.59)	4.8(0.19)	15.3(0.60)	14.0(0.55)
10	6	-S-MJ10MJ6	44.5(1.75)	17.2(0.68)	19.0(0.75)	18.0(0.71)	4.8(0.19)	15.3(0.60)	14.0(0.55)
10	8	-S-MJ10MJ8	45.1(1.78)	17.2(0.68)	19.0(0.75)	18.0(0.71)	6.4(0.25)	16.3(0.64)	16.0(0.63)
12	6	-S-MJ12MJ6	47.0(1.85)	22.8(0.90)	22.0(0.87)	22.0(0.87)	4.8(0.19)	15.3(0.60)	14.0(0.55)
12	8	-S-MJ12MJ8	47.8(1.88)	22.8(0.90)	22.0(0.87)	22.0(0.87)	6.4(0.25)	16.3(0.64)	16.0(0.63)
12	10	-S-MJ12MJ10	48.7(1.92)	22.8(0.90)	22.0(0.87)	22.0(0.87)	7.9(0.31)	17.2(0.68)	19.0(0.75)
16	10	-S-MJ16MJ10	49.5(1.95)	24.4(0.96)	25.0(0.98)	24.0(0.94)	7.9(0.31)	17.2(0.68)	19.0(0.75)
16	12	-S-MJ16MJ12	52.0(2.05)	24.4(0.96)	25.0(0.98)	24.0(0.94)	9.5(0.37)	22.8(0.90)	22.0(0.87)
18	12	-S-MJ18MJ12	53.5(2.11)	24.4(0.96)	30.0(1.18)	27.0(1.06)	9.5(0.37)	22.8(0.90)	22.0(0.87)
25	18	-S-MJ25MJ18	61.0(2.40)	31.3(1.23)	38.0(1.50)	35.0(1.38)	15.1(0.59)	24.4(0.96)	30.0(1.18)
25	20	-S-MJ25MJ20	62.3(2.45)	31.3(1.23)	38.0(1.50)	35.0(1.38)	15.9(0.63)	26.0(1.02)	32.0(1.26)
30	18	-S-MJ30MJ18	75.4(2.97)	39.6(1.56)	50.0(1.97)	46.0(1.81)	15.1(0.59)	24.4(0.96)	30.0(1.18)
30	20	-S-MJ30MJ20	75.4(2.97)	39.6(1.56)	50.0(1.97)	46.0(1.81)	15.9(0.63)	26.0(1.02)	32.0(1.26)
30	25	-S-MJ30MJ25	80.1(3.15)	39.6(1.56)	50.0(1.97)	46.0(1.81)	21.8(0.86)	31.3(1.23)	38.0(1.50)
32	18	-S-MJ32MJ18	77.8(3.06)	42.0(1.65)	50.0(1.97)	46.0(1.81)	15.1(0.59)	24.4(0.96)	30.0(1.18)
32	20	-S-MJ32MJ20	77.8(3.06)	42.0(1.65)	50.0(1.97)	46.0(1.81)	15.9(0.63)	26.0(1.02)	32.0(1.26)
32	25	-S-MJ32MJ25	82.3(3.24)	42.0(1.65)	50.0(1.97)	46.0(1.81)	21.8(0.86)	31.3(1.23)	38.0(1.50)
38	20	-S-MJ38MJ20	87.5(3.44)	49.4(1.94)	60.0(2.36)	55.0(2.17)	15.9(0.63)	26.0(1.02)	32.0(1.26)
38	25	-S-MJ38MJ25	92.0(3.62)	49.4(1.94)	60.0(2.36)	55.0(2.17)	21.8(0.86)	31.3(1.23)	38.0(1.50)
38	30	-S-MJ38MJ30	104.6(4.12)	49.4(1.94)	60.0(2.36)	55.0(2.17)	26.2(1.03)	39.6(1.56)	50.0(1.97)

► 柱端接头

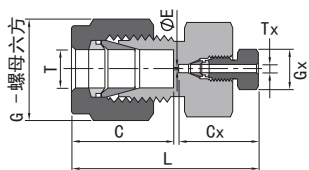

英制 Tube管									
T-Tube 管外径 (in.)	Tx-Tube 管外径 (in.)	基本 订购号	尺寸, in. (mm)						死区
			L	C	Cx	E	G	Gx	
1/4	1/16	-S-FJ4NFJ1-LV	1.24(31.5)	0.60(15.2)	0.61(15.5)	0.01(0.3)	0.56(14.3)	0.25(6.4)	$6.8^5 \times 10^{-3}$ cm
3/8	1/16	-S-FJ6NFJ1-LV	1.30(33.0)	0.66(16.8)	0.61(15.5)	0.01(0.3)	0.69(17.5)	0.25(6.4)	$6.8^5 \times 10^{-3}$ cm

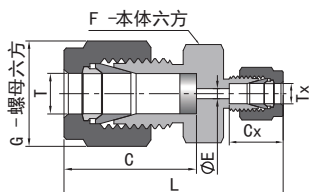

英制 Tube管									
T-Tube 管外径 (in.)	Tx-Tube 管外径 (in.)	基本 订购号	尺寸, in. (mm)						死区
			L	C	Cx	G	F	E	
1/8	1/16	-S-FJ2FJ1-SN7-LV	1.22(31.0)	0.72(18.3)	0.34(8.6)	0.44(11.1)	0.44(11.1)	0.05(1.3)	$5.4^3 \times 10^{-3}$ cm
1/4	1/16	-S-FJ4FJ1-SN7-LV	1.35(34.3)	0.82(20.8)	0.34(8.6)	0.56(14.3)	0.50(12.7)	0.05(1.3)	$6.7^3 \times 10^{-3}$ cm
3/8	1/16	-S-FJ6FJ1-SN7-LV	1.44(36.6)	0.91(23.1)	0.34(8.6)	0.69(17.5)	0.63(15.9)	0.05(1.3)	$6.5^3 \times 10^{-3}$ cm

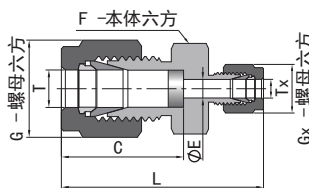

英制 Tube管									
T-Tube 管外径 (in.)	Tx-Tube 管外径 (in.)	基本 订购号	尺寸, in. (mm)						死区
			L	C	G	Gx	F	E	
1/8	1/16	-S-FJ2TFJ1-SN7-ZV	1.22(31.0)	0.72(18.3)	0.44(11.1)	0.31(7.9)	0.44(11.1)	0.07(1.7)	0
1/4	1/16	-S-FJ4TFJ1-SN7-ZV	1.35(34.3)	0.82(20.8)	0.56(14.3)	0.31(7.9)	0.50(12.7)	0.07(1.7)	0
3/8	1/16	-S-FJ6TFJ1-SN7-ZV	1.44(36.6)	0.91(23.1)	0.69(17.5)	0.31(7.9)	0.63(15.9)	0.07(1.7)	0
1/2	1/16	-S-FJ8TFJ1-SN7-ZV	1.58(40.1)	1.04(26.4)	0.87(22.2)	0.31(7.9)	0.81(20.6)	0.07(1.7)	0

SN7 表示不锈钢烧结块公称孔尺寸为7 um, 可提供其他公称孔尺寸, 不锈钢烧结块松散安装以便于拆卸和更换。

▶ 卡套直通穿板接头

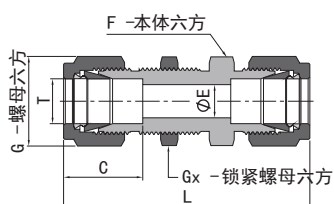

英制 Tube 管									
Tx-Tube 管外径 (in.)	基本 订购号	尺寸, in. (mm)						面板孔 尺寸 in. (mm)	最大面板 厚度 in. (mm)
		L	C	E	G	F	Gx		
1/16	-S-BFJ1	1.24(31.5)	0.34(8.6)	0.05(1.3)	0.31(7.9)	0.31(7.9)	0.31(7.9)	0.20(5.2)	0.12(3.0)
1/8	-S-BFJ2	2.02(51.3)	0.50(12.7)	0.09(2.3)	0.44(11.1)	0.50(12.7)	0.50(12.7)	0.33(8.3)	0.50(12.7)
3/16	-S-BFJ3	2.11(53.6)	0.54(13.7)	0.12(3.0)	0.50(12.7)	0.56(14.3)	0.56(14.3)	0.39(9.9)	0.50(12.7)
1/4	-S-BFJ4	2.27(57.7)	0.60(15.2)	0.19(4.8)	0.56(14.3)	0.63(15.9)	0.63(15.9)	0.45(11.5)	0.40(10.2)
5/16	-S-BFJ5	2.39(60.7)	0.64(16.3)	0.25(6.4)	0.63(15.9)	0.69(17.5)	0.69(17.5)	0.52(13.1)	0.44(11.2)
3/8	-S-BF6	2.45(62.2)	0.66(16.8)	0.28(7.1)	0.69(17.5)	0.75(19.1)	0.75(19.1)	0.58(14.7)	0.44(11.2)
1/2	-S-BF8	2.80(71.1)	0.90(22.9)	0.41(10.4)	0.87(22.2)	0.94(23.8)	0.94(23.8)	0.76(19.4)	0.50(12.7)
5/8	-S-BF10	2.86(72.6)	0.96(24.4)	0.50(12.7)	1.00(25.4)	1.06(27.0)	1.06(27.0)	0.89(22.6)	0.50(12.7)
3/4	-S-BF12	3.11(79.0)	0.96(24.4)	0.62(15.7)	1.13(28.6)	1.19(30.2)	1.19(30.2)	1.02(25.8)	0.66(16.8)
7/8	-S-BF14	3.35(85.2)	1.02(25.9)	0.72(18.3)	1.25(31.8)	1.38(34.9)	1.38(34.9)	1.14(29.0)	0.75(19.1)
1	-S-BF16	3.77(95.8)	1.23(31.2)	0.88(22.4)	1.50(38.1)	1.63(41.3)	1.63(41.3)	1.33(33.7)	0.75(19.1)
1 1/4	-S-BF20	4.85(123.2)	1.62(41.1)	1.09(27.8)	1.87(47.6)	1.87(47.6)	1.87(47.6)	1.64(41.7)	0.75(19.1)
1 1/2	-S-BF24	5.48(139.2)	1.97(50.0)	1.34(34.0)	2.25(57.2)	2.25(57.2)	2.25(57.2)	1.95(49.6)	0.75(19.1)

公制 Tube 管									
Tx-Tube 管外径 (mm)	基本 订购号	尺寸, mm (in.)						面板孔 尺寸 mm (in.)	最大面板 厚度 mm (in.)
		L	C	E	G	F	Gx		
3	-S-BMJ3	51.3(2.02)	12.9(0.51)	2.4(0.09)	12.0(0.47)	14.0(0.55)	14.0(0.55)	8.3(0.33)	12.7(0.50)
4	-S-BMJ4	53.6(2.11)	13.7(0.54)	2.4(0.09)	12.0(0.47)	14.0(0.55)	14.0(0.55)	9.9(0.39)	12.7(0.50)
6	-S-BMJ6	57.7(2.27)	15.3(0.60)	4.8(0.19)	14.0(0.55)	16.0(0.63)	16.0(0.63)	11.5(0.45)	10.2(0.40)
8	-S-BMJ8	61.0(2.40)	16.2(0.64)	6.4(0.25)	16.0(0.63)	18.0(0.71)	18.0(0.71)	13.1(0.52)	11.2(0.44)
10	-S-BMJ10	63.7(2.51)	17.2(0.68)	7.9(0.31)	19.0(0.75)	22.0(0.87)	22.0(0.87)	16.3(0.64)	11.2(0.44)
12	-S-BMJ12	71.0(2.80)	22.8(0.90)	9.5(0.37)	22.0(0.87)	24.0(0.94)	24.0(0.94)	19.5(0.77)	12.7(0.50)
14	-S-BMJ14	72.5(2.85)	24.4(0.96)	11.1(0.44)	25.0(0.98)	27.0(1.06)	27.0(1.06)	22.5(0.89)	12.7(0.50)
15	-S-BMJ15	72.5(2.85)	24.4(0.96)	11.9(0.47)	25.0(0.98)	27.0(1.06)	27.0(1.06)	22.8(0.90)	12.7(0.50)
16	-S-BMJ16	72.5(2.85)	24.4(0.96)	12.7(0.50)	25.0(0.98)	27.0(1.06)	27.0(1.06)	22.8(0.90)	12.7(0.50)
18	-S-BMJ18	78.9(3.11)	24.4(0.96)	15.1(0.59)	30.0(1.18)	30.0(1.18)	30.0(1.18)	26.0(1.02)	16.8(0.66)
20	-S-BMJ20	84.5(3.33)	26.0(1.02)	15.9(0.63)	32.0(1.26)	35.0(1.38)	35.0(1.38)	29.0(1.14)	19.0(0.75)
25	-S-BMJ25	96.0(3.78)	31.3(1.23)	21.8(0.86)	38.0(1.5)	41.0(1.61)	41.0(1.61)	34.0(1.34)	19.0(0.75)
30	-S-BMJ30	124.0(4.88)	39.6(1.56)	26.2(1.03)	50.0(1.97)	50.0(1.97)	50.0(1.97)	40.5(1.59)	19.0(0.75)
32	-S-BMJ32	128.0(5.04)	42.0(1.65)	28.6(1.13)	50.0(1.97)	50.0(1.97)	50.0(1.97)	42.5(1.67)	19.0(0.75)
38	-S-BMJ38	145.0(5.71)	49.4(1.94)	33.7(1.33)	60.0(2.36)	60.0(2.36)	60.0(2.36)	50.5(1.99)	19.0(0.75)

► 卡套直通穿板变径接头

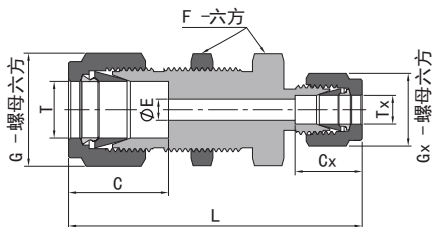

英制 Tube 管											
T-Tube 管外径 (in.)	Tx-Tube 管外径 (in.)	基本 订购号	尺寸, in. (mm)							面板孔 尺寸 in. (mm)	最大面板 厚度 in. (mm)
			L	C	E	G	F	Cx	Gx		
1/4	1/8	-S-BFJ4FJ2	2.17(55.1)	0.60(15.2)	0.09(2.3)	0.56(14.3)	0.63(15.9)	0.50(12.7)	0.44(11.1)	0.45(11.5)	0.40(10.2)
3/8	1/4	-S-BFJ6FJ4	2.39(60.7)	0.66(16.8)	0.19(4.8)	0.69(17.5)	0.75(19.1)	0.60(15.2)	0.56(14.3)	0.58(14.7)	0.44(11.2)
1/2	1/4	-S-BFJ8FJ4	2.63(66.8)	0.90(22.9)	0.19(4.8)	0.87(22.2)	0.94(23.8)	0.60(15.2)	0.56(14.3)	0.76(19.4)	0.50(12.7)

公制 Tube 管											
T-Tube 管外径 (mm)	Tx-Tube 管外径 (mm)	基本 订购号	尺寸, mm (in.)							面板孔 尺寸 mm (in.)	最大面板 厚度 mm (in.)
			L	C	E	G	F	Cx	Gx		
6	3	-S-BMJ6MJ3	55.1(2.17)	15.3(0.60)	2.4(0.09)	14.0(0.55)	16.0(0.63)	12.9(0.51)	12.0(0.47)	11.5(0.45)	10.2(0.40)
8	6	-S-BMJ8MJ6	60.1(2.37)	16.2(0.64)	4.8(0.19)	16.0(0.63)	18.0(0.71)	15.3(0.60)	14.0(0.55)	13.1(0.52)	11.2(0.44)
12	8	-S-BMJ12MJ8	67.6(2.66)	22.8(0.90)	6.4(0.25)	22.0(0.87)	24.0(0.94)	16.2(0.64)	16.0(0.63)	19.5(0.77)	12.7(0.50)

► 卡套直通穿板转换接头

英制 Tube 管										公制 Tube 管	
T-Tube 管外径 (in.)	Tx-Tube 管外径 (mm)	基本 订购号	尺寸, in. (mm)							面板孔 尺寸 in. (mm)	最大面板 厚度 in. (mm)
			L	C	E	G	F	Cx	Gx		
1/4	6	-S-BFJ4MJ6	2.27(57.7)	0.60(15.2)	0.19(4.8)	0.56(14.3)	0.63(15.9)	0.60(15.3)	0.55(14.0)	0.45(11.5)	0.40(10.2)

公制 Tube 管										英制 Tube 管	
T-Tube 管外径 (mm)	Tx-Tube 管外径 (in.)	基本 订购号	尺寸, mm (in.)							面板孔 尺寸 mm (in.)	最大面板 厚度 mm (in.)
			L	C	E	G	F	Cx	Gx		
6	1/8	-S-BMJ6FJ2	55.1(2.17)	15.3(0.60)	2.3(0.09)	14.0(0.55)	16.0(0.63)	12.7(0.50)	11.0(0.43)	11.5(0.45)	10.2(0.40)
6	1/4	-S-BMJ6FJ4	57.7(2.27)	15.3(0.60)	4.8(0.19)	14.0(0.55)	16.0(0.63)	15.2(0.60)	14.3(0.56)	11.5(0.45)	10.2(0.40)

▶ 卡套直通穿舱接头

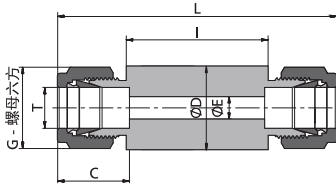

英制 Tube 管							
T-Tube 管外径 (in.)	基本订购号	尺寸, in.(mm)					
		L	C	E	G	D	I
1/8	-S-BFJ2-OD12	3.16(80.2)	0.50(12.7)	0.09(2.3)	0.44(11.1)	0.47(12.0)	1.97(50.0)
3/16	-S-BFJ3-OD12	3.24(82.2)	0.54(13.7)	0.12(3.0)	0.50(12.7)	0.47(12.0)	1.97(50.0)
1/4	-S-BFJ4-OD14	3.35(85.2)	0.60(15.2)	0.19(4.8)	0.56(14.3)	0.55(14.0)	1.97(50.0)
5/16	-S-BFJ5-OD16	3.43(87.2)	0.64(16.2)	0.25(6.4)	0.63(15.9)	0.63(16.0)	1.97(50.0)
3/8	-S-BFJ6-OD19	3.49(88.6)	0.66(16.8)	0.28(7.1)	0.69(17.5)	0.75(19.0)	1.97(50.0)
1/2	-S-BFJ8-OD23	3.69(93.8)	0.90(22.9)	0.41(10.4)	0.87(22.2)	0.91(23.0)	1.97(50.0)
5/8	-S-BFJ10-OD28	3.69(93.6)	0.96(24.4)	0.50(12.7)	1.00(25.4)	1.10(28.0)	1.97(50.0)
3/4	-S-BFJ12-OD32	3.72(94.4)	0.96(24.4)	0.62(15.7)	1.13(28.6)	1.26(32.0)	1.97(50.0)
7/8	-S-BFJ14-OD32	3.72(94.4)	1.02(25.9)	0.72(18.3)	1.25(31.8)	1.26(32.0)	1.97(50.0)
1	-S-BFJ16-OD35	4.06(103.2)	1.23(31.2)	0.88(22.4)	1.50(38.1)	1.38(35.0)	1.97(50.0)
1-1/4	-S-BFJ20-OD50	5.05(128.2)	1.62(41.1)	1.09(27.7)	1.87(47.6)	1.97(50.0)	1.97(50.0)
1-1/2	-S-BFJ24-OD55	5.54(140.8)	1.97(50.0)	1.34(34.0)	2.25(57.2)	2.17(55.0)	1.97(50.0)
2	-S-BFJ32-OD80	6.93(176.0)	2.67(67.8)	1.81(46.0)	3.00(76.2)	3.15(80.0)	1.97(50.0)

公制 Tube 管							
T-Tube 管外径 (mm)	基本订购号	尺寸, mm.(in)					
		L	C	E	G	D	I
3	-S-MJ3-OD12	80.8(3.18)	12.9(0.51)	2.4(0.09)	12.0(0.47)	12.0(0.47)	50.0(1.97)
4	-S-MJ4-OD12	82.4(3.24)	13.7(0.54)	2.4(0.09)	12.0(0.47)	12.0(0.47)	50.0(1.97)
6	-S-MJ6-OD12	86.0(3.39)	15.3(0.60)	4.8(0.19)	14.0(0.55)	12.0(0.47)	50.0(1.97)
8	-S-MJ8-OD16	87.4(3.44)	16.2(0.64)	6.4(0.25)	16.0(0.63)	16.0(0.63)	50.0(1.97)
10	-S-MJ10-OD19	89.0(3.50)	17.2(0.68)	7.9(0.31)	19.0(0.75)	19.0(0.75)	50.0(1.97)
12	-S-MJ12-OD23	94.2(3.71)	22.8(0.90)	9.5(0.37)	22.0(0.87)	23.0(0.91)	50.0(1.97)
15	-S-MJ15-OD25	93.8(3.69)	24.4(0.96)	11.9(0.47)	25.0(0.98)	25.0(0.98)	50.0(1.97)
16	-S-MJ16-OD28	94.4(3.72)	24.4(0.96)	12.7(0.50)	25.0(0.98)	28.0(1.10)	50.0(1.97)
18	-S-MJ18-OD28	94.0(3.70)	24.4(0.96)	15.1(0.59)	30.0(1.18)	28.0(1.10)	50.0(1.97)
20	-S-MJ20-OD32	94.0(3.70)	26.0(1.02)	15.9(0.63)	32.0(1.26)	32.0(1.26)	50.0(1.97)
22	-S-MJ22-OD32	94.0(3.70)	26.0(1.02)	18.3(0.72)	32.0(1.26)	32.0(1.26)	50.0(1.97)
25	-S-MJ25-OD38	103.2(4.06)	31.3(1.23)	21.8(0.86)	38.0(1.50)	38.0(1.50)	50.0(1.97)
28	-S-MJ28-OD45	123.2(4.85)	36.6(1.44)	21.8(0.86)	46.0(1.81)	45.0(1.77)	50.0(1.97)
32	-S-MJ32-OD50	133.2(5.24)	42.0(1.65)	28.6(1.13)	50.0(1.97)	50.0(1.97)	50.0(1.97)
38	-S-MJ38-OD60	146.2(5.76)	49.4(1.94)	33.7(1.33)	60.0(2.36)	60.0(2.36)	50.0(1.97)

◆ 如需非标长度可在基本订购号末端尾缀“-**”，“**”代表公制长度，例如：-S-BMJ12-OD23-100

▶ 穿板锁紧螺母

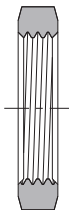

英制 Tube 管	
T-Tube 管外径 (in.)	基本订购号
1/16	-BN-FJ1
1/8	-BN-FJ2
3/16	-BN-FJ3
1/4	-BN-FJ4
5/16	-BN-FJ5
3/8	-BN-FJ6
1/2	-BN-FJ8
5/8	-BN-FJ10
3/4	-BN-FJ12
7/8	-BN-FJ14
1	-BN-FJ16
1 1/4	-BN-FJ20
1 1/2	-BN-FJ24

公制 Tube 管	
T-Tube 管外径 (mm)	基本订购号
3	-BN-MJ3
4	-BN-MJ4
6	-BN-MJ6
8	-BN-MJ8
10	-BN-MJ10
12	-BN-MJ12
14	-BN-MJ14
18	-BN-MJ18
20	-BN-MJ20
22	-BN-MJ22
25	-BN-MJ25
28	-BN-MJ28
30	-BN-MJ30
32	-BN-MJ32
38	-BN-MJ38

▶ 卡套阳螺纹弯头

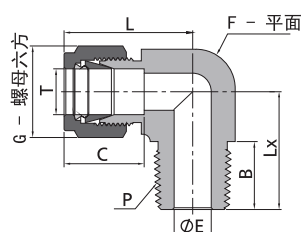

◆ 尺寸“E”为最小公称孔口,此孔口在管螺纹端、直螺纹端可能会更大。

英制 Tube管			NPT 螺纹						
T-Tube 管外径 (in.)	P-NPT 尺寸	基本 订购号	尺寸, in. (mm)						
			L	C	G	F	E	B	Lx
1/16	1/16	-L-FJ1N1	0.75(19.1)	0.34(8.6)	0.31(7.9)	0.44(11.1)	0.05(1.3)	0.38(9.7)	0.70(17.8)
1/16	1/8	-L-FJ1N2	0.75(19.1)	0.34(8.6)	0.31(7.9)	0.44(11.1)	0.05(1.3)	0.38(9.7)	0.70(17.8)
1/8	1/16	-L-FJ2N1	0.93(23.6)	0.50(12.7)	0.44(11.1)	0.44(11.1)	0.09(2.4)	0.38(9.7)	0.70(17.8)
1/8	1/8	-L-FJ2N2	0.93(23.6)	0.50(12.7)	0.44(11.1)	0.44(11.1)	0.09(2.4)	0.38(9.7)	0.70(17.8)
1/8	1/4	-L-FJ2N4	0.97(24.6)	0.50(12.7)	0.44(11.1)	0.50(12.7)	0.09(2.3)	0.56(14.2)	0.92(23.4)
3/16	1/8	-L-FJ3N2	1.00(25.4)	0.54(13.7)	0.56(14.3)	0.50(12.7)	0.12(3.0)	0.38(9.7)	0.74(18.8)
3/16	1/4	-L-FJ3N4	1.00(25.4)	0.54(13.7)	0.63(15.9)	0.50(12.7)	0.09(2.3)	0.56(14.2)	0.92(23.4)
1/4	1/16	-L-FJ4N1	1.06(26.9)	0.60(15.2)	0.63(15.9)	0.50(12.7)	0.19(4.8)	0.38(9.7)	0.74(18.8)
1/4	1/8	-L-FJ4N2	1.06(26.9)	0.60(15.2)	0.69(17.5)	0.50(12.7)	0.05(1.3)	0.38(9.7)	0.74(18.8)
1/4	1/4	-L-FJ4N4	1.06(26.9)	0.60(15.2)	0.69(17.5)	0.50(12.7)	0.09(2.3)	0.56(14.2)	0.92(23.4)
1/4	3/8	-L-FJ4N6	1.17(29.7)	0.60(15.2)	0.69(17.5)	0.69(17.5)	0.19(4.8)	0.56(14.2)	1.03(26.2)
1/4	1/2	-L-FJ4N8	1.25(31.8)	0.60(15.2)	0.69(17.5)	0.81(20.6)	0.25(6.4)	0.75(19.1)	1.30(33.0)
5/16	1/8	-L-FJ5N2	1.13(28.7)	0.64(16.3)	0.87(22.2)	0.56(14.3)	0.09(2.3)	0.38(9.7)	0.78(19.8)
5/16	1/4	-L-FJ5N4	1.13(28.7)	0.64(16.3)	0.87(22.2)	0.56(14.3)	0.19(4.8)	0.56(14.2)	0.96(24.4)
5/16	3/8	-L-FJ5N6	1.20(30.5)	0.64(16.3)	0.87(22.2)	0.69(17.5)	0.28(7.1)	0.56(14.2)	1.03(26.2)
3/8	1/8	-L-FJ6N2	1.20(30.5)	0.66(16.8)	0.69(17.5)	0.63(15.9)	0.28(7.1)	0.38(9.7)	0.82(20.8)
3/8	1/4	-L-FJ6N4	1.20(30.5)	0.66(16.8)	0.69(17.5)	0.63(15.9)	0.28(7.1)	0.56(14.2)	1.00(25.4)
3/8	3/8	-L-FJ6N6	1.23(31.2)	0.66(16.8)	0.69(17.5)	0.69(17.5)	0.28(7.1)	0.56(14.2)	1.03(26.2)
3/8	1/2	-L-FJ6N8	1.31(33.3)	0.66(16.8)	0.69(17.5)	0.81(20.6)	0.28(7.1)	0.75(19.1)	1.30(33.0)
3/8	3/4	-L-FJ6N12	1.46(37.1)	0.66(16.8)	0.69(17.5)	1.06(27.0)	0.28(7.1)	0.75(19.1)	1.45(36.8)
1/2	1/4	-L-FJ8N4	1.42(36.1)	0.90(22.9)	0.87(22.2)	0.81(20.6)	0.28(7.1)	0.56(14.2)	1.11(28.2)
1/2	3/8	-L-FJ8N6	1.42(36.1)	0.90(22.9)	0.87(22.2)	0.81(20.6)	0.38(9.7)	0.56(14.2)	1.11(28.2)
1/2	1/2	-L-FJ8N8	1.42(36.1)	0.90(22.9)	0.87(22.2)	0.81(20.6)	0.41(10.4)	0.75(19.1)	1.30(33.0)
1/2	3/4	-L-FJ8N12	1.57(39.9)	0.90(22.8)	0.87(22.2)	1.06(27.0)	0.41(10.4)	0.75(19.1)	1.45(36.8)
5/8	3/8	-L-FJ10N6	1.50(38.1)	0.96(24.4)	1.00(25.4)	0.94(23.8)	0.38(9.7)	0.56(14.2)	1.19(30.2)
5/8	1/2	-L-FJ10N8	1.50(38.1)	0.96(24.4)	1.00(25.4)	0.94(23.9)	0.47(11.9)	0.75(19.1)	1.38(35.1)
5/8	3/4	-L-FJ10N12	1.57(39.9)	0.96(24.4)	1.00(25.4)	1.06(27.0)	0.50(12.7)	0.75(19.1)	1.45(36.8)
3/4	1/2	-L-FJ12N8	1.57(39.9)	0.96(24.4)	1.13(28.6)	1.06(27.0)	0.47(11.9)	0.75(19.1)	1.45(36.8)
3/4	3/4	-L-FJ12N12	1.57(39.9)	0.96(24.4)	1.13(28.6)	1.06(27.0)	0.62(15.7)	0.75(19.1)	1.45(36.8)
7/8	3/4	-L-FJ14N12	1.76(44.7)	0.96(24.4)	1.25(31.8)	1.37(34.9)	0.62(15.7)	0.75(19.1)	1.64(41.7)
1	3/4	-L-FJ16N12	1.93(49.0)	1.23(31.2)	1.50(38.1)	1.37(34.9)	0.62(15.7)	0.75(19.1)	1.64(41.7)
1	1	-L-FJ16N16	1.93(49.0)	1.23(31.2)	1.50(38.1)	1.37(34.9)	0.88(22.4)	0.94(23.9)	1.83(46.5)
1 1/4	1 1/4	-L-FJ20N20	2.62(66.5)	1.62(41.1)	1.87(47.6)	1.69(42.9)	1.09(27.7)	0.94(23.9)	2.06(52.4)
1 1/2	1 1/2	-L-FJ24N24	3.07(78.0)	1.97(50.0)	2.25(57.2)	2.00(50.8)	1.34(34.0)	1.03(26.2)	2.38(60.5)

英制 Tube管			ISO 锥螺纹 (RT)						
T-Tube 管外径 (in.)	P-RT 尺寸	基本 订购号	尺寸, in. (mm)						
			L	C	G	F	E	B	Lx
1/8	1/8	-L-FJ2RT2	0.93(23.6)	0.50(12.7)	0.44(11.1)	0.44(11.1)	0.09(2.4)	0.38(9.7)	0.87(22.2)
1/8	1/4	-L-FJ2RT4	0.97(24.6)	0.50(12.7)	0.44(11.1)	0.50(12.7)	0.09(2.4)	0.56(14.2)	0.92(23.4)
1/4	1/8	-L-FJ4RT2	1.06(26.9)	0.60(15.2)	0.56(14.3)	0.50(12.7)	0.19(4.8)	0.38(9.7)	0.74(18.8)
1/4	1/4	-L-FJ4RT4	1.06(26.9)	0.60(15.2)	0.56(14.3)	0.50(12.7)	0.19(4.8)	0.56(14.2)	0.92(23.4)
1/4	3/8	-L-FJ4RT6	1.17(29.7)	0.60(15.2)	0.56(14.3)	0.50(12.7)	0.19(4.8)	0.56(14.2)	1.03(26.2)
1/4	1/2	-L-FJ4RT8	1.25(31.8)	0.60(15.2)	0.56(14.3)	0.50(12.7)	0.19(4.8)	0.75(19.1)	1.30(33.0)
5/16	1/4	-L-FJ5RT4	1.13(28.7)	0.64(16.3)	0.63(15.9)	0.56(14.3)	0.25(6.4)	0.56(14.2)	0.96(24.4)
3/8	1/8	-L-FJ6RT2	1.20(30.5)	0.66(16.8)	0.69(17.5)	0.63(15.9)	0.19(4.8)	0.38(9.7)	0.82(20.8)
3/8	1/4	-L-FJ6RT4	1.20(30.5)	0.66(16.8)	0.69(17.5)	0.63(15.9)	0.28(7.1)	0.56(14.2)	1.00(25.4)
3/8	3/8	-L-FJ6RT6	1.23(31.2)	0.66(16.8)	0.69(17.5)	0.69(17.5)	0.28(7.1)	0.56(14.2)	1.03(26.2)
1/2	3/8	-L-FJ8RT6	1.42(36.1)	0.90(22.9)	0.87(22.2)	0.81(20.6)	0.38(9.7)	0.56(14.2)	1.11(28.2)
1/2	1/2	-L-FJ8RT8	1.42(36.1)	0.90(22.9)	0.87(22.2)	0.81(20.6)	0.41(10.4)	0.75(19.1)	1.30(33.0)
3/4	1/2	-L-FJ12RT8	1.57(39.9)	0.96(24.4)	1.13(28.6)	1.06(27.0)	0.37(9.5)	0.75(19.1)	1.45(36.8)
1	1	-L-FJ16RT16	1.93(49.0)	1.23(31.2)	1.50(38.1)	1.37(34.9)	0.88(22.4)	0.94(23.9)	1.83(46.5)

▶ 卡套阳螺纹弯头

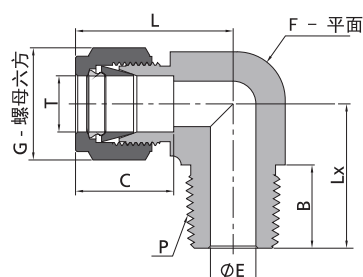

◆ 尺寸“E”为最小公称孔口,此孔口在管螺纹端、直螺纹端可能会更大。

英制 Tube 管				NPT 螺纹					
T-Tube 管外径 (in.)	P-NPT 尺寸	基本 订购号	尺寸, in. (mm)						
			L	C	G	F	E	B	Lx
3	1/8	-L-MJ3N2	23.6(0.93)	12.9(0.51)	12.0(0.47)	11.1(0.44)	2.4(0.09)	9.7(0.38)	17.8(0.70)
3	1/4	-L-MJ3N4	24.6(0.97)	12.9(0.51)	12.0(0.47)	12.7(0.50)	2.4(0.09)	14.2(0.56)	23.4(0.92)
4	1/8	-L-MJ4N2	25.4(1.00)	13.7(0.54)	12.0(0.47)	12.7(0.50)	2.4(0.09)	9.7(0.38)	18.8(0.74)
4	1/4	-L-MJ4N4	25.4(1.00)	13.7(0.54)	12.0(0.47)	12.7(0.50)	2.4(0.09)	14.2(0.56)	23.4(0.92)
6	1/8	-L-MJ6N2	27.0(1.06)	15.3(0.60)	14.0(0.55)	12.7(0.50)	4.8(0.19)	9.7(0.38)	18.8(0.74)
6	1/4	-L-MJ6N4	27.0(1.06)	15.3(0.60)	14.0(0.55)	12.7(0.50)	4.8(0.19)	14.2(0.56)	23.4(0.92)
6	3/8	-L-MJ6N6	29.8(1.17)	15.3(0.60)	14.0(0.55)	17.5(0.69)	4.8(0.19)	14.2(0.56)	26.2(1.03)
6	1/2	-L-MJ6N8	31.8(1.25)	15.3(0.60)	14.0(0.55)	20.6(0.81)	4.8(0.19)	19.1(0.75)	33.0(1.30)
8	1/8	-L-MJ8N2	28.8(1.13)	16.2(0.64)	16.0(0.63)	14.3(0.56)	4.8(0.19)	9.7(0.38)	19.8(0.78)
8	1/4	-L-MJ8N4	28.8(1.13)	16.2(0.64)	16.0(0.63)	14.3(0.56)	6.4(0.25)	14.2(0.56)	24.4(0.96)
8	3/8	-L-MJ8N6	30.6(1.20)	16.2(0.64)	16.0(0.63)	17.5(0.69)	6.4(0.25)	14.2(0.56)	26.2(1.03)
8	1/2	-L-MJ8N8	32.6(1.28)	16.2(0.64)	16.0(0.63)	20.6(0.81)	6.4(0.25)	19.1(0.75)	33.0(1.30)
10	1/8	-L-MJ10N2	31.5(1.24)	17.2(0.68)	19.0(0.75)	17.5(0.69)	4.8(0.19)	9.7(0.38)	21.6(0.85)
10	1/4	-L-MJ10N4	31.5(1.24)	17.2(0.68)	19.0(0.75)	17.5(0.69)	7.1(0.28)	14.2(0.56)	26.2(1.03)
10	3/8	-L-MJ10N6	31.5(1.24)	17.2(0.68)	19.0(0.75)	17.5(0.69)	7.9(0.31)	14.2(0.56)	26.2(1.03)
10	1/2	-L-MJ10N8	33.5(1.32)	17.2(0.68)	19.0(0.75)	20.6(0.81)	7.9(0.31)	19.1(0.75)	33.0(1.30)
12	1/8	-L-MJ12N2	36.0(1.42)	22.8(0.90)	22.0(0.87)	20.6(0.81)	4.8(0.19)	9.7(0.38)	23.6(0.93)
12	1/4	-L-MJ12N4	36.0(1.42)	22.8(0.90)	22.0(0.87)	20.6(0.81)	7.1(0.28)	14.2(0.56)	28.2(1.11)
12	3/8	-L-MJ12N6	36.0(1.42)	22.8(0.90)	22.0(0.87)	20.6(0.81)	9.5(0.37)	14.2(0.56)	28.2(1.11)
12	1/2	-L-MJ12N8	36.0(1.42)	22.8(0.90)	22.0(0.87)	20.6(0.81)	9.5(0.37)	19.1(0.75)	33.0(1.30)
12	3/4	-L-MJ12N12	39.8(1.57)	22.8(0.90)	22.0(0.87)	27.0(1.06)	9.5(0.37)	19.1(0.75)	36.8(1.45)
15	1/2	-L-MJ15N8	38.0(1.50)	24.4(0.96)	25.0(0.98)	23.8(0.94)	11.9(0.47)	19.1(0.75)	35.1(1.38)
16	1/4	-L-MJ16N4	38.0(1.50)	24.4(0.96)	25.0(0.98)	23.8(0.94)	7.1(0.28)	14.2(0.56)	30.2(1.19)
16	3/8	-L-MJ16N6	38.0(1.50)	24.4(0.96)	25.0(0.98)	23.8(0.94)	9.5(0.37)	14.2(0.56)	30.2(1.19)
16	1/2	-L-MJ16N8	38.0(1.50)	24.4(0.96)	25.0(0.98)	23.8(0.94)	11.9(0.47)	19.1(0.75)	35.1(1.38)
16	3/4	-L-MJ16N12	39.8(1.57)	24.4(0.96)	25.0(0.98)	27.0(1.06)	12.7(0.50)	19.1(0.75)	36.8(1.45)
18	1/2	-L-MJ18N8	39.8(1.57)	24.4(0.96)	30.0(1.18)	27.0(1.06)	11.9(0.47)	19.1(0.75)	36.8(1.45)
18	3/4	-L-MJ18N12	39.8(1.57)	24.4(0.96)	30.0(1.18)	27.0(1.06)	15.1(0.59)	19.1(0.75)	36.8(1.45)
20	1/2	-L-MJ20N8	44.6(1.76)	26.0(1.02)	32.0(1.26)	34.9(1.37)	11.9(0.47)	19.1(0.75)	41.7(1.64)
20	3/4	-L-MJ20N12	44.6(1.76)	26.0(1.02)	32.0(1.26)	34.9(1.37)	15.9(0.63)	19.1(0.75)	41.7(1.64)
22	3/4	-L-MJ22N12	44.6(1.76)	26.0(1.02)	32.0(1.26)	34.9(1.37)	15.9(0.63)	19.1(0.75)	41.7(1.64)
22	1	-L-MJ22N16	44.6(1.76)	26.0(1.02)	32.0(1.26)	34.9(1.37)	18.3(0.72)	23.9(0.94)	46.5(1.83)
25	3/4	-L-MJ25N12	49.1(1.93)	31.3(1.23)	38.0(1.50)	34.9(1.37)	15.9(0.63)	19.1(0.75)	41.7(1.64)
25	1	-L-MJ25N16	49.1(1.93)	31.3(1.23)	38.0(1.50)	34.9(1.37)	21.8(0.86)	23.9(0.94)	46.5(1.83)
30	1 1/4	-L-MJ30N20	69.9(2.75)	39.6(1.56)	50.0(1.97)	42.9(1.69)	26.2(1.03)	23.9(0.94)	53.1(2.09)
32	1 1/4	-L-MJ32N20	72.3(2.85)	42.0(1.65)	50.0(1.97)	42.9(1.69)	27.8(1.09)	23.9(0.94)	53.1(2.09)
38	1 1/2	-L-MJ38N24	84.0(3.31)	49.4(1.94)	60.0(2.36)	50.8(2.00)	33.7(1.33)	26.2(1.03)	60.4(2.38)

▶ 卡套阳螺纹弯头

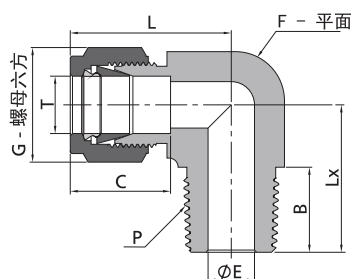

◆ 尺寸“E”为最小公称孔口,此孔口在管螺纹端、直螺纹端可能会更大。

公制 Tube 管			ISO 锥螺纹 (RT)						
T-Tube 管外径 (mm)	P-RT 尺寸	基本 订购号	尺寸, in. (mm)						
			L	C	G	F	E	B	Lx
3	1/8	-L-MJ3RT2	23.6(0.93)	12.9(0.51)	12.0(0.47)	11.1(0.44)	2.4(0.09)	9.7(0.38)	17.8(0.70)
3	1/4	-L-MJ3RT4	24.6(0.97)	12.9(0.51)	12.0(0.47)	12.7(0.50)	2.4(0.09)	14.2(0.56)	23.4(0.92)
4	1/8	-L-MJ4RT2	25.4(1.00)	13.7(0.54)	12.0(0.47)	12.7(0.50)	2.4(0.09)	9.7(0.38)	18.8(0.74)
4	1/4	-L-MJ4RT4	25.4(1.00)	13.7(0.54)	12.0(0.47)	12.7(0.50)	2.4(0.09)	14.2(0.56)	23.4(0.92)
6	1/8	-L-MJ6RT2	27.0(1.06)	15.3(0.60)	14.0(0.55)	12.7(0.50)	4.8(0.19)	9.7(0.38)	18.8(0.74)
6	1/4	-L-MJ6RT4	27.0(1.06)	15.3(0.60)	14.0(0.55)	12.7(0.50)	4.8(0.19)	14.2(0.56)	23.4(0.92)
6	3/8	-L-MJ6RT6	29.8(1.17)	15.3(0.60)	14.0(0.55)	17.5(0.69)	4.8(0.19)	14.2(0.56)	26.2(1.03)
6	1/2	-L-MJ6RT8	31.8(1.25)	15.3(0.60)	14.0(0.55)	20.6(0.81)	4.8(0.19)	19.1(0.75)	33.0(1.30)
8	1/8	-L-MJ8RT2	28.8(1.13)	16.2(0.64)	16.0(0.63)	14.3(0.56)	4.8(0.19)	9.7(0.38)	19.8(0.78)
8	1/4	-L-MJ8RT4	28.8(1.13)	16.2(0.64)	16.0(0.63)	14.3(0.56)	6.4(0.25)	14.2(0.56)	24.4(0.96)
8	3/8	-L-MJ8RT6	30.6(1.20)	16.2(0.64)	16.0(0.63)	17.5(0.69)	6.4(0.25)	14.2(0.56)	26.2(1.03)
8	1/2	-L-MJ8RT8	32.6(1.28)	16.2(0.64)	16.0(0.63)	20.6(0.81)	6.4(0.25)	19.1(0.75)	33.0(1.30)
10	1/8	-L-MJ10RT2	31.5(1.24)	17.2(0.68)	19.0(0.75)	17.5(0.69)	4.8(0.19)	9.7(0.38)	21.6(0.85)
10	1/4	-L-MJ10RT4	31.5(1.24)	17.2(0.68)	19.0(0.75)	17.5(0.69)	7.1(0.28)	14.2(0.56)	26.2(1.03)
10	3/8	-L-MJ10RT6	31.5(1.24)	17.2(0.68)	19.0(0.75)	17.5(0.69)	7.9(0.31)	14.2(0.56)	26.2(1.03)
10	1/2	-L-MJ10RT8	33.5(1.32)	17.2(0.68)	19.0(0.75)	20.6(0.81)	7.9(0.31)	19.1(0.75)	33.0(1.30)
12	1/8	-L-MJ12RT2	36.0(1.42)	22.8(0.90)	22.0(0.87)	20.6(0.81)	4.8(0.19)	9.7(0.38)	23.6(0.93)
12	1/4	-L-MJ12RT4	36.0(1.42)	22.8(0.90)	22.0(0.87)	20.6(0.81)	7.1(0.28)	14.2(0.56)	28.2(1.11)
12	3/8	-L-MJ12RT6	36.0(1.42)	22.8(0.90)	22.0(0.87)	20.6(0.81)	9.5(0.37)	14.2(0.56)	28.2(1.11)
12	1/2	-L-MJ12RT8	36.0(1.42)	22.8(0.90)	22.0(0.87)	20.6(0.81)	0.5(0.02)	19.1(0.75)	33.0(1.30)
12	3/4	-L-MJ12RT12	39.8(1.57)	22.8(0.90)	22.0(0.87)	27.0(1.06)	9.5(0.37)	19.1(0.75)	36.8(1.45)
14	1/2	-L-MJ14RT8	38.1(1.50)	24.4(0.96)	25.0(0.98)	23.8(0.94)	11.1(0.44)	19.1(0.75)	35.1(1.38)
15	1/2	-L-MJ15RT8	38.1(1.50)	24.4(0.96)	25.0(0.98)	23.8(0.94)	11.9(0.47)	19.1(0.75)	35.1(1.38)
16	1/4	-L-MJ16RT4	38.0(1.50)	24.4(0.96)	25.0(0.98)	23.8(0.94)	7.1(0.28)	14.2(0.56)	30.2(1.19)
16	3/8	-L-MJ16RT6	38.0(1.50)	24.4(0.96)	25.0(0.98)	23.8(0.94)	9.5(0.37)	14.2(0.56)	30.2(1.19)
16	1/2	-L-MJ16RT8	38.0(1.50)	24.4(0.96)	25.0(0.98)	23.8(0.94)	11.9(0.47)	19.1(0.75)	35.1(1.38)
16	3/4	-L-MJ16RT12	39.8(1.57)	24.4(0.96)	25.0(0.98)	27.0(1.06)	12.7(0.50)	19.1(0.75)	36.8(1.45)
18	1/2	-L-MJ18RT8	39.8(1.57)	24.4(0.96)	30.0(1.18)	27.0(1.06)	11.9(0.47)	19.1(0.75)	36.8(1.45)
18	3/4	-L-MJ18RT12	39.8(1.57)	24.4(0.96)	30.0(1.18)	27.0(1.06)	15.1(0.59)	19.1(0.75)	36.8(1.45)
20	1/2	-L-MJ20RT8	44.6(1.76)	26.0(0.90)	32.0(1.26)	34.9(1.37)	11.9(0.47)	19.1(0.75)	41.7(1.64)
20	3/4	-L-MJ20RT12	44.6(1.76)	26.0(0.90)	32.0(1.26)	34.9(1.37)	15.9(0.63)	19.1(0.75)	41.7(1.64)
22	3/4	-L-MJ22RT12	44.6(1.76)	26.0(0.90)	32.0(1.26)	34.9(1.37)	15.9(0.63)	19.1(0.75)	41.7(1.64)
22	1	-L-MJ22RT16	44.6(1.76)	26.0(0.90)	32.0(1.26)	34.9(1.37)	18.3(0.72)	23.9(0.94)	46.5(1.83)
25	3/4	-L-MJ25RT12	49.1(1.93)	31.3(0.90)	38.0(1.50)	34.9(1.37)	15.9(0.63)	19.1(0.75)	41.7(1.64)
25	1	-L-MJ25RT16	49.1(1.93)	31.3(0.90)	38.0(1.50)	34.9(1.37)	21.8(0.86)	23.9(0.94)	46.5(1.83)
28	1	-L-MJ28RT16	64.0(2.52)	36.6(0.90)	46.0(1.81)	42.9(1.69)	21.8(0.86)	23.9(0.94)	53.1(2.09)

► 45° 卡套阳螺纹弯头

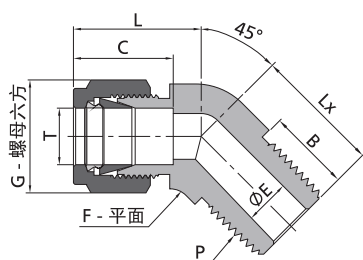

- ◆ 尺寸“E”为最小公称孔口,此孔口在管螺纹端、直螺纹端可能会更大。

英制 Tube管			NPT 螺纹						
T-Tube 管外径 (in.)	P-NPT 尺寸	基本 订购号	尺寸, in. (mm)						
			L	C	G	F	E	B	Lx
1/16	1/16	-R-FJ1N1	0.82(20.8)	0.34(8.6)	0.31(7.9)	0.44(11.1)	0.05(1.3)	0.38(9.7)	0.66(16.8)
1/8	1/8	-R-FJ2N2	0.82(20.8)	0.50(12.7)	0.44(11.1)	0.44(11.1)	0.09(2.3)	0.38(9.7)	0.66(16.8)
3/16	1/8	-R-FJ3N2	0.85(21.6)	0.54(13.7)	0.50(12.7)	0.44(11.1)	0.12(3.0)	0.38(9.7)	0.58(14.7)
1/4	1/8	-R-FJ4N2	0.97(24.6)	0.60(15.2)	0.56(14.3)	0.50(12.7)	0.19(4.8)	0.38(9.7)	0.65(16.5)
1/4	1/4	-R-FJ4N4	0.97(24.6)	0.60(15.2)	0.56(14.3)	0.50(12.7)	0.19(4.8)	0.56(14.2)	0.83(21.1)
5/16	1/8	-R-FJ5N2	0.94(24.0)	0.64(16.3)	0.63(15.9)	0.56(14.3)	0.19(4.8)	0.38(9.7)	0.66(16.8)
3/8	1/8	-R-FJ6N2	1.10(27.9)	0.66(16.8)	0.69(17.5)	0.63(15.9)	0.19(4.8)	0.38(9.7)	0.72(18.3)
3/8	1/4	-R-FJ6N4	1.10(27.9)	0.66(16.8)	0.69(17.5)	0.63(15.9)	0.28(7.1)	0.56(14.2)	0.90(22.9)
3/8	3/8	-R-FJ6N6	1.15(29.2)	0.66(16.8)	0.69(17.5)	0.81(20.6)	0.28(7.1)	0.56(14.2)	0.95(24.1)
1/2	3/8	-R-FJ8N6	1.26(32.0)	0.90(22.9)	0.87(22.2)	0.81(20.6)	0.38(9.7)	0.56(14.2)	0.95(24.1)
5/8	1/2	-R-FJ10N8	1.20(30.4)	0.96(24.4)	1.00(25.4)	0.94(23.8)	0.47(11.9)	0.75(19.1)	1.17(29.7)
3/4	3/4	-R-FJ12N12	1.34(34.0)	0.96(24.4)	1.13(28.6)	1.06(27.0)	0.62(15.7)	0.75(19.1)	1.22(31.0)
7/8	3/4	-R-FJ14N12	1.59(40.4)	1.02(25.9)	1.25(31.8)	1.25(31.8)	0.62(15.7)	0.75(19.1)	1.27(32.3)
1	1	-R-FJ16N16	1.59(40.4)	1.23(31.2)	1.50(38.1)	1.37(34.9)	0.88(22.4)	0.94(23.9)	1.49(37.8)

公制 Tube管			NPT 螺纹						
T-Tube 管外径 (mm)	P-NPT 尺寸	基本 订购号	尺寸, in. (mm)						
			L	C	G	F	E	B	Lx
6	1/8	-R-MJ6N2	23.4(0.92)	15.3(0.60)	14.0(0.55)	12.7(0.50)	4.8(0.19)	9.7(0.38)	16.8(0.66)
6	1/4	-R-MJ6N4	23.4(0.92)	15.3(0.60)	14.0(0.55)	12.7(0.50)	4.8(0.19)	14.2(0.56)	21.8(0.86)
8	1/8	-R-MJ8N2	24.3(0.96)	16.2(0.64)	16.0(0.63)	15.9(0.63)	4.8(0.19)	9.7(0.38)	16.8(0.66)
10	1/4	-R-MJ10N4	26.6(1.05)	17.2(0.68)	19.0(0.75)	17.5(0.69)	7.9(0.31)	14.2(0.56)	24.1(0.95)
12	3/8	-R-MJ12N6	29.1(1.15)	22.8(0.90)	22.0(0.87)	20.6(0.81)	9.5(0.37)	14.2(0.56)	24.1(0.95)
12	1/2	-R-MJ12N8	30.7(1.21)	22.8(0.90)	22.0(0.87)	20.6(0.81)	9.5(0.37)	19.1(0.75)	29.7(1.17)
16	1/2	-R-MJ16N8	30.4(1.20)	24.4(0.96)	25.0(0.98)	23.8(0.94)	11.9(0.47)	19.1(0.75)	29.7(1.17)

▶ 卡套阳螺纹位置可调弯头

SAE/MS 直螺纹

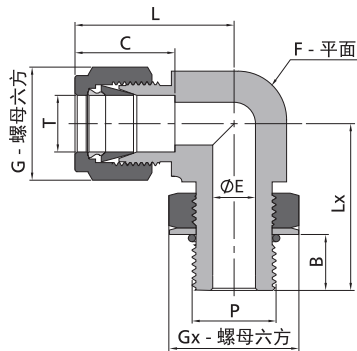

- ◆ 尺寸"E"为最小公称孔口,此孔口在管螺纹端、直螺纹端可能会更大。
- ◆ 转接至 SAE J1926-1、ISO 11926-1 和 MS 16142 直螺纹凸台。

英制 Tube 管				SAE/MS 直螺纹							
T-Tube 管外径 (in.)	P-SAE 名义 尺寸	P-SAE/MS 螺纹规格	基本 订购号	尺寸, in. (mm)							
				L	B	C	G	E	F	Lx	Gx
1/4	4	7/16-20	-L-FJ4SOT7	1.12(28.4)	0.39(9.9)	0.60(15.2)	0.56(14.3)	0.19(4.8)	0.50(12.7)	1.06(27.0)	0.56(14.3)
1/4	6	9/16-18	-L-FJ4SOT9	1.20(30.5)	0.44(11.2)	0.60(15.2)	0.56(14.3)	0.19(4.8)	0.63(15.9)	1.27(32.3)	0.69(17.5)
5/16	5	1/2-20	-L-FJ5SOT8	1.19(30.2)	0.39(9.9)	0.64(16.3)	0.63(15.9)	0.23(5.8)	0.56(14.3)	1.16(29.5)	0.63(15.9)
3/8	4	7/16-20	-L-FJ6SOT7	1.31(33.3)	0.39(9.9)	0.66(16.8)	0.69(17.5)	0.20(5.1)	0.63(15.9)	1.24(31.5)	0.56(14.3)
3/8	6	9/16-18	-L-FJ6SOT9	1.26(32.0)	0.44(11.2)	0.66(16.8)	0.69(17.5)	0.28(7.1)	0.63(15.9)	1.27(32.3)	0.69(17.5)
3/8	8	3/4-16	-L-FJ6SOT12	1.37(34.8)	0.50(12.7)	0.66(16.8)	0.69(17.5)	0.28(7.1)	0.81(20.6)	1.49(37.8)	0.87(22.2)
1/2	6	9/16-18	-L-FJ8SOT9	1.48(37.6)	0.44(11.2)	0.90(22.9)	0.87(22.2)	0.28(7.1)	0.81(20.6)	1.48(37.5)	0.69(17.5)
1/2	8	3/4-16	-L-FJ8SOT12	1.48(37.6)	0.50(12.7)	0.90(22.9)	0.87(22.2)	0.41(10.4)	0.81(20.6)	1.49(37.8)	0.87(22.2)
5/8	10	7/8-14	-L-FJ10SOT14	1.56(39.6)	0.56(14.2)	0.96(24.4)	1.00(25.4)	0.50(12.7)	0.94(23.8)	1.71(43.4)	1.00(25.4)
3/4	12	1 1/16-12	-L-FJ12SOT17	1.63(41.4)	0.66(16.8)	0.96(24.4)	1.13(28.6)	0.62(15.7)	1.06(27.0)	1.92(48.8)	1.25(31.8)
7/8	14	1 3/16-12	-L-FJ14SOT19	1.70(43.2)	0.66(16.8)	1.02(25.9)	1.25(31.8)	0.72(18.3)	1.25(31.8)	1.99(50.5)	1.37(34.9)
1	16	1 5/16-12	-L-FJ16SOT21	1.99(50.5)	0.66(16.8)	1.23(31.2)	1.50(38.1)	0.88(22.4)	1.37(34.9)	2.11(53.6)	1.50(38.1)
1 1/4	20	1 5/8-12	-L-FJ20SOT26	2.67(67.8)	0.66(16.8)	1.62(41.1)	1.87(47.6)	1.09(27.7)	1.69(42.9)	2.29(58.2)	1.87(47.6)
1 1/2	24	1 7/8-12	-L-FJ24SOT30	3.07(78.0)	0.66(16.8)	1.97(50.0)	2.25(57.2)	1.34(34.0)	2.00(50.8)	2.38(60.5)	2.13(54.0)

► 卡套阳螺纹位置可调弯头

ISO 平行螺纹

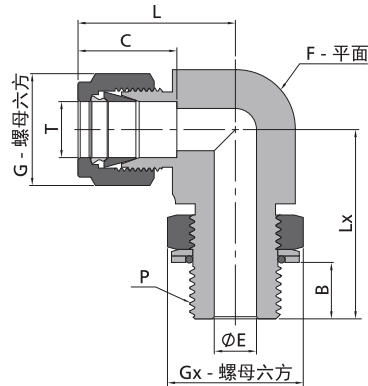

◆ 尺寸“E”为最小公称孔口,此孔口在管螺纹端、直螺纹端可能会更大。

英制 Tube 管			ISO 平行螺纹 (SBP)							
T-Tube 管外径 (in.)	P-ISO平行 螺纹尺寸	基本订购号	尺寸, in. (mm)							
			L	B	C	G	E	F	Lx	Gx
1/4	1/8	-L-FJ4SBP2	1.06(26.9)	0.26(6.6)	0.60(15.2)	0.56(14.3)	0.16(4.1)	0.50(12.7)	1.04(26.4)	0.56(14.3)
1/4	1/4	-L-FJ4SBP4	1.14(29.0)	0.35(9.0)	0.60(15.2)	0.56(14.3)	0.19(4.8)	0.63(15.9)	1.27(32.3)	0.75(19.1)
3/8	1/4	-L-FJ6SBP4	1.20(30.5)	0.35(9.0)	0.66(16.8)	0.69(17.5)	0.23(5.8)	0.63(15.9)	1.27(32.3)	0.75(19.1)
3/8	3/8	-L-FJ6SBP6	1.31(33.3)	0.37(9.4)	0.66(16.8)	0.69(17.5)	0.28(7.1)	0.81(20.6)	1.46(37.1)	0.87(22.2)
1/2	1/4	-L-FJ8SBP4	1.42(36.1)	0.35(9.0)	0.90(22.9)	0.87(22.2)	0.23(5.8)	0.81(20.6)	1.38(35.1)	0.75(19.1)
1/2	3/8	-L-FJ8SBP6	1.42(36.1)	0.37(9.4)	0.90(22.9)	0.87(22.2)	0.31(7.9)	0.81(20.6)	1.46(37.1)	0.87(22.2)
1/2	1/2	-L-FJ8SBP8	1.50(38.1)	0.51(13.0)	0.90(22.9)	0.87(22.2)	0.41(10.4)	0.94(23.8)	1.71(43.4)	1.06(27.0)
5/8	1/2	-L-FJ10SBP8	1.50(38.1)	0.51(13.0)	0.96(24.4)	1.00(25.4)	0.47(11.9)	0.94(23.8)	1.71(43.4)	1.06(27.0)
3/4	1/2	-L-FJ12SBP8	1.57(39.9)	0.51(13.0)	0.96(24.4)	1.13(28.6)	0.47(11.9)	1.06(27.0)	1.78(45.2)	1.06(27.0)
3/4	3/4	-L-FJ12SBP12	1.57(39.9)	0.51(13.0)	0.96(24.4)	1.13(28.6)	0.62(15.7)	1.06(27.0)	1.92(48.8)	1.37(34.9)
1	3/4	-L-FJ16SBP12	1.93(49.0)	0.51(13.0)	1.23(31.2)	1.50(38.1)	0.62(15.7)	1.37(34.9)	2.10(53.3)	1.37(34.9)
1	1	-L-FJ16SBP16	1.93(49.0)	0.52(13.2)	1.23(31.2)	1.50(38.1)	0.78(19.8)	1.37(34.9)	2.11(53.6)	1.63(41.3)

公制 Tube 管			ISO 平行螺纹 (SBP)							
T-Tube 管外径 (mm)	P-ISO平行 螺纹尺寸	基本订购号	尺寸, mm (in.)							
			L	B	C	G	E	F	Lx	Gx
6	1/8	-L-MJ6SBP2	27.0(1.06)	6.6(0.26)	15.3(0.60)	14.0(0.55)	4.0(0.16)	12.7(0.50)	26.4(1.04)	14.3(0.56)
6	1/4	-L-MJ6SBP4	29.0(1.14)	9.0(0.35)	15.3(0.60)	14.0(0.55)	4.8(0.19)	15.9(0.63)	32.3(1.27)	19.1(0.75)
8	1/8	-L-MJ8SBP2	28.8(1.13)	6.6(0.26)	16.2(0.64)	16.0(0.63)	4.0(0.16)	14.3(0.56)	27.4(1.08)	14.3(0.56)
8	1/4	-L-MJ8SBP4	29.9(1.18)	9.0(0.35)	16.2(0.64)	16.0(0.63)	5.9(0.23)	15.9(0.63)	32.2(1.27)	19.1(0.75)
10	1/4	-L-MJ10SBP4	33.5(1.32)	9.0(0.35)	17.2(0.68)	19.0(0.75)	5.9(0.23)	20.6(0.81)	35.0(1.38)	19.1(0.75)
10	3/8	-L-MJ10SBP6	33.5(1.32)	9.4(0.37)	17.2(0.68)	19.0(0.75)	7.9(0.31)	20.6(0.81)	37.1(1.46)	22.2(0.87)
12	1/4	-L-MJ12SBP4	36.0(1.42)	9.0(0.35)	22.8(0.90)	22.0(0.87)	5.9(0.23)	20.6(0.81)	35.0(1.38)	19.1(0.75)
12	3/8	-L-MJ12SBP6	36.0(1.42)	9.4(0.37)	22.8(0.90)	22.0(0.87)	7.9(0.31)	20.6(0.81)	37.1(1.46)	22.2(0.87)
12	1/2	-L-MJ12SBP8	38.0(1.50)	13.0(0.51)	22.8(0.90)	22.0(0.87)	9.5(0.37)	23.8(0.94)	43.4(1.71)	27.0(1.06)
12	3/4	-L-MJ12SBP12	39.8(1.57)	13.0(0.51)	22.8(0.90)	22.0(0.87)	9.5(0.37)	27.0(1.06)	48.8(1.92)	34.9(1.37)

► 45° 卡套阳螺纹位置可调弯头

SAE/MS 直螺纹

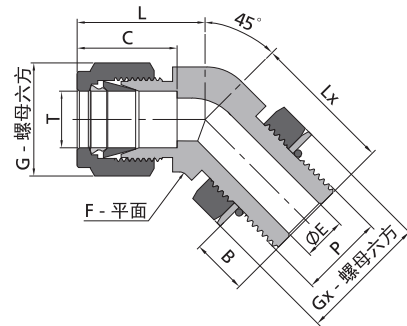

- ◆ 尺寸"E"为最小公称孔口,此孔口在管螺纹端、直螺纹端可能会更大。
- ◆ 转接至 SAE J1926-1、ISO 11926-1 和 MS 16142 直螺纹凸台。

英制 Tube 管				SAE/MS 直螺纹								
T-Tube 管外径 (in.)	P-SAE 名义 尺寸	P-SAE/MS 螺纹规格	基本订购号	尺寸, in. (mm)								
				L	B	C	G	E	F	Lx	Gx	
1/4	4	7/16-20	-R-FJ4SOT7	1.01(25.7)	0.39(9.9)	0.60(15.2)	0.56(14.3)	0.19(4.8)	0.50(12.7)	1.01(25.7)	0.56(14.3)	
3/8	6	9/16-18	-R-FJ6SOT9	1.10(27.9)	0.44(11.2)	0.66(16.8)	0.69(17.5)	0.28(7.1)	0.63(15.9)	1.11(28.2)	0.69(17.5)	
1/2	8	3/4-16	-R-FJ8SOT12	1.26(32.0)	0.50(12.7)	0.90(22.9)	0.87(22.2)	0.41(10.4)	0.81(20.6)	1.27(32.3)	0.87(22.2)	
3/4	12	1 1/16-12	-R-FJ12SOT17	1.57(39.9)	0.66(16.8)	0.96(24.4)	1.13(28.6)	0.62(15.7)	1.06(27.0)	1.86(47.2)	1.25(31.8)	
1	16	1 5/16-12	-R-FJ16SOT21	1.87(47.5)	0.66(16.8)	1.23(31.2)	1.50(38.1)	0.88(22.4)	1.37(34.9)	1.99(50.5)	1.50(38.1)	

▶ 卡套阴螺纹弯头

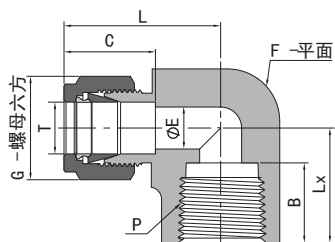

英制 Tube 管			NPT 螺纹						
T-Tube 管外径 (in.)	P-NPT 尺寸	基本 订购号	尺寸, in. (mm)						
			L	B	C	G	E	F	Lx
1/16	1/16	-L-FJ1FN1	0.71(18.0)	0.39(9.9)	0.34(8.6)	0.31(7.9)	0.05(1.3)	0.44(11.1)	0.56(14.2)
1/16	1/8	-L-FJ1FN2	0.81(20.6)	0.41(10.4)	0.34(8.6)	0.31(7.9)	0.05(1.3)	0.56(14.3)	0.75(19.1)
1/8	1/8	-L-FJ2FN2	0.97(24.6)	0.41(10.4)	0.50(12.7)	0.44(11.1)	0.09(2.3)	0.50(12.7)	0.75(19.1)
1/8	1/4	-L-FJ2FN4	1.08(27.4)	0.59(15.0)	0.50(12.7)	0.44(11.1)	0.09(2.3)	0.69(17.5)	0.88(22.4)
3/16	1/8	-L-FJ3FN2	1.00(25.4)	0.41(10.4)	0.54(13.7)	0.50(12.7)	0.12(3.0)	0.50(12.7)	0.75(19.1)
1/4	1/8	-L-FJ4FN2	1.06(26.9)	0.41(10.4)	0.60(15.2)	0.56(14.3)	0.19(4.8)	0.50(12.7)	0.75(19.1)
1/4	1/4	-L-FJ4FN4	1.17(29.7)	0.59(15.0)	0.60(15.2)	0.56(14.3)	0.19(4.8)	0.69(17.5)	0.88(22.4)
1/4	3/8	-L-FJ4FN6	1.25(31.8)	0.59(15.0)	0.60(15.2)	0.56(14.3)	0.19(4.8)	0.81(20.6)	0.88(22.4)
1/4	1/2	-L-FJ4FN8	1.36(34.5)	0.78(19.8)	0.60(15.2)	0.56(14.3)	0.19(4.8)	1.00(25.4)	1.12(28.4)
5/16	1/8	-L-FJ5FN2	1.13(28.7)	0.41(10.4)	0.64(16.3)	0.63(15.9)	0.25(6.4)	0.56(14.3)	0.75(19.1)
5/16	1/4	-L-FJ5FN4	1.20(30.5)	0.59(15.0)	0.64(16.3)	0.63(15.9)	0.25(6.4)	0.69(17.5)	0.88(22.4)
3/8	1/8	-L-FJ6FN2	1.20(30.5)	0.41(10.4)	0.66(16.8)	0.69(17.5)	0.28(7.1)	0.63(15.9)	0.75(19.1)
3/8	1/4	-L-FJ6FN4	1.23(31.2)	0.59(15.0)	0.66(16.8)	0.69(17.5)	0.28(7.1)	0.69(17.5)	0.88(22.4)
3/8	3/8	-L-FJ6FN6	1.31(33.3)	0.59(15.0)	0.66(16.8)	0.69(17.5)	0.28(7.1)	0.81(20.6)	0.88(22.4)
3/8	1/2	-L-FJ6FN8	1.42(36.1)	0.78(19.8)	0.66(16.8)	0.69(17.5)	0.28(7.1)	1.00(25.4)	1.12(28.4)
1/2	1/4	-L-FJ8FN4	1.42(36.1)	0.59(15.0)	0.90(22.9)	0.87(22.2)	0.41(10.4)	0.81(20.6)	0.88(22.4)
1/2	3/8	-L-FJ8FN6	1.42(36.1)	0.59(15.0)	0.90(22.9)	0.87(22.2)	0.41(10.4)	0.81(20.6)	0.88(22.4)
1/2	1/2	-L-FJ8FN8	1.53(38.9)	0.78(19.8)	0.90(22.9)	0.87(22.2)	0.41(10.4)	1.00(25.4)	1.12(28.4)
5/8	3/8	-L-FJ10FN6	1.50(38.1)	0.59(15.0)	0.96(24.4)	1.00(25.4)	0.50(12.7)	0.94(23.8)	0.88(22.4)
5/8	1/2	-L-FJ10FN8	1.57(39.9)	0.78(19.8)	0.96(24.4)	1.00(25.4)	0.50(12.7)	1.06(27.0)	1.12(28.4)
3/4	1/2	-L-FJ12FN8	1.57(39.9)	0.78(19.8)	0.96(24.4)	1.13(28.6)	0.62(15.7)	1.06(27.0)	1.12(28.4)
3/4	3/4	-L-FJ12FN12	1.76(44.7)	0.81(20.6)	0.96(24.4)	1.13(28.6)	0.62(15.7)	1.37(34.9)	1.25(31.8)
7/8	3/4	-L-FJ14FN12	1.76(44.7)	0.81(20.6)	1.02(25.9)	1.25(31.8)	0.72(18.3)	1.37(34.9)	1.25(31.8)
1	3/4	-L-FJ16FN12	1.93(49.0)	0.81(20.6)	1.23(31.2)	1.50(38.1)	0.88(22.4)	1.37(34.9)	1.25(31.8)
1	1	-L-FJ16FN16	2.11(53.6)	1.00(25.4)	1.23(31.2)	1.50(38.1)	0.88(22.4)	1.69(42.9)	1.50(38.1)

公制 Tube 管			NPT 螺纹						
T-Tube 管外径 (mm)	P-NPT 尺寸	基本 订购号	尺寸, mm (in.)						
			L	B	C	G	E	F	Lx
6	1/8	-L-MJ6FN2	27.0(1.06)	10.4(0.41)	15.3(0.60)	14.0(0.55)	4.8(0.19)	12.7(0.50)	19.0(0.75)
6	1/4	-L-MJ6FN4	29.8(1.17)	15.0(0.59)	15.3(0.60)	14.0(0.55)	4.8(0.19)	17.5(0.69)	22.4(0.88)
8	1/8	-L-MJ8FN2	28.8(1.13)	10.4(0.41)	16.2(0.64)	16.0(0.63)	6.4(0.25)	14.3(0.56)	19.1(0.75)
8	1/4	-L-MJ8FN4	30.6(1.20)	15.0(0.59)	16.2(0.64)	16.0(0.63)	6.4(0.25)	17.5(0.69)	22.4(0.88)
10	1/4	-L-MJ10FN4	33.5(1.32)	15.0(0.59)	17.2(0.68)	19.0(0.75)	7.9(0.31)	20.6(0.81)	22.4(0.88)
10	3/8	-L-MJ10FN6	33.5(1.32)	15.0(0.59)	17.2(0.68)	19.0(0.75)	7.9(0.31)	20.6(0.81)	22.4(0.88)
10	1/2	-L-MJ10FN8	36.6(1.44)	19.8(0.78)	17.2(0.68)	19.0(0.75)	7.9(0.31)	25.4(1.00)	28.5(1.12)
12	1/4	-L-MJ12FN4	36.0(1.42)	15.0(0.59)	22.8(0.90)	22.0(0.87)	9.5(0.37)	20.6(0.81)	22.4(0.88)
12	3/8	-L-MJ12FN6	36.0(1.42)	15.0(0.59)	22.8(0.90)	22.0(0.87)	9.5(0.37)	20.6(0.81)	22.4(0.88)
12	1/2	-L-MJ12FN8	38.8(1.53)	19.8(0.78)	22.8(0.90)	22.0(0.87)	9.5(0.37)	25.4(1.00)	28.4(1.12)
16	3/8	-L-MJ16FN6	39.5(1.56)	15.0(0.59)	24.4(0.96)	25.0(0.98)	12.7(0.50)	27.0(1.06)	23.6(0.93)
16	1/2	-L-MJ16FN8	39.5(1.56)	19.8(0.78)	24.4(0.96)	25.0(0.98)	12.7(0.50)	27.0(1.06)	28.5(1.12)

▶ 卡套弯头

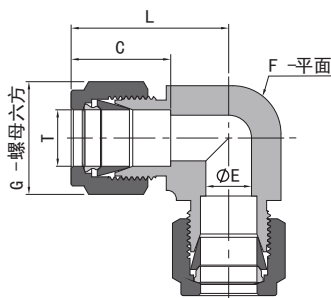

英制 Tube 管						
T-Tube 管外径 (in.)	基本 订购号	尺寸, in. (mm)				
		L	C	G	F	E
1/16	-L-FJ1	0.70(17.8)	0.34(8.6)	0.31(7.9)	0.37(9.5)	0.05(1.3)
1/8	-L-FJ2	0.88(22.4)	0.50(12.7)	0.44(11.1)	0.37(9.5)	0.09(2.3)
3/16	-L-FJ3	1.00(25.4)	0.54(13.7)	0.50(12.7)	0.50(12.7)	0.12(3.0)
1/4	-L-FJ4	1.06(26.9)	0.60(15.2)	0.56(14.3)	0.50(12.7)	0.19(4.8)
5/16	-L-FJ5	1.13(28.7)	0.64(16.3)	0.63(15.9)	0.56(14.3)	0.25(6.4)
3/8	-L-FJ6	1.20(30.5)	0.66(16.8)	0.69(17.5)	0.63(15.9)	0.28(7.1)
1/2	-L-FJ8	1.42(36.1)	0.90(22.9)	0.87(22.2)	0.81(20.6)	0.41(10.4)
5/8	-L-FJ10	1.50(38.1)	0.96(24.4)	1.00(25.4)	0.94(23.8)	0.5(12.7)
3/4	-L-FJ12	1.57(39.9)	0.96(24.4)	1.13(28.6)	1.06(27.0)	0.62(15.7)
7/8	-L-FJ14	1.76(44.7)	1.02(25.9)	1.25(31.8)	1.37(34.9)	0.72(18.3)
1	-L-FJ16	1.93(49.0)	1.23(31.2)	1.50(38.1)	1.37(34.9)	0.88(22.4)
1 1/8	-L-FJ18	2.63(66.9)	1.44(36.7)	1.75(44.5)	1.69(42.9)	0.97(24.6)
1 1/4	-L-FJ20	2.62(66.5)	1.62(41.1)	1.87(47.6)	1.69(42.9)	1.09(27.7)
1 1/2	-L-FJ24	3.07(78.0)	1.97(50.0)	2.25(57.2)	2.00(50.8)	1.34(34.0)

公制 Tube 管						
T-Tube 管外径 (mm)	基本 订购号	尺寸, mm (in.)				
		L	C	G	F	E
3	-L-MJ3	22.3(0.88)	12.9(0.51)	12.0(0.47)	9.5(0.37)	2.4(0.09)
4	-L-MJ4	25.4(1.00)	13.7(0.54)	12.0(0.47)	12.7(0.50)	2.4(0.09)
6	-L-MJ6	27.0(1.06)	15.3(0.60)	14.0(0.55)	12.7(0.50)	4.8(0.19)
8	-L-MJ8	28.8(1.13)	16.2(0.64)	16.0(0.63)	14.3(0.56)	6.4(0.25)
10	-L-MJ10	31.5(1.24)	17.2(0.68)	19.0(0.75)	17.5(0.69)	7.9(0.31)
12	-L-MJ12	36.0(1.42)	22.8(0.90)	22.0(0.87)	20.6(0.81)	9.5(0.37)
14	-L-MJ14	38.0(1.50)	24.4(0.96)	25.0(0.98)	23.8(0.94)	11.0(0.43)
15	-L-MJ15	38.0(1.50)	24.4(0.96)	25.0(0.98)	23.8(0.94)	11.9(0.47)
16	-L-MJ16	38.0(1.50)	24.4(0.96)	25.0(0.98)	23.8(0.94)	12.7(0.50)
18	-L-MJ18	39.8(1.57)	24.4(0.96)	30.0(1.18)	27.0(1.06)	15.1(0.59)
20	-L-MJ20	44.6(1.76)	26.0(1.02)	32.0(1.26)	34.9(1.37)	15.9(0.63)
22	-L-MJ22	44.6(1.76)	26.0(1.02)	32.0(1.26)	34.9(1.37)	18.3(0.72)
25	-L-MJ25	49.1(1.93)	31.3(1.23)	38.0(1.5)	34.9(1.37)	21.8(0.86)
28	-L-MJ28	64.0(2.52)	36.6(1.44)	46.0(1.81)	42.9(1.69)	21.8(0.86)
30	-L-MJ30	69.9(2.75)	39.6(1.56)	50.0(1.97)	42.9(1.69)	26.2(1.03)
32	-L-MJ32	72.3(2.85)	42.0(1.65)	50.0(1.97)	42.9(1.69)	28.6(1.13)
38	-L-MJ38	84.0(3.31)	49.4(1.94)	60.0(2.36)	50.8(2.00)	33.7(1.33)

▶ 卡套变径弯头

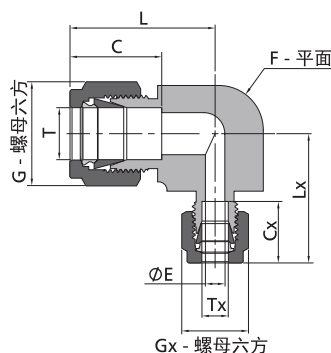

英制 Tube管										
T-Tube 管外径 (in.)	T-Tube 管外径 (in.)	基本 订购号	尺寸, in. (mm)							
			L	C	G	F	E	Cx	Gx	Lx
3/16	1/8	-L-FJ3FJ2	1.00(25.4)	0.54(13.7)	0.50(12.7)	0.50(12.7)	0.09(2.3)	0.50(12.7)	0.44(11.1)	0.97(24.7)
1/4	1/8	-L-FJ4FJ2	1.06(26.9)	0.60(15.2)	0.56(14.3)	0.50(12.7)	0.09(2.3)	0.50(12.7)	0.44(11.1)	1.00(25.4)
5/16	1/8	-L-FJ5FJ2	1.17(29.7)	0.64(16.3)	0.63(15.9)	0.56(14.3)	0.09(2.3)	0.50(12.7)	0.44(11.1)	1.04(26.4)
5/16	1/4	-L-FJ5FJ4	1.17(29.7)	0.64(16.3)	0.63(15.9)	0.56(14.3)	0.19(4.8)	0.60(15.2)	0.56(14.3)	1.14(29.0)
3/8	1/8	-L-FJ6FJ2	1.20(30.5)	0.66(16.8)	0.69(17.5)	0.63(15.9)	0.09(2.3)	0.50(12.7)	0.44(11.1)	1.04(26.4)
3/8	1/4	-L-FJ6FJ4	1.20(30.5)	0.66(16.8)	0.69(17.5)	0.63(15.9)	0.19(4.8)	0.60(15.2)	0.56(14.3)	1.14(29.0)
3/8	5/16	-L-FJ6FJ5	1.20(30.5)	0.66(16.8)	0.69(17.5)	0.63(15.9)	0.25(6.4)	0.64(16.3)	0.63(15.9)	1.17(29.7)
1/2	1/4	-L-FJ8FJ4	1.42(36.1)	0.90(22.9)	0.87(22.2)	0.81(20.6)	0.19(4.8)	0.60(15.2)	0.56(14.3)	1.27(32.2)
1/2	5/16	-L-FJ8FJ5	1.42(36.1)	0.90(22.9)	0.87(22.2)	0.81(20.6)	0.25(6.4)	0.64(16.3)	0.63(15.9)	1.28(32.5)
1/2	3/8	-L-FJ8FJ6	1.42(36.1)	0.90(22.9)	0.87(22.2)	0.81(20.6)	0.28(7.1)	0.66(16.8)	0.69(17.5)	1.32(33.6)
5/8	3/8	-L-FJ10FJ6	1.50(38.1)	0.96(24.4)	1.00(25.4)	0.94(23.8)	0.28(7.1)	0.66(16.8)	0.69(17.5)	1.40(35.6)
5/8	1/2	-L-FJ10FJ8	1.50(38.1)	0.96(24.4)	1.00(25.4)	0.94(23.8)	0.41(10.4)	0.90(22.9)	0.87(22.2)	1.50(38.1)
3/4	1/4	-L-FJ12FJ4	1.57(39.9)	0.96(24.4)	1.13(28.6)	1.06(27.0)	0.19(4.8)	0.60(15.2)	0.56(14.3)	1.41(35.9)
3/4	3/8	-L-FJ12FJ6	1.57(39.9)	0.96(24.4)	1.13(28.6)	1.06(27.0)	0.28(7.1)	0.66(16.8)	0.69(17.5)	1.47(37.4)
3/4	1/2	-L-FJ12FJ8	1.57(39.9)	0.96(24.4)	1.13(28.6)	1.06(27.0)	0.41(10.4)	0.90(22.9)	0.87(22.2)	1.57(39.9)
7/8	1/4	-L-FJ14FJ4	1.76(44.7)	1.02(25.9)	1.25(31.8)	1.37(34.9)	0.19(4.8)	0.60(15.2)	0.56(14.3)	1.60(40.7)
1	1/2	-L-FJ16FJ8	1.93(49.0)	1.23(31.2)	1.50(38.1)	1.37(34.9)	0.41(10.4)	0.90(22.9)	0.87(22.2)	1.75(44.4)
1	3/4	-L-FJ16FJ12	1.93(49.0)	1.23(31.2)	1.50(38.1)	1.37(34.9)	0.62(15.7)	0.96(24.4)	1.13(28.6)	1.85(47.1)

公制 Tube管										
T-Tube 管外径 (mm)	T-Tube 管外径 (mm)	基本 订购号	尺寸, in. (mm)							
			L	C	G	F	E	Cx	Gx	Lx
8	6	-L-MJ8MJ6	28.8(1.13)	16.2(0.64)	16.0(0.63)	14.3(0.56)	4.8(0.19)	15.3(0.60)	14.0(0.55)	27.9(1.10)
10	8	-L-MJ10MJ8	31.5(1.24)	17.2(0.68)	19.0(0.75)	17.5(0.69)	6.4(0.25)	16.2(0.64)	16.0(0.63)	30.5(1.20)
12	8	-L-MJ12MJ8	36.0(1.42)	22.8(0.90)	22.0(0.87)	20.6(0.81)	6.4(0.25)	16.2(0.64)	16.0(0.63)	32.6(1.28)
14	8	-L-MJ14MJ8	38.8(1.53)	24.4(0.96)	25.0(0.98)	23.8(0.94)	6.4(0.25)	16.2(0.64)	16.0(0.63)	34.7(1.37)
14	10	-L-MJ14MJ10	38.8(1.53)	24.4(0.96)	25.0(0.98)	23.8(0.94)	7.9(0.31)	17.2(0.68)	19.0(0.75)	35.5(1.4)

▶▶ 卡套双穿板弯头

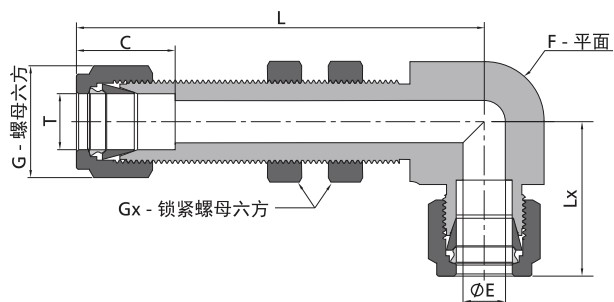

英制 Tube管										
T-Tube 管外径 (in.)	基本 订购号	尺寸, in. (mm)							面板孔尺寸 in. (mm)	最大面板厚 度in. (mm)
		L	C	E	G	F	Lx	Gx		
1/8	-L-BFJ2	1.93(49.0)	0.50(12.7)	0.09(2.3)	0.44(11.1)	0.37(9.5)	0.88(22.4)	0.50(12.7)	0.33(8.3)	0.60(15.2)
3/16	-L-BFJ3	2.03(51.6)	0.54(13.7)	0.12(3.0)	0.50(12.7)	0.50(12.7)	1.00(25.4)	0.56(14.3)	0.39(9.9)	0.61(15.5)
1/4	-L-BFJ4	2.10(53.3)	0.60(15.2)	0.19(4.8)	0.56(14.3)	0.50(12.7)	1.06(26.9)	0.63(15.9)	0.45(11.5)	0.61(15.5)
5/16	-L-BFJ5	2.30(58.4)	0.64(16.3)	0.25(6.4)	0.63(15.9)	0.63(15.9)	1.13(28.7)	0.69(17.5)	0.52(13.1)	0.74(18.8)
3/8	-L-BFJ6	2.36(59.9)	0.66(16.8)	0.28(7.1)	0.69(15.7)	0.63(15.9)	1.20(30.5)	0.75(19.1)	0.58(14.7)	0.74(18.8)
1/2	-L-BFJ8	2.67(67.8)	0.90(22.9)	0.41(10.4)	0.87(22.2)	0.81(20.6)	1.42(36.1)	0.94(23.8)	0.76(19.4)	0.74(18.8)
5/8	-L-BFJ10	2.82(71.6)	0.96(24.4)	0.50(12.7)	1.00(25.4)	0.94(23.8)	1.50(38.1)	1.06(27.0)	0.89(22.6)	0.50(12.7)
3/4	-L-BFJ12	3.08(78.2)	0.96(24.4)	0.62(12.7)	1.13(28.6)	1.06(27.0)	1.57(39.9)	1.19(30.2)	1.02(25.8)	0.66(16.8)

▶ 支管阳螺纹卡套三通

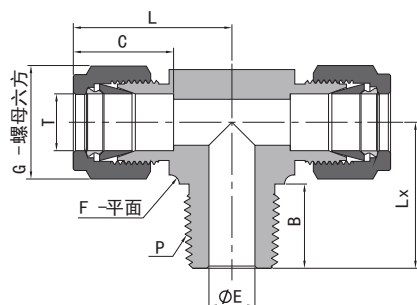

◆ 尺寸"E"为最小公称孔口,此孔口在管螺纹端、直螺纹端可能会更大。

英制 Tube 管			NPT 螺纹						
T-Tube 管外径 (in.)	P-NPT 尺寸	基本 订购号	尺寸, in. (mm)						
			L	C	G	F	E	B	Lx
1/8	1/8	-T-FJ2FJ2N2	0.93(23.6)	0.50(12.7)	0.44(11.1)	0.44(11.1)	0.09(2.3)	0.38(9.7)	0.70(17.8)
1/8	1/4	-T-FJ2FJ2N4	0.97(24.6)	0.50(12.7)	0.44(11.1)	0.50(12.7)	0.09(2.3)	0.56(14.2)	0.92(23.4)
3/16	1/8	-T-FJ3FJ3N2	0.96(24.4)	0.54(13.7)	0.50(12.7)	0.44(11.1)	0.12(3.0)	0.38(9.7)	0.70(17.8)
1/4	1/8	-T-FJ4FJ4N2	1.06(26.9)	0.60(15.2)	0.56(14.3)	0.50(12.7)	0.19(4.8)	0.38(9.7)	0.74(18.8)
1/4	1/4	-T-FJ4FJ4N4	1.06(26.9)	0.60(15.2)	0.56(14.3)	0.50(12.7)	0.19(4.8)	0.56(14.2)	0.92(23.4)
5/16	1/8	-T-FJ5FJ5N2	1.17(29.7)	0.64(16.3)	0.63(15.9)	0.63(15.9)	0.19(4.8)	0.38(9.7)	0.82(20.8)
5/16	1/4	-T-FJ5FJ5N4	1.17(29.7)	0.64(16.3)	0.63(15.9)	0.63(15.9)	0.25(6.4)	0.56(14.2)	1.01(25.7)
3/8	1/4	-T-FJ6FJ6N4	1.20(30.5)	0.66(16.8)	0.69(17.5)	0.63(15.9)	0.28(7.1)	0.56(14.2)	1.00(25.4)
3/8	3/8	-T-FJ6FJ6N6	1.31(33.3)	0.66(16.8)	0.69(17.5)	0.81(20.6)	0.28(7.1)	0.56(14.2)	1.11(28.2)
1/2	3/8	-T-FJ8FJ8N6	1.42(36.1)	0.90(22.9)	0.87(22.2)	0.81(20.6)	0.38(9.7)	0.56(14.2)	1.11(28.2)
1/2	1/2	-T-FJ8FJ8N8	1.42(36.1)	0.90(22.9)	0.87(22.2)	0.81(20.6)	0.41(10.4)	0.75(19.1)	1.30(33.0)
5/8	1/2	-T-FJ10FJ10N8	1.53(38.9)	0.96(24.4)	1.00(25.4)	1.00(25.4)	0.47(11.9)	0.75(19.1)	1.41(35.8)
3/4	3/4	-T-FJ12FJ12N12	1.57(39.9)	0.96(24.4)	1.13(28.6)	1.06(27.0)	0.62(15.7)	0.75(19.1)	1.45(36.8)
7/8	3/4	-T-FJ14FJ14N12	1.88(47.8)	1.02(25.9)	1.25(31.8)	1.37(34.9)	0.62(15.7)	0.75(19.1)	1.87(47.5)
1	3/4	-T-FJ16FJ16N12	1.94(49.3)	1.23(31.2)	1.50(38.1)	1.37(34.9)	0.62(15.7)	0.75(19.1)	1.87(47.5)
1	1	-T-FJ16FJ16N16	1.94(49.3)	1.23(31.2)	1.50(38.1)	1.37(34.9)	0.88(22.4)	0.94(23.9)	1.84(46.7)

公制 Tube 管			NPT 螺纹						
T-Tube 管外径 (mm)	P-NPT 尺寸	基本 订购号	尺寸, mm (in.)						
			L	C	G	F	E	B	Lx
6	1/8	-T-MJ6MJ6N2	27.0(1.06)	15.3(0.60)	14.0(0.55)	12.7(0.50)	4.8(0.19)	9.7(0.38)	18.8(0.74)
6	1/4	-T-MJ6MJ6N4	27.0(1.06)	15.3(0.60)	14.0(0.55)	12.7(0.50)	4.8(0.19)	14.2(0.56)	23.4(0.92)
8	1/8	-T-MJ8MJ8N2	29.9(1.18)	16.2(0.64)	16.0(0.63)	15.9(0.63)	4.8(0.19)	9.7(0.38)	20.8(0.82)
8	1/4	-T-MJ8MJ8N4	29.9(1.18)	16.2(0.64)	16.0(0.63)	15.9(0.63)	6.4(0.25)	14.2(0.56)	25.4(1.00)
10	1/4	-T-MJ10MJ10N4	33.5(1.32)	17.2(0.68)	19.0(0.75)	20.6(0.81)	7.1(0.28)	14.2(0.56)	28.2(1.11)
10	3/8	-T-MJ10MJ10N6	33.5(1.32)	17.2(0.68)	19.0(0.75)	20.6(0.81)	7.9(0.31)	14.2(0.56)	28.2(1.11)
12	1/4	-T-MJ12MJ12N4	36.0(1.42)	22.8(0.90)	22.0(0.87)	20.6(0.81)	7.1(0.28)	14.2(0.56)	28.2(1.11)
12	3/8	-T-MJ12MJ12N6	36.0(1.42)	22.8(0.90)	22.0(0.87)	20.6(0.81)	9.5(0.37)	14.2(0.56)	28.2(1.11)
12	1/2	-T-MJ12MJ12N8	36.0(1.42)	22.8(0.90)	22.0(0.87)	20.6(0.81)	9.5(0.37)	19.1(0.75)	33.0(1.30)
16	1/2	-T-MJ16MJ16N8	38.8(1.53)	24.4(0.96)	25.0(0.98)	25.4(1.00)	11.9(0.47)	19.1(0.75)	35.8(1.41)

▶ 主管阳螺纹卡套三通

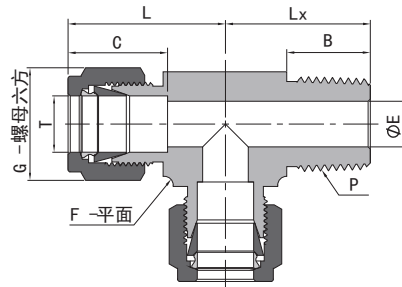

◆ 尺寸“E”为最小公称孔口,此孔口在管螺纹端、直螺纹端可能会更大。

英制 Tube 管			NPT 螺纹						
T-Tube 管外径 (in.)	P-NPT 尺寸	基本 订购号	尺寸, in. (mm)						
			L	C	G	F	E	B	Lx
1/8	1/8	-T-FJ2N2FJ2	0.93(23.6)	0.50(12.7)	0.44(11.1)	0.44(11.1)	0.09(2.3)	0.38(9.7)	0.70(17.8)
1/8	1/4	-T-FJ2N4FJ2	0.97(24.6)	0.50(12.7)	0.44(11.1)	0.50(12.7)	0.09(2.3)	0.56(14.2)	0.92(23.4)
3/16	1/8	-T-FJ3N2FJ3	0.96(24.4)	0.54(13.7)	0.50(12.7)	0.44(11.1)	0.12(3.0)	0.38(9.7)	0.70(17.8)
1/4	1/8	-T-FJ4N2FJ4	1.06(26.9)	0.60(15.2)	0.56(14.3)	0.50(12.7)	0.19(4.8)	0.38(9.7)	0.74(18.8)
1/4	1/4	-T-FJ4N4FJ4	1.06(26.9)	0.60(15.2)	0.56(14.3)	0.50(12.7)	0.19(4.8)	0.56(14.2)	0.92(23.4)
5/16	1/8	-T-FJ5N2FJ5	1.17(29.7)	0.64(16.3)	0.63(15.9)	0.63(15.9)	0.19(4.8)	0.38(9.7)	0.82(20.8)
5/16	1/4	-T-FJ5N4FJ5	1.17(29.7)	0.64(16.3)	0.63(15.9)	0.63(15.9)	0.25(6.4)	0.56(14.2)	1.01(25.7)
3/8	1/4	-T-FJ6N4FJ6	1.20(30.5)	0.66(16.8)	0.69(17.5)	0.63(15.9)	0.28(7.1)	0.56(14.2)	1.00(25.4)
3/8	3/8	-T-FJ6N6FJ6	1.31(33.3)	0.66(16.8)	0.69(17.5)	0.81(20.6)	0.28(7.1)	0.56(14.2)	1.11(28.2)
1/2	3/8	-T-FJ8N6FJ8	1.42(36.1)	0.90(22.9)	0.87(22.2)	0.81(20.6)	0.38(9.7)	0.56(14.2)	1.11(28.2)
1/2	1/2	-T-FJ8N8FJ8	1.42(36.1)	0.90(22.9)	0.87(22.2)	0.81(20.6)	0.41(10.4)	0.75(19.1)	1.3(33.0)
5/8	1/2	-T-FJ10N8FJ10	1.50(38.1)	0.96(24.4)	1.00(25.4)	0.94(23.8)	0.47(11.9)	0.75(19.1)	1.41(35.8)
3/4	3/4	-T-FJ12N12FJ12	1.57(39.9)	0.96(24.4)	1.13(28.6)	1.06(27.0)	0.62(15.7)	0.75(19.1)	1.45(36.8)
7/8	3/4	-T-FJ14N12FJ14	1.88(47.8)	1.02(25.9)	1.25(31.8)	1.37(34.9)	0.62(15.7)	0.75(19.1)	1.87(47.5)
1	3/4	-T-FJ16N12FJ16	1.94(49.3)	1.23(31.2)	1.50(38.1)	1.37(34.9)	0.62(15.7)	0.75(19.1)	1.87(47.5)
1	1	-T-FJ16N16FJ16	1.94(49.3)	1.23(31.2)	1.50(38.1)	1.37(34.9)	0.88(22.4)	0.94(23.9)	1.84(46.7)

公制 Tube 管			NPT 螺纹						
T-Tube 管外径 (mm)	P-NPT 尺寸	基本 订购号	尺寸, mm (in.)						
			L	C	G	F	E	B	Lx
6	1/8	-T-MJ6N2MJ6	27.0(1.06)	15.3(0.60)	14.0(0.55)	12.7(0.50)	4.8(0.19)	9.7(0.38)	18.0(0.71)
6	1/4	-T-MJ6N4MJ6	27.0(1.06)	15.3(0.60)	14.0(0.55)	12.7(0.50)	4.8(0.19)	14.2(0.56)	23.4(0.92)
8	1/8	-T-MJ8N2MJ8	29.9(1.18)	16.2(0.64)	16.0(0.63)	15.9(0.63)	4.8(0.19)	9.7(0.38)	20.8(0.82)
8	1/4	-T-MJ8N4MJ8	29.9(1.18)	16.2(0.64)	16.0(0.63)	15.9(0.63)	6.4(0.25)	14.2(0.56)	25.4(1.00)
10	1/4	-T-MJ10N4MJ10	33.5(1.32)	17.2(0.68)	19.0(0.75)	20.6(0.81)	7.1(0.28)	14.2(0.56)	28.2(1.11)
10	1/2	-T-MJ10N8MJ10	33.5(1.32)	17.2(0.68)	19.0(0.75)	20.6(0.81)	7.9(0.31)	19.1(0.75)	33.0(1.30)
12	1/4	-T-MJ12N4MJ12	36.0(1.42)	22.8(0.90)	22.0(0.87)	20.6(0.81)	7.1(0.28)	14.2(0.56)	28.2(1.11)
12	3/8	-T-MJ12N6MJ12	36.0(1.42)	22.8(0.90)	22.0(0.87)	20.6(0.81)	9.5(0.37)	14.2(0.56)	28.2(1.11)
12	1/2	-T-MJ12N8MJ12	36.0(1.42)	22.8(0.90)	22.0(0.87)	20.6(0.81)	9.5(0.37)	19.1(0.75)	33.0(1.30)
16	1/2	-T-MJ16N8MJ16	38.0(1.50)	24.4(0.96)	25.0(0.98)	23.8(0.94)	11.9(0.47)	19.1(0.75)	35.0(1.38)

▶ 支管阳螺纹位置可调卡套三通

ISO 平行螺纹

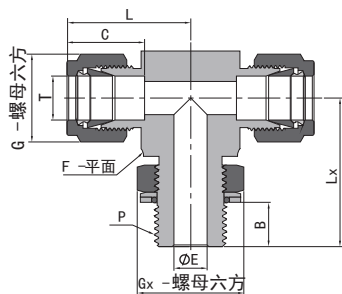

◆ 尺寸“E”为最小公称孔口,此孔口在管螺纹端、直螺纹端可能会更大。

英制 Tube 管			ISO 平行螺纹 (SBP)							
T-Tube 管外径 (in.)	P-ISO平行 螺纹尺寸	基本订购号	尺寸, in. (mm)							
			L	B	C	E	G	F	Lx	Gx
1/4	1/8	-T-FJ4FJ4SBP2	1.06(26.9)	0.26(6.6)	0.60(15.2)	0.16(4.1)	0.56(14.3)	0.50(12.7)	1.04(26.4)	0.56(14.3)
1/4	1/4	-T-FJ4FJ4SBP4	1.14(29.0)	0.35(9.0)	0.60(15.2)	0.19(4.8)	0.56(14.3)	0.63(15.9)	1.27(32.3)	0.75(19.1)
3/8	1/4	-T-FJ6FJ6SBP4	1.20(30.5)	0.35(9.0)	0.66(16.8)	0.23(5.8)	0.69(17.5)	0.63(15.9)	1.27(32.3)	0.75(19.1)
1/2	3/8	-T-FJ8FJ8SBP6	1.42(36.1)	0.37(9.4)	0.90(22.9)	0.31(7.9)	0.87(22.2)	0.81(20.6)	1.46(37.1)	0.87(22.2)
1/2	1/2	-T-FJ8FJ8SBP8	1.50(38.1)	0.51(13.0)	0.90(22.9)	0.41(10.4)	0.87(22.2)	0.94(23.8)	1.71(43.4)	1.06(27.0)
5/8	1/2	-T-FJ10FJ10SBP8	1.50(38.1)	0.51(13.0)	0.96(24.4)	0.47(11.9)	1.00(25.4)	0.94(23.8)	1.71(43.4)	1.06(27.0)
3/4	1/2	-T-FJ12FJ12SBP8	1.57(39.9)	0.51(13.0)	0.96(24.4)	0.47(11.9)	1.13(28.6)	1.06(27.0)	1.78(45.2)	1.06(27.0)
3/4	3/4	-T-FJ12FJ12SBP12	1.57(39.9)	0.51(13.0)	0.96(24.4)	0.62(15.7)	1.13(28.6)	1.06(27.0)	1.92(48.8)	1.37(34.9)
1	1	-T-FJ16FJ16SBP16	1.93(49.0)	0.52(13.2)	1.23(31.2)	0.78(19.8)	1.50(38.1)	1.37(34.9)	2.11(53.6)	1.63(41.3)

公制 Tube 管			ISO 平行螺纹 (SBP)							
T-Tube 管外径 (mm)	P-ISO平行 螺纹尺寸	基本订购号	尺寸, mm (in.)							
			L	B	C	E	G	F	Lx	Gx
6	1/8	-T-MJ6MJ6SBP2	27.0(1.06)	6.6(0.26)	15.3(0.60)	4.0(0.16)	14.0(0.55)	12.7(0.50)	26.4(1.04)	14.3(0.56)
6	1/4	-T-MJ6MJ6SBP4	29.0(1.14)	9.0(0.35)	15.3(0.60)	4.8(0.19)	14.0(0.55)	15.9(0.63)	32.2(1.27)	19.1(0.75)
8	1/8	-T-MJ8MJ8SBP2	28.8(1.13)	6.6(0.26)	16.2(0.64)	4.0(0.16)	16.0(0.63)	14.3(0.56)	27.5(1.08)	14.3(0.56)
8	1/4	-T-MJ8MJ8SBP4	29.9(1.18)	9.0(0.35)	16.2(0.64)	5.9(0.23)	16.0(0.63)	15.9(0.63)	32.2(1.27)	19.1(0.75)
10	1/4	-T-MJ10MJ10SBP4	33.5(1.32)	9.0(0.35)	17.2(0.68)	5.9(0.23)	19.0(0.75)	20.6(0.81)	35.1(1.38)	19.1(0.75)
12	3/8	-T-MJ12MJ12SBP6	36.0(1.42)	9.4(0.37)	22.8(0.90)	7.9(0.31)	22.0(0.87)	20.6(0.81)	37.1(1.46)	22.2(0.87)
12	1/2	-T-MJ12MJ12SBP8	38.0(1.50)	13.0(0.51)	22.8(0.90)	9.5(0.37)	22.0(0.87)	23.8(0.94)	43.5(1.71)	27.0(1.06)

► 支管阳螺纹位置可调卡套三通

SAE/MS 直螺纹

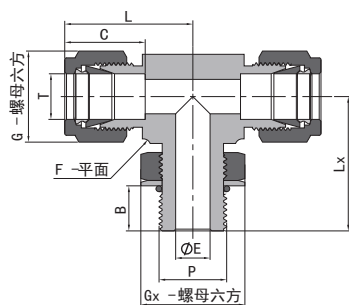

- ◆ 尺寸"E"为最小公称孔口,此孔口在管螺纹端、直螺纹端可能会更大。
- ◆ 转接至 SAE J1926-1、ISO 11926-1 和 MS 16142 直螺纹凸台。

英制 Tube 管				SAE/MS 直螺纹								
T-Tube 管外径 (in.)	P-SAE 名义尺寸	P-SAE/MS 螺纹规格	基本订购号	尺寸, in. (mm)								
				L	B	C	E	G	F	Lx	Gx	
1/4	4	7/16-20	-T-FJ4FJ4SOT7	1.12(28.5)	0.39(9.9)	0.60(15.2)	0.19(4.8)	0.56(14.3)	0.50(12.7)	1.06(27.0)	0.56(14.3)	
3/8	6	9/16-18	-T-FJ6FJ6SOT9	1.26(32.0)	0.44(11.2)	0.66(16.8)	0.28(7.1)	0.69(17.5)	0.63(15.9)	1.27(32.3)	0.69(17.5)	
1/2	8	3/4-16	-T-FJ8FJ8SOT12	1.48(37.6)	0.50(12.7)	0.90(22.9)	0.41(10.4)	0.87(22.2)	0.81(20.6)	1.49(37.8)	0.87(22.2)	
3/4	12	1 1/16-12	-T-FJ12FJ12SOT17	1.63(41.4)	0.66(16.8)	0.96(24.4)	0.62(15.7)	1.13(28.6)	1.06(27.0)	1.92(48.8)	1.25(31.8)	
1	16	1 5/16-12	-T-FJ16FJ16SOT21	1.99(50.5)	0.66(16.8)	1.23(31.2)	0.88(22.4)	1.50(38.1)	1.37(34.9)	2.11(53.6)	1.50(38.1)	
1 1/4	20	1 5/8-12	-T-FJ20FJ20SOT26	2.67(67.8)	0.66(16.8)	1.62(41.1)	1.09(27.7)	1.87(47.6)	1.69(42.9)	2.29(58.2)	1.87(47.6)	
1 1/2	24	1 7/8-12	-T-FJ24FJ24SOT30	3.07(78.0)	0.66(16.8)	1.97(50.0)	1.34(34.0)	2.25(57.2)	2.00(50.8)	2.38(60.5)	2.13(54.0)	

► 支管阳螺纹位置可调卡套三通

SAE/MS 直螺纹

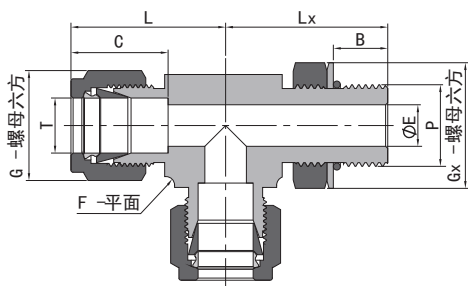

- ◆ 尺寸"E"为最小公称孔口,此孔口在管螺纹端、直螺纹端可能会更大。
- ◆ 转接至 SAE J1926-1、ISO 11926-1 和 MS 16142 直螺纹凸台。

英制 Tube 管				SAE/MS 直螺纹								
T-Tube 管外径 (in.)	P-SAE 名义尺寸	P-SAE/MS 螺纹规格	基本订购号	尺寸, in. (mm)								
				L	B	C	E	G	F	Lx	Gx	
1/4	4	7/16-20	-T-FJ4SOT7FJ4	1.12(28.5)	0.39(9.9)	0.60(15.2)	0.19(4.8)	0.56(14.3)	0.50(12.7)	1.06(27.0)	0.56(14.3)	
3/8	6	9/16-18	-T-FJ6SOT9FJ6	1.26(32.0)	0.44(11.2)	0.66(16.8)	0.28(7.1)	0.69(17.5)	0.63(15.9)	1.27(32.3)	0.69(17.5)	
1/2	8	3/4-16	-T-FJ8SOT12FJ8	1.48(37.6)	0.50(12.7)	0.90(22.9)	0.41(10.4)	0.87(22.2)	0.81(20.6)	1.49(37.8)	0.87(22.2)	
3/4	12	1 1/16-12	-T-FJ12SOT17FJ12	1.63(41.4)	0.66(16.8)	0.96(24.4)	0.62(15.7)	1.25(31.75)	1.06(27.0)	1.92(48.8)	1.25(31.8)	
1	16	1 5/16-12	-T-FJ16SOT21FJ16	1.99(50.5)	0.66(16.8)	1.23(31.2)	0.88(22.4)	1.50(38.1)	1.37(34.9)	2.11(53.6)	1.50(38.1)	
1 1/4	20	1 5/8-12	-T-FJ20SOT26FJ20	2.67(67.8)	0.66(16.8)	1.62(41.1)	1.09(27.7)	1.87(47.6)	1.69(42.9)	2.29(58.2)	1.87(47.6)	
1 1/2	24	1 7/8-12	-T-FJ24SOT30FJ24	3.07(78.0)	0.66(16.8)	1.97(50.0)	1.34(34.0)	2.25(57.2)	2.00(50.8)	2.38(60.5)	2.13(54.0)	

▶ 主管阳螺纹位置可调卡套三通

ISO 平行螺纹

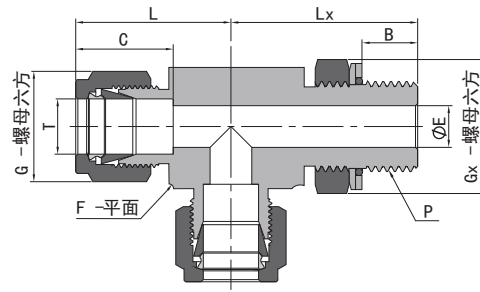

◆ 尺寸"E"为最小公称孔口,此孔口在管螺纹端、直螺纹端可能会更大。

英制 Tube 管			ISO 平行螺纹 (SBP)							
T-Tube 管外径 (in.)	P-ISO平行 螺纹尺寸	基本 订购号	尺寸, in. (mm)							
			L	B	C	E	G	F	Lx	Gx
1/4	1/8	-T-FJ4SBP2FJ4	1.06(26.9)	0.26(6.6)	0.60(15.2)	0.16(4.1)	0.56(14.3)	0.50(12.7)	1.04(26.4)	0.56(14.3)
1/4	1/4	-T-FJ4SBP4FJ4	1.14(29.0)	0.35(9.0)	0.60(15.2)	0.19(4.8)	0.56(14.3)	0.63(15.9)	1.27(32.3)	0.75(19.1)
3/8	1/4	-T-FJ6SBP4FJ6	1.20(30.5)	0.35(9.0)	0.66(16.8)	0.23(5.8)	0.69(17.5)	0.63(15.9)	1.27(32.3)	0.75(19.1)
1/2	3/8	-T-FJ8SBP8FJ6	1.42(36.1)	0.37(9.4)	0.90(22.9)	0.31(7.9)	0.87(22.2)	0.81(20.6)	1.46(37.1)	0.87(22.2)
1/2	1/2	-T-FJ8SBP8FJ8	1.50(38.1)	0.51(13.0)	0.90(22.9)	0.41(10.4)	0.87(22.2)	0.94(23.8)	1.71(43.4)	1.06(27.0)
5/8	1/2	-T-FJ10SBP8FJ10	1.50(38.1)	0.51(13.0)	0.96(24.4)	0.47(11.9)	1.00(25.4)	0.94(23.8)	1.71(43.4)	1.06(27.0)
3/4	1/2	-T-FJ12SBP8FJ12	1.57(39.9)	0.51(13.0)	0.96(24.4)	0.47(11.9)	1.13(28.6)	1.06(27.0)	1.78(45.2)	1.06(27.0)
3/4	3/4	-T-FJ12SBP12FJ12	1.57(39.9)	0.51(13.0)	0.96(24.4)	0.62(15.7)	1.13(28.6)	1.06(27.0)	1.92(48.8)	1.37(34.9)
1	1	-T-FJ16SBP16FJ16	1.93(49.0)	0.52(13.2)	1.23(31.2)	0.78(19.8)	1.50(38.1)	1.37(34.9)	2.11(53.6)	1.63(41.3)

公制 Tube 管			ISO 平行螺纹 (SBP)							
T-Tube 管外径 (mm)	P-ISO平行 螺纹尺寸	基本 订购号	尺寸, mm (in.)							
			L	B	C	E	G	F	Lx	Gx
6	1/8	-T-MJ6SBP2MJ6	27.0(1.06)	6.6(0.26)	15.3(0.60)	4.0(0.16)	14.0(0.55)	12.7(0.50)	26.4(1.04)	14.3(0.56)
6	1/4	-T-MJ6SBP4MJ6	29.0(1.14)	9.0(0.35)	15.3(0.60)	4.8(0.19)	14.0(0.55)	15.9(0.63)	32.2(1.27)	19.1(0.75)
8	1/8	-T-MJ8SBP2MJ8	28.8(1.13)	6.6(0.26)	16.2(0.64)	4.0(0.16)	16.0(0.63)	14.3(0.56)	27.5(1.08)	14.3(0.56)
8	1/4	-T-MJ8SBP4MJ8	29.9(1.18)	9.0(0.35)	16.2(0.64)	5.9(0.23)	16.0(0.63)	15.9(0.63)	32.2(1.27)	19.1(0.75)
10	1/4	-T-MJ10SBP4MJ10	33.5(1.32)	9.0(0.35)	17.2(0.68)	5.9(0.23)	19.0(0.75)	20.6(0.81)	35.1(1.38)	19.1(0.75)
12	3/8	-T-MJ12SBP6MJ12	36.0(1.42)	9.4(0.37)	22.8(0.90)	7.9(0.31)	22.0(0.87)	20.6(0.81)	37.1(1.46)	22.2(0.87)
12	1/2	-T-MJ12SBP8MJ12	38.0(1.50)	13.0(0.51)	22.8(0.90)	9.5(0.37)	22.0(0.87)	23.8(0.94)	43.5(1.71)	27.0(1.06)

▶ 支管阴螺纹卡套三通

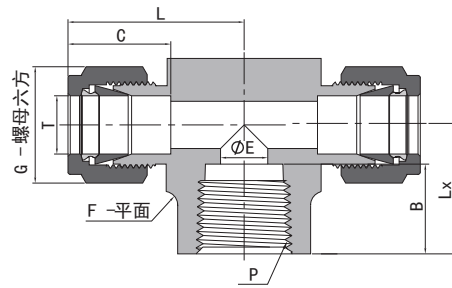

英制 Tube 管			NPT 螺纹						
T-Tube 管外径 (in.)	P-NPT 尺寸	基本 订购号	尺寸, in. (mm)						
			L	C	G	F	E	B	Lx
1/8	1/8	-T-FJ2FJ2FN2	0.97(24.6)	0.50(12.7)	0.44(11.1)	0.50(12.7)	0.09(2.3)	0.41(10.4)	0.75(19.1)
3/16	1/8	-T-FJ3FJ3FN2	1.01(25.7)	0.54(13.7)	0.50(12.7)	0.50(12.7)	0.12(3.0)	0.41(10.4)	0.75(19.1)
1/4	1/8	-T-FJ4FJ4FN2	1.06(26.9)	0.60(15.2)	0.56(14.3)	0.50(12.7)	0.19(4.8)	0.41(10.4)	0.75(19.1)
1/4	1/4	-T-FJ4FJ4FN4	1.17(29.7)	0.60(15.2)	0.56(14.3)	0.69(17.5)	0.19(4.8)	0.59(15.0)	0.88(22.4)
5/16	1/8	-T-FJ5FJ5FN2	1.17(29.7)	0.64(16.2)	0.63(15.9)	0.63(15.9)	0.25(6.4)	0.41(10.4)	0.75(19.1)
3/8	1/4	-T-FJ6FJ6FN4	1.23(31.2)	0.66(16.8)	0.69(17.5)	0.69(17.5)	0.28(7.1)	0.59(15.0)	0.88(22.4)
3/8	3/8	-T-FJ6FJ6FN6	1.31(33.3)	0.66(16.8)	0.69(17.5)	0.81(20.6)	0.28(7.1)	0.59(15.0)	0.88(22.4)
3/8	1/2	-T-FJ6FJ6FN8	1.42(36.1)	0.66(16.8)	0.69(17.5)	1.00(25.4)	0.28(7.1)	0.78(19.8)	1.12(28.4)
1/2	1/4	-T-FJ8FJ8FN4	1.42(36.1)	0.90(22.9)	0.87(22.2)	0.81(20.6)	0.41(10.4)	0.59(15.0)	0.88(22.4)
1/2	3/8	-T-FJ8FJ8FN6	1.42(36.1)	0.90(22.9)	0.87(22.2)	0.81(20.6)	0.41(10.4)	0.59(15.0)	0.88(22.4)
1/2	1/2	-T-FJ8FJ8FN8	1.53(38.9)	0.90(22.9)	0.87(22.2)	1.00(25.4)	0.41(10.4)	0.78(19.8)	1.12(28.4)
5/8	1/2	-T-FJ10FJ10FN8	1.53(38.9)	0.96(24.4)	1.00(25.4)	1.00(25.4)	0.50(12.7)	0.78(19.8)	1.12(28.4)
3/4	3/4	-T-FJ12FJ12FN12	1.76(44.7)	0.96(24.4)	1.13(28.6)	1.37(34.9)	0.62(15.7)	0.81(20.6)	1.25(31.8)
7/8	3/4	-T-FJ14FJ14FN12	1.76(44.7)	1.02(25.9)	1.25(31.8)	1.37(34.9)	0.72(18.3)	0.81(20.6)	1.25(31.8)
1	3/4	-T-FJ16FJ16FN12	1.93(49.0)	1.23(31.2)	1.50(38.1)	1.37(34.9)	0.88(22.4)	0.81(20.6)	1.25(31.8)
1	1	-T-FJ16FJ16FN16	2.11(53.6)	1.23(31.2)	1.50(38.1)	1.69(42.9)	0.88(22.4)	1.00(25.4)	1.50(38.1)

公制 Tube 管			NPT 螺纹						
T-Tube 管外径 (mm)	P-NPT 尺寸	基本 订购号	尺寸, mm (in.)						
			L	C	G	F	E	B	Lx
6	1/8	-T-MJ6MJ6FN2	27.0(1.06)	15.3(0.60)	14.0(0.55)	12.7(0.50)	4.8(0.19)	10.4(0.41)	19.0(0.75)
6	1/4	-T-MJ6MJ6FN4	29.8(1.17)	15.3(0.60)	14.0(0.55)	17.5(0.69)	4.8(0.19)	15.0(0.59)	22.4(0.88)
8	1/8	-T-MJ8MJ8FN2	29.9(1.18)	16.2(0.64)	16.0(0.63)	15.9(0.63)	6.4(0.25)	10.4(0.41)	19.0(0.75)
8	1/4	-T-MJ8MJ8FN4	30.6(1.2)	16.2(0.64)	16.0(0.63)	17.5(0.69)	6.4(0.25)	15.0(0.59)	22.4(0.88)
10	1/4	-T-MJ10MJ10FN4	33.5(1.32)	17.2(0.68)	19.0(0.75)	20.6(0.81)	7.9(0.31)	15.0(0.59)	22.4(0.88)
12	1/8	-T-MJ12MJ12FN2	36.0(1.42)	22.8(0.90)	22.0(0.87)	20.6(0.81)	6.4(0.25)	10.4(0.41)	22.3(0.88)
12	1/4	-T-MJ12MJ12FN4	36.0(1.42)	22.8(0.90)	22.0(0.87)	20.6(0.81)	9.5(0.37)	15.0(0.59)	22.4(0.88)
12	3/8	-T-MJ12MJ12FN6	36.0(1.42)	22.8(0.90)	22.0(0.87)	20.6(0.81)	9.5(0.37)	15.0(0.59)	22.4(0.88)
12	1/2	-T-MJ12MJ12FN8	38.8(1.53)	22.8(0.90)	22.0(0.87)	25.4(1.00)	9.5(0.37)	19.8(0.78)	28.5(1.12)
16	1/2	-T-MJ16MJ16FN8	38.8(1.53)	24.4(0.96)	25.0(0.98)	25.4(1.00)	12.7(0.50)	19.8(0.78)	28.4(1.12)

▶ 主管阴螺纹卡套三通

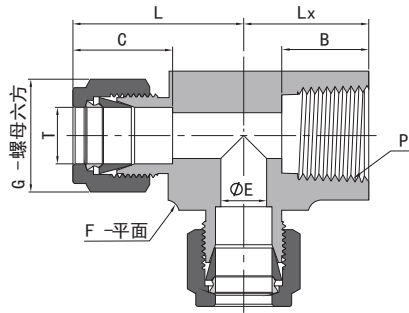

英制 Tube 管			NPT 螺纹						
T-Tube 管外径 (in.)	P-NPT 尺寸	基本 订购号	尺寸, in. (mm)						
			L	C	G	F	E	B	Lx
1/8	1/8	-T-FJ2FN2FJ2	0.97(24.6)	0.50(12.7)	0.44(11.1)	0.50(12.7)	0.09(2.3)	0.41(10.4)	0.75(19.1)
3/16	1/8	-T-FJ3FN2FJ3	1.01(25.7)	0.54(13.7)	0.50(12.7)	0.50(12.7)	0.12(3.0)	0.41(10.4)	0.75(19.1)
1/4	1/8	-T-FJ4FN2FJ4	1.06(26.9)	0.60(15.2)	0.56(14.3)	0.50(12.7)	0.19(4.8)	0.41(10.4)	0.75(19.1)
1/4	1/4	-T-FJ4FN4FJ4	1.17(29.7)	0.60(15.2)	0.56(14.3)	0.69(17.5)	0.19(4.8)	0.59(15.0)	0.88(22.4)
5/16	1/8	-T-FJ5FN2FJ5	1.17(29.7)	0.64(16.2)	0.63(15.9)	0.63(15.9)	0.25(6.4)	0.41(10.4)	0.75(19.1)
3/8	1/4	-T-FJ6FN4FJ6	1.23(31.2)	0.66(16.8)	0.69(17.5)	0.69(17.5)	0.28(7.1)	0.59(15.0)	0.88(22.4)
1/2	1/4	-T-FJ8FN4FJ8	1.42(36.1)	0.90(22.9)	0.87(22.2)	0.81(20.6)	0.41(10.4)	0.59(15.0)	0.88(22.4)
1/2	3/8	-T-FJ8FN6FJ8	1.42(36.1)	0.90(22.9)	0.87(22.2)	0.81(20.6)	0.41(10.4)	0.59(15.0)	0.88(22.4)
1/2	1/2	-T-FJ8FN8FJ8	1.57(39.9)	0.90(22.9)	0.87(22.2)	1.06(27.0)	0.41(10.4)	0.78(19.8)	1.12(28.4)
5/8	1/2	-T-FJ10FN8FJ10	1.57(39.9)	0.96(24.4)	1.00(25.4)	1.06(27.0)	0.50(12.7)	0.78(19.8)	1.12(28.4)
3/4	3/4	-T-FJ12FN12FJ12	1.76(44.7)	0.96(24.4)	1.13(28.6)	1.37(34.9)	0.62(15.7)	0.81(20.6)	1.25(31.8)
7/8	1/2	-T-FJ14FN8FJ14	1.76(44.7)	1.02(25.9)	1.25(31.8)	1.37(34.9)	0.62(15.7)	0.78(19.8)	1.12(28.4)
7/8	3/4	-T-FJ14FN12FJ14	1.76(44.7)	1.02(25.9)	1.25(31.8)	1.37(34.9)	0.72(18.3)	0.81(20.6)	1.25(31.8)
1	3/4	-T-FJ16FN12FJ16	1.93(49.0)	1.23(31.2)	1.50(38.1)	1.37(34.9)	0.88(22.4)	0.81(20.6)	1.25(31.8)
1	1	-T-FJ16FN16FJ16	2.11(53.6)	1.23(31.2)	1.50(38.1)	1.69(42.9)	0.88(22.4)	1.00(25.4)	1.50(38.1)

公制 Tube 管			NPT 螺纹						
T-Tube 管外径 (mm)	P-NPT 尺寸	基本 订购号	尺寸, mm (in.)						
			L	C	G	F	E	B	Lx
6	1/8	-T-MJ6FN2MJ6	27.0(1.06)	15.3(0.60)	14.0(0.55)	12.7(0.50)	4.8(0.19)	10.4(0.41)	19.0(0.75)
6	1/4	-T-MJ6FN4MJ6	29.8(1.17)	15.3(0.60)	14.0(0.55)	17.5(0.69)	4.8(0.19)	15.0(0.59)	22.4(0.88)
8	1/8	-T-MJ8FN2MJ8	29.9(1.18)	16.2(0.64)	16.0(0.63)	15.9(0.63)	6.4(0.25)	10.4(0.41)	19.0(0.75)
8	1/4	-T-MJ8FN4MJ8	30.6(1.20)	16.2(0.64)	16.0(0.63)	17.5(0.69)	6.4(0.25)	15.0(0.59)	22.4(0.88)
10	1/4	-T-MJ10FN4MJ10	33.5(1.32)	17.2(0.68)	19.0(0.75)	20.6(0.81)	7.9(0.31)	15.0(0.59)	22.4(0.88)
12	1/4	-T-MJ12FN4MJ12	36.0(1.42)	22.8(0.90)	22.0(0.87)	20.6(0.81)	9.5(0.37)	15.0(0.59)	22.4(0.88)
12	3/8	-T-MJ12FN6MJ12	36.0(1.42)	22.8(0.90)	22.0(0.87)	20.6(0.81)	9.5(0.37)	15.0(0.59)	23.1(0.91)
12	1/2	-T-MJ12FN8MJ12	38.8(1.53)	22.8(0.90)	22.0(0.87)	25.4(1.00)	9.5(0.37)	19.8(0.78)	28.5(1.12)
16	1/2	-T-MJ16FN8MJ16	39.8(1.57)	24.4(0.96)	25.0(0.98)	27.0(1.06)	12.7(0.50)	19.8(0.78)	28.4(1.12)

▶ 卡套三通

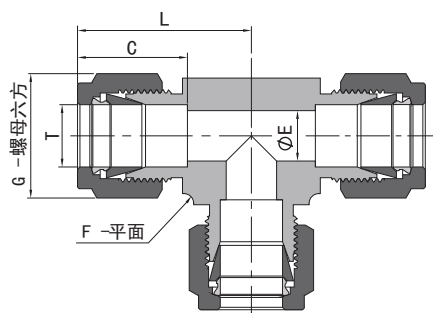

英制 Tube 管						
T-Tube 管外径 (in.)	基本 订购号	尺寸, in. (mm)				
		L	C	G	F	E
1/16	-T-FJ1	0.70(17.8)	0.34(8.6)	0.31(7.9)	0.37(9.5)	0.05(1.3)
1/8	-T-FJ2	0.87(22.2)	0.50(12.7)	0.44(11.1)	0.37(9.5)	0.09(2.3)
3/16	-T-FJ3	0.96(24.4)	0.54(13.7)	0.50(12.7)	0.44(11.1)	0.12(3.0)
1/4	-T-FJ4	1.06(26.9)	0.60(15.2)	0.56(14.3)	0.50(12.7)	0.19(4.8)
5/16	-T-FJ5	1.17(29.7)	0.64(16.2)	0.63(15.9)	0.63(15.9)	0.25(6.4)
3/8	-T-FJ6	1.20(30.5)	0.66(16.8)	0.69(17.5)	0.63(15.9)	0.28(7.1)
1/2	-T-FJ8	1.42(36.1)	0.90(22.9)	0.87(22.2)	0.81(20.6)	0.41(10.4)
5/8	-T-FJ10	1.53(38.9)	0.96(24.4)	1.00(25.4)	1.00(25.4)	0.50(12.7)
3/4	-T-FJ12	1.57(39.9)	0.96(24.4)	1.13(28.6)	1.06(27.0)	0.62(15.7)
7/8	-T-FJ14	1.76(44.7)	1.02(25.9)	1.25(31.8)	1.37(34.9)	0.72(18.3)
1	-T-FJ16	1.93(49.0)	1.23(31.2)	1.50(38.1)	1.37(34.9)	0.88(22.4)
1 1/8	-T-FJ18	2.17(55.1)	1.44(36.7)	1.75(44.5)	1.69(42.9)	0.97(24.6)
1 1/4	-T-FJ20	2.62(66.5)	1.62(41.1)	1.87(47.6)	1.69(42.9)	1.09(27.7)
1 1/2	-T-FJ24	3.07(78.0)	1.97(50.0)	2.25(57.2)	2.00(50.8)	1.34(34.0)

公制 Tube 管						
T-Tube 管外径 (mm)	基本 订购号	尺寸, mm (in.)				
		L	C	G	F	E
2	-T-MJ2	22.3(0.88)	12.9(0.51)	12.0(0.47)	9.5(0.37)	1.7(0.07)
3	-T-MJ3	22.3(0.88)	12.9(0.51)	12.0(0.47)	9.5(0.37)	2.4(0.09)
4	-T-MJ4	25.4(1.00)	13.7(0.54)	12.0(0.47)	12.7(0.50)	2.4(0.09)
6	-T-MJ6	27.0(1.06)	15.3(0.60)	14.0(0.55)	12.7(0.50)	4.8(0.19)
8	-T-MJ8	29.9(1.18)	16.2(0.64)	16.0(0.63)	15.9(0.63)	6.4(0.25)
10	-T-MJ10	31.5(1.24)	17.2(0.68)	19.0(0.75)	17.5(0.69)	7.9(0.31)
12	-T-MJ12	36.0(1.42)	22.8(0.90)	22.0(0.87)	20.6(0.81)	9.5(0.37)
14	-T-MJ14	38.8(1.53)	24.4(0.96)	25.0(0.98)	25.4(1.00)	11.1(0.44)
15	-T-MJ15	38.8(1.53)	24.4(0.96)	25.0(0.98)	25.4(1.00)	11.9(0.47)
16	-T-MJ16	38.8(1.53)	24.4(0.96)	25.0(0.98)	25.4(1.00)	12.7(0.50)
18	-T-MJ18	39.8(1.57)	24.4(0.96)	30.0(1.18)	27.0(1.06)	15.1(0.59)
20	-T-MJ20	44.6(1.76)	26.0(1.02)	32.0(1.26)	34.9(1.37)	15.9(0.63)
22	-T-MJ22	44.6(1.76)	26.0(1.02)	32.0(1.26)	34.9(1.37)	18.3(0.72)
25	-T-MJ25	49.1(1.93)	31.3(1.23)	38.0(1.50)	34.9(1.37)	21.8(0.86)
28	-T-MJ28	64.0(2.52)	36.6(1.44)	46.0(1.81)	42.9(1.69)	21.8(0.86)
30	-T-MJ30	69.9(2.75)	39.6(1.56)	50.0(1.97)	42.9(1.69)	26.2(1.03)
32	-T-MJ32	72.3(2.85)	42.0(1.65)	50.0(1.97)	42.9(1.69)	28.6(1.13)
38	-T-MJ38	84.0(3.31)	49.4(1.94)	60.0(2.36)	50.8(2.00)	33.7(1.33)

▶ 卡套变径三通

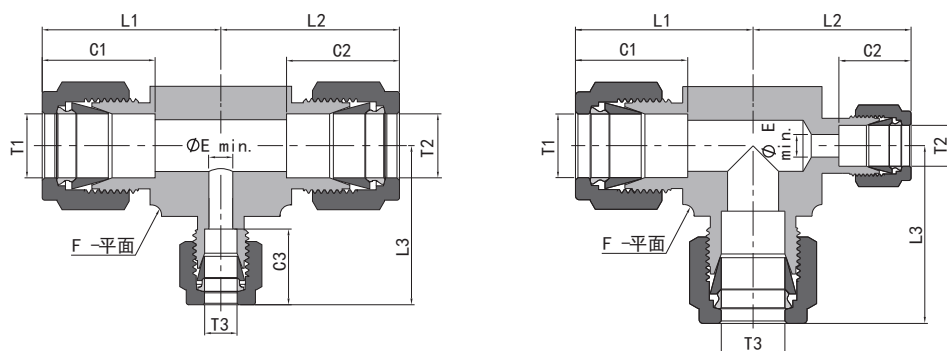

英制 Tube 管											
T1-Tube 管外径 (in.)	T2-Tube 管外径 (in.)	T3-Tube 管外径 (in.)	基本 订购号	尺寸, in. (mm)							
				L1	L2	L3	C1	C2	C3	F	E min.
1/4	1/4	1/8	-T-FJ4FJ4FJ2	1.05(26.7)	1.05(26.7)	0.96(24.4)	0.60(15.2)	0.60(15.2)	0.50(12.7)	0.50(12.7)	0.09(2.3)
3/8	1/4	1/4	-T-FJ6FJ4FJ4	1.20(30.5)	1.14(29.0)	1.14(29.0)	0.66(16.8)	0.60(15.2)	0.60(15.2)	0.63(15.9)	0.19(4.8)
3/8	1/4	3/8	-T-FJ6FJ4FJ6	1.20(30.5)	1.14(29.0)	1.20(30.5)	0.66(16.8)	0.60(15.2)	0.66(16.8)	0.63(15.9)	0.19(4.8)
3/8	3/8	1/4	-T-FJ6FJ6FJ4	1.20(30.5)	1.20(30.5)	1.14(29.0)	0.66(16.8)	0.66(16.8)	0.60(15.2)	0.63(15.9)	0.19(4.8)
1/2	1/4	1/4	-T-FJ8FJ4FJ4	1.42(36.1)	1.22(30.9)	1.22(30.9)	0.90(22.9)	0.60(15.2)	0.60(15.2)	0.81(20.6)	0.19(4.8)
1/2	1/4	1/2	-T-FJ8FJ4FJ8	1.42(36.1)	1.25(31.8)	1.42(36.1)	0.90(22.9)	0.60(15.2)	0.90(22.9)	0.81(20.6)	0.19(4.8)
1/2	3/8	3/8	-T-FJ8FJ6FJ6	1.42(36.1)	1.31(33.3)	1.31(33.3)	0.90(22.9)	0.66(16.8)	0.66(16.8)	0.81(20.6)	0.28(7.1)
1/2	3/8	1/2	-T-FJ8FJ6FJ8	1.42(36.1)	1.31(33.3)	1.42(36.1)	0.90(22.9)	0.66(16.8)	0.90(22.9)	0.81(20.6)	0.28(7.1)
1/2	1/2	1/4	-T-FJ8FJ8FJ4	1.42(36.1)	1.42(36.1)	1.25(31.8)	0.90(22.9)	0.90(22.9)	0.60(15.2)	0.81(20.6)	0.19(4.8)
1/2	1/2	3/8	-T-FJ8FJ8FJ6	1.42(36.1)	1.42(36.1)	1.31(33.3)	0.90(22.9)	0.90(22.9)	0.66(16.8)	0.81(20.6)	0.28(7.1)
5/8	3/8	3/8	-T-FJ10FJ6FJ6	1.53(38.9)	1.42(36.1)	1.42(36.1)	0.96(24.4)	0.66(16.8)	0.66(16.8)	1.00(25.4)	0.28(7.1)
5/8	1/2	1/2	-T-FJ10FJ8FJ8	1.53(38.9)	1.53(38.9)	1.53(38.9)	0.96(24.4)	0.90(22.9)	0.90(22.9)	1.00(25.4)	0.41(10.4)
5/8	5/8	3/8	-T-FJ10FJ10FJ6	1.53(38.9)	1.53(38.9)	1.42(36.1)	0.96(24.4)	0.96(24.4)	0.66(16.8)	1.00(25.4)	0.28(7.1)
5/8	5/8	1/2	-T-FJ10FJ10FJ8	1.53(38.9)	1.53(38.9)	1.53(38.9)	0.96(24.4)	0.96(24.4)	0.90(22.9)	1.00(25.4)	0.41(10.4)
3/4	3/8	3/8	-T-FJ12FJ6FJ6	1.56(39.6)	1.45(36.9)	1.45(36.9)	0.96(24.4)	0.66(16.8)	0.66(16.8)	1.06(27.0)	0.28(7.1)
3/4	1/2	1/2	-T-FJ12FJ8FJ8	1.56(39.6)	1.56(39.6)	1.56(39.6)	0.96(24.4)	0.90(22.9)	0.90(22.9)	1.06(27.0)	0.41(10.4)
3/4	5/8	5/8	-T-FJ12FJ10FJ10	1.56(39.6)	1.56(39.6)	1.56(39.6)	0.96(24.4)	0.96(24.4)	0.96(24.4)	1.06(27.0)	0.50(12.7)
3/4	3/4	1/4	-T-FJ12FJ12FJ4	1.56(39.6)	1.56(39.6)	1.43(36.3)	0.96(24.4)	0.96(24.4)	0.60(15.2)	1.06(27.0)	0.19(4.8)
3/4	3/4	3/8	-T-FJ12FJ12FJ6	1.56(39.6)	1.56(39.6)	1.45(36.9)	0.96(24.4)	0.96(24.4)	0.66(16.8)	1.06(27.0)	0.28(7.1)
3/4	3/4	1/2	-T-FJ12FJ12FJ8	1.56(39.6)	1.56(39.6)	1.56(39.6)	0.96(24.4)	0.96(24.4)	0.90(22.9)	1.06(27.0)	0.41(10.4)
3/4	3/4	5/8	-T-FJ12FJ12FJ10	1.56(39.6)	1.56(39.6)	1.56(39.6)	0.96(24.4)	0.96(24.4)	0.96(24.4)	1.06(27.0)	0.50(12.7)
7/8	3/4	3/4	-T-FJ14FJ12FJ12	1.76(44.7)	1.76(44.7)	1.76(44.7)	1.02(25.9)	0.96(24.4)	0.96(24.4)	1.37(34.9)	0.62(15.7)
7/8	7/8	1/4	-T-FJ14FJ14FJ4	1.76(44.7)	1.76(44.7)	1.59(40.4)	1.02(25.9)	1.02(25.9)	0.60(15.2)	1.37(34.9)	0.19(4.8)
7/8	7/8	3/8	-T-FJ14FJ14FJ6	1.76(44.7)	1.76(44.7)	1.65(41.9)	1.02(25.9)	1.02(25.9)	0.66(16.8)	1.37(34.9)	0.28(7.1)
1	3/8	3/8	-T-FJ16FJ6FJ6	1.94(49.3)	1.65(41.9)	1.65(41.9)	1.23(31.2)	0.66(16.8)	0.66(16.8)	1.37(34.9)	0.28(7.1)
1	1/2	1/2	-T-FJ16FJ8FJ8	1.94(49.3)	1.76(44.7)	1.76(44.7)	1.23(31.2)	0.90(22.9)	0.90(22.9)	1.37(34.9)	0.41(10.4)
1	1/2	1	-T-FJ16FJ8FJ16	1.94(49.3)	1.76(44.7)	1.94(49.3)	1.23(31.2)	0.90(22.9)	1.23(31.2)	1.37(34.9)	0.41(10.4)
1	3/4	1	-T-FJ16FJ12FJ16	1.94(49.3)	1.76(44.7)	1.94(49.3)	1.23(31.2)	0.96(24.4)	1.23(31.2)	1.37(34.9)	0.62(15.7)
1	7/8	7/8	-T-FJ16FJ14FJ14	1.94(49.3)	1.76(44.7)	1.76(44.7)	1.23(31.2)	1.02(25.9)	1.02(25.9)	1.37(34.9)	0.72(18.3)
1	1	1/4	-T-FJ16FJ16FJ4	1.94(49.3)	1.94(49.3)	1.59(40.4)	1.23(31.2)	1.23(31.2)	0.60(15.2)	1.37(34.9)	0.19(4.8)
1	1	3/8	-T-FJ16FJ16FJ6	1.94(49.3)	1.94(49.3)	1.65(41.9)	1.23(31.2)	1.23(31.2)	0.66(16.8)	1.37(34.9)	0.28(7.1)
1	1	1/2	-T-FJ16FJ16FJ8	1.94(49.3)	1.94(49.3)	1.76(44.7)	1.23(31.2)	1.23(31.2)	0.90(22.9)	1.37(34.9)	0.41(10.4)
1	1	5/8	-T-FJ16FJ16FJ10	1.94(49.3)	1.94(49.3)	1.76(44.7)	1.23(31.2)	1.23(31.2)	0.96(24.4)	1.37(34.9)	0.50(12.7)
1	1	3/4	-T-FJ16FJ16FJ12	1.94(49.3)	1.94(49.3)	1.76(44.7)	1.23(31.2)	1.23(31.2)	0.96(24.4)	1.37(34.9)	0.62(15.7)
1	1	7/8	-T-FJ16FJ16FJ14	1.94(49.3)	1.94(49.3)	1.76(44.7)	1.23(31.2)	1.23(31.2)	1.02(25.9)	1.37(34.9)	0.72(18.3)
1 1/4	1 1/4	1	-T-FJ20FJ20FJ16	2.67(67.8)	2.67(67.8)	2.17(55.1)	1.62(41.2)	1.62(41.2)	1.23(31.3)	1.69(42.9)	0.88(22.4)
1 1/2	1 1/2	1	-T-FJ24FJ24FJ16	3.10(78.7)	3.10(78.7)	2.36(60.0)	1.97(50.0)	1.97(50.0)	1.23(31.3)	2.00(50.8)	0.88(22.4)

▶ 卡套变径三通

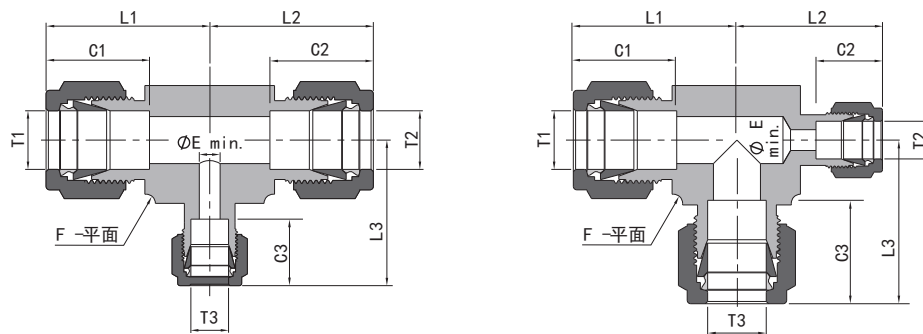

公制 Tube 管												
T1-Tube 管外径 (mm)	T2-Tube 管外径 (mm)	T3-Tube 管外径 (mm)	基本 订购号	尺寸, mm (in.)								
				L1	L2	L3	C1	C2	C3	F	E min.	
3	3	6	-T-MJ3MJ3MJ6	24.7(0.97)	24.7(0.97)	27.0(1.06)	12.9(0.51)	12.9(0.51)	15.3(0.60)	12.7(0.50)	2.4(0.09)	
6	6	3	-T-MJ6MJ6MJ3	27.0(1.06)	27.0(1.06)	24.7(0.97)	15.3(0.60)	15.3(0.60)	12.9(0.51)	12.7(0.50)	2.4(0.09)	
6	6	8	-T-MJ6MJ6MJ8	28.0(1.10)	28.0(1.10)	28.8(1.13)	15.3(0.60)	15.3(0.60)	16.2(0.64)	14.3(0.56)	4.8(0.19)	
8	8	6	-T-MJ8MJ8MJ6	30.0(1.18)	30.0(1.18)	29.0(1.14)	16.2(0.64)	16.2(0.64)	15.3(0.60)	15.9(0.63)	4.8(0.19)	
8	8	12	-T-MJ8MJ8MJ12	35.2(1.39)	35.2(1.39)	36.0(1.42)	16.2(0.64)	16.2(0.64)	22.8(0.90)	20.6(0.81)	6.4(0.25)	
10	10	6	-T-MJ10MJ10MJ6	31.5(1.24)	31.5(1.24)	29.9(1.18)	17.2(0.68)	17.2(0.68)	15.3(0.60)	17.5(0.69)	4.8(0.19)	
10	10	8	-T-MJ10MJ10MJ8	31.5(1.24)	31.5(1.24)	30.7(1.21)	17.2(0.68)	17.2(0.68)	16.2(0.64)	17.5(0.69)	6.4(0.25)	
12	12	6	-T-MJ12MJ12MJ6	36.0(1.42)	36.0(1.42)	31.8(1.25)	22.8(0.90)	22.8(0.90)	15.3(0.60)	20.6(0.81)	4.8(0.19)	
12	12	8	-T-MJ12MJ12MJ8	36.0(1.42)	36.0(1.42)	32.0(1.26)	22.8(0.90)	22.8(0.90)	16.2(0.64)	20.6(0.81)	6.4(0.25)	
12	12	14	-T-MJ12MJ12MJ14	38.0(1.50)	38.0(1.50)	38.0(1.50)	22.8(0.90)	22.8(0.90)	24.4(0.96)	25.4(1.00)	9.5(0.37)	
12	12	18	-T-MJ12MJ12MJ18	39.8(1.57)	39.8(1.57)	39.8(1.57)	22.8(0.90)	22.8(0.90)	24.4(0.96)	27.0(1.06)	9.5(0.37)	
14	14	8	-T-MJ14MJ14MJ8	38.0(1.50)	38.0(1.50)	35.5(1.40)	24.4(0.96)	24.4(0.96)	16.2(0.64)	25.4(1.00)	6.4(0.25)	
14	14	10	-T-MJ14MJ14MJ10	38.0(1.50)	38.0(1.50)	36.7(1.44)	24.4(0.96)	24.4(0.96)	17.2(0.68)	25.4(1.00)	7.9(0.31)	
15	15	12	-T-MJ15MJ15MJ12	38.8(1.53)	38.8(1.53)	38.8(1.53)	24.4(0.96)	24.4(0.96)	22.8(0.90)	25.4(1.00)	9.5(0.37)	
16	8	16	-T-MJ16MJ8MJ16	38.8(1.53)	35.5(1.40)	38.8(1.53)	24.4(0.96)	16.2(0.64)	24.4(0.96)	25.4(1.00)	6.4(0.25)	
16	16	12	-T-MJ16MJ16MJ12	38.8(1.53)	38.8(1.53)	38.9(1.53)	24.4(0.96)	24.4(0.96)	22.8(0.90)	25.4(1.00)	9.5(0.37)	
18	18	8	-T-MJ18MJ18MJ8	39.8(1.57)	39.8(1.57)	39.0(1.54)	24.4(0.96)	24.4(0.96)	16.2(0.64)	27.0(1.06)	6.4(0.25)	
18	18	10	-T-MJ18MJ18MJ10	39.8(1.57)	39.8(1.57)	37.4(1.47)	24.4(0.96)	24.4(0.96)	17.2(0.68)	27.0(1.06)	7.9(0.31)	
18	18	12	-T-MJ18MJ18MJ12	39.8(1.57)	39.8(1.57)	39.8(1.57)	24.4(0.96)	24.4(0.96)	22.8(0.90)	27.0(1.06)	9.5(0.37)	
18	18	14	-T-MJ18MJ18MJ14	39.8(1.57)	39.8(1.57)	39.8(1.57)	24.4(0.96)	24.4(0.96)	24.4(0.96)	27.0(1.06)	11.1(0.44)	
20	20	14	-T-MJ20MJ20MJ14	44.6(1.76)	44.6(1.76)	44.6(1.76)	26.0(1.02)	26.0(1.02)	24.4(0.96)	34.9(1.37)	11.1(0.44)	
22	22	12	-T-MJ22MJ22MJ12	44.6(1.76)	44.6(1.76)	44.6(1.76)	26.0(1.02)	26.0(1.02)	22.8(0.90)	34.9(1.37)	9.5(0.37)	
25	25	12	-T-MJ25MJ25MJ12	49.1(1.93)	49.1(1.93)	44.7(1.76)	31.3(1.23)	31.3(1.23)	22.8(0.90)	34.9(1.37)	9.5(0.37)	

▶ 卡套四通

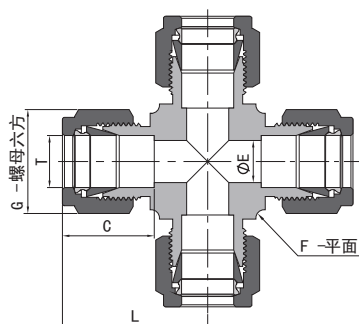

英制 Tube 管						
T-Tube 管外径 (in.)	基本 订购号	尺寸, in. (mm)				
		L	C	G	F	E
1/8	-C-FJ2	0.88(22.4)	0.50(12.7)	0.44(11.1)	0.37(9.5)	0.09(2.3)
3/16	-C-FJ3	0.96(24.4)	0.54(13.7)	0.50(12.7)	0.44(11.1)	0.12(3.0)
1/4	-C-FJ4	1.06(26.9)	0.60(15.2)	0.56(14.3)	0.50(12.7)	0.19(4.8)
5/16	-C-FJ5	1.17(29.7)	0.64(16.2)	0.63(15.9)	0.63(15.9)	0.25(6.4)
3/8	-C-FJ6	1.20(30.5)	0.66(16.8)	0.69(17.5)	0.63(15.9)	0.28(7.1)
1/2	-C-FJ8	1.42(36.1)	0.90(22.9)	0.87(22.2)	0.81(20.6)	0.41(10.4)
5/8	-C-FJ10	1.53(38.8)	0.96(24.4)	1.00(25.4)	1.00(25.4)	0.50(12.7)
3/4	-C-FJ12	1.57(39.9)	0.96(24.4)	1.13(28.6)	1.06(27.0)	0.62(15.7)
7/8	-C-FJ14	1.76(44.7)	1.02(25.9)	1.25(31.8)	1.37(34.9)	0.72(18.3)
1	-C-FJ16	1.93(49.0)	1.23(31.2)	1.50(38.1)	1.37(34.9)	0.88(22.4)

公制 Tube 管						
T-Tube 管外径 (mm)	基本 订购号	尺寸, mm (in.)				
		L	C	G	F	E
3	-C-MJ3	22.3(0.88)	12.9(0.51)	12.0(0.47)	9.5(0.37)	2.4(0.09)
4	-C-MJ4	25.4(1.00)	13.7(0.54)	12.0(0.47)	12.7(0.50)	2.4(0.09)
6	-C-MJ6	27.0(1.06)	15.3(0.60)	14.0(0.55)	12.7(0.50)	4.8(0.19)
8	-C-MJ8	29.9(1.18)	16.2(0.64)	16.0(0.63)	15.9(0.63)	6.4(0.25)
10	-C-MJ10	33.5(1.32)	17.2(0.68)	19.0(0.75)	20.6(0.81)	7.9(0.31)
12	-C-MJ12	36.0(1.42)	22.8(0.90)	22.0(0.87)	20.6(0.81)	9.5(0.37)
16	-C-MJ16	37.0(1.46)	24.4(0.96)	25.0(0.98)	23.8(0.94)	12.7(0.50)
18	-C-MJ18	38.3(1.51)	24.4(0.96)	30.0(1.18)	27.0(1.06)	15.1(0.59)
20	-C-MJ20	44.6(1.76)	26.0(1.02)	32.0(1.26)	34.9(1.37)	15.9(0.63)
22	-C-MJ22	44.7(1.76)	26.0(1.02)	32.0(1.26)	34.9(1.37)	18.3(0.72)
25	-C-MJ25	49.2(1.94)	31.3(1.23)	38.0(1.50)	34.9(1.37)	21.8(0.86)

▶ 卡套管帽

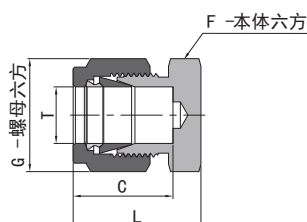

英制 Tube 管					
T-Tube 管外径 (in.)	基本 订购号	尺寸, in. (mm)			
		L	C	G	F
1/16	-TC-FJ1	0.59(15.0)	0.34(8.6)	0.31(7.9)	0.31(7.9)
1/8	-TC-FJ2	0.79(20.1)	0.50(12.7)	0.44(11.1)	0.44(11.1)
3/16	-TC-FJ3	0.84(21.3)	0.54(13.7)	0.50(12.7)	0.44(11.1)
1/4	-TC-FJ4	0.92(23.4)	0.60(15.2)	0.56(14.3)	0.50(12.7)
5/16	-TC-FJ5	0.96(24.4)	0.64(16.3)	0.63(15.9)	0.56(14.3)
3/8	-TC-FJ6	1.01(25.7)	0.66(16.8)	0.69(17.5)	0.63(15.9)
1/2	-TC-FJ8	1.15(29.2)	0.90(22.9)	0.87(22.2)	0.81(20.6)
5/8	-TC-FJ10	1.18(30.0)	0.96(24.4)	1.00(25.4)	0.94(23.8)
3/4	-TC-FJ12	1.24(31.5)	0.96(24.4)	1.13(28.6)	1.06(27.0)
7/8	-TC-FJ14	1.34(34.0)	1.02(25.9)	1.25(31.8)	1.19(30.2)
1	-TC-FJ16	1.51(38.4)	1.23(31.2)	1.50(38.1)	1.37(34.9)
1 1/8	-TC-FJ18	1.51(38.4)	1.44(36.7)	1.75(44.5)	1.63(41.3)
1 1/4	-TC-FJ20	2.10(53.3)	1.62(41.1)	1.87(47.6)	1.75(44.5)
1 1/2	-TC-FJ24	2.54(64.5)	1.97(50.0)	2.25(57.2)	2.13(54.0)

公制 Tube 管					
T-Tube 管外径 (mm)	基本 订购号	尺寸, mm (in.)			
		L	C	G	F
2	-TC-MJ2	20.1(0.79)	12.9(0.51)	12.0(0.47)	12.0(0.47)
3	-TC-MJ3	20.1(0.79)	12.9(0.51)	12.0(0.47)	12.0(0.47)
4	-TC-MJ4	21.3(0.84)	13.7(0.54)	12.0(0.47)	12.0(0.47)
6	-TC-MJ6	23.1(0.91)	15.3(0.60)	14.0(0.55)	14.0(0.55)
8	-TC-MJ8	24.5(0.96)	16.2(0.64)	16.0(0.63)	15.0(0.59)
10	-TC-MJ10	26.6(1.05)	17.2(0.68)	19.0(0.75)	18.0(0.71)
12	-TC-MJ12	29.1(1.15)	22.8(0.90)	22.0(0.87)	22.0(0.87)
14	-TC-MJ14	29.9(1.18)	24.4(0.96)	25.0(0.98)	24.0(0.94)
15	-TC-MJ15	29.9(1.18)	24.4(0.96)	25.0(0.98)	24.0(0.94)
16	-TC-MJ16	29.9(1.18)	24.4(0.96)	25.0(0.98)	24.0(0.94)
18	-TC-MJ18	31.4(1.24)	24.4(0.96)	30.0(1.18)	27.0(1.06)
20	-TC-MJ20	34.0(1.34)	26.0(1.02)	32.0(1.26)	30.0(1.18)
22	-TC-MJ22	34.0(1.34)	26.0(1.02)	32.0(1.26)	30.0(1.18)
25	-TC-MJ25	38.5(1.52)	31.3(1.23)	38.0(1.50)	35.0(1.38)
28	-TC-MJ28	48.5(1.91)	36.6(1.44)	46.0(1.81)	41.0(1.61)
30	-TC-MJ30	53.4(2.10)	39.6(1.56)	50.0(1.97)	46.0(1.81)
32	-TC-MJ32	55.8(2.20)	42.0(1.65)	50.0(1.97)	46.0(1.81)
38	-TC-MJ38	65.4(2.57)	49.4(1.94)	60.0(2.36)	55.0(2.17)

▶ 卡套堵头

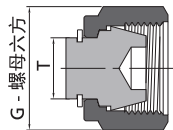

英制 Tube管		
T-Tube 管外径 (in.)	基本 订购号	尺寸 in. (mm)
		G
1/16	-TP-FJ1	0.31(7.9)
1/8	-TP-FJ2	0.44(11.1)
3/16	-TP-FJ3	0.50(12.7)
1/4	-TP-FJ4	0.56(14.3)
5/16	-TP-FJ5	0.63(15.9)
3/8	-TP-FJ6	0.69(17.5)
1/2	-TP-FJ8	0.87(22.2)
5/8	-TP-FJ10	1.00(25.4)
3/4	-TP-FJ12	1.13(28.6)
7/8	-TP-FJ14	1.25(31.8)
1	-TP-FJ16	1.50(38.1)
1 1/4	-TP-FJ20	1.87(47.6)
1 1/2	-TP-FJ24	2.25(57.2)

公制 Tube管		
T-Tube 管外径 (mm)	基本 订购号	尺寸 mm(in.)
		G
2	-TP-MJ2	12.0(0.47)
3	-TP-MJ3	12.0(0.47)
4	-TP-MJ4	12.0(0.47)
6	-TP-MJ6	14.0(0.55)
8	-TP-MJ8	16.0(0.63)
10	-TP-MJ10	19.0(0.75)
12	-TP-MJ12	22.0(0.87)
14	-TP-MJ14	25.0(0.98)
15	-TP-MJ15	25.0(0.98)
16	-TP-MJ16	25.0(0.98)
18	-TP-MJ18	30.0(1.18)
20	-TP-MJ20	32.0(1.26)
22	-TP-MJ22	32.0(1.26)
25	-TP-MJ25	38.0(1.50)
28	-TP-MJ28	46.0(1.81)
30	-TP-MJ30	50.0(1.97)
32	-TP-MJ32	50.0(1.97)
38	-TP-MJ38	60.0(2.36)

▶ 排放保护器

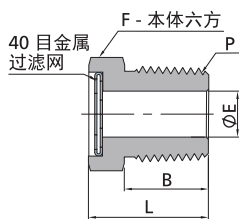

◆ 40 目 300 系列不锈钢过滤网组件

NPT 螺纹					
P-NPT 尺寸	基本 订购号	尺寸 in. (mm)			
		L	F	B	E
1/8	-VP-N2	0.56(14.2)	0.50(12.7)	0.38(9.7)	0.19(4.8)
1/4	-VP-N4	0.78(19.8)	0.56(14.3)	0.56(14.2)	0.28(7.1)
3/8	-VP-N6	0.81(20.6)	0.69(17.5)	0.56(14.2)	0.41(10.4)
1/2	-VP-N8	1.03(26.2)	0.87(22.2)	0.75(19.1)	0.50(12.7)
3/4	-VP-N12	1.06(26.9)	1.06(27.0)	0.76(19.2)	0.72(18.3)
1	-VP-N16	1.37(34.8)	1.37(34.9)	0.94(23.9)	0.88(22.4)

▶ 卡套松套法兰接头

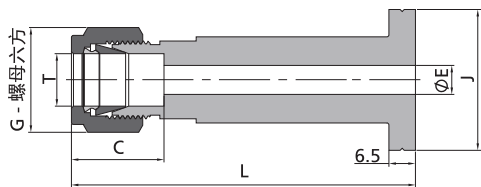

◆ 标准材料为 316 或蒙乃尔。
 法兰端用于 NPS 1/2 松套管法兰。
 法兰端尺寸满足“ASME B16.5 Class 2500”规范。
 法兰密封 A 表示表面粗糙度为 Ra 6.3-12.5 μm。
 法兰密封 B 表示表面粗糙度为 Ra 3.2-6.3 μm。

英制 Tube管							
T-Tube 管外径 (in.)	法兰 密封	基本 订购号	尺寸 in. (mm)				
			L	G	C	E	J
1/8	A	-LEC-FJ2A	3.18(80.8)	0.56(14.3)	0.60(15.2)	0.19(4.8)	1.36(34.5)
1/4	B	-LEC-FJ4A	3.18(80.8)	0.56(14.3)	0.60(15.2)	0.19(4.8)	1.36(34.5)
3/8	A	-LEC-FJ6A	3.24(82.3)	0.69(17.5)	0.66(16.8)	0.28(7.1)	1.36(34.5)
1/2	B	-LEC-FJ8A	3.24(82.3)	0.69(17.5)	0.66(16.8)	0.28(7.1)	1.36(34.5)
3/4	A	-LEC-FJ12A	3.35(85.1)	0.87(22.2)	0.90(22.9)	0.31(7.9)	1.36(34.5)
1	B	-LEC-FJ16A	3.35(85.1)	0.87(22.2)	0.90(22.9)	0.31(7.9)	1.36(34.5)

公制 Tube管							
T-Tube 管外径 (mm)	法兰 密封	基本 订购号	尺寸 in. (mm)				
			L	G	C	E	J
10	A	-LFC-MJ10A	82.6(3.25)	19.0(0.75)	17.2(0.68)	7.9(0.31)	34.5(1.36)
10	B	-LFC-MJ10B	82.6(3.25)	19.0(0.75)	17.2(0.68)	7.9(0.31)	34.5(1.36)

▶ 卡套螺母

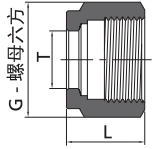

英制 Tube管			
T-Tube 管外径 (in.)	基本 订购号	尺寸 in. (mm)	
		L	G
1/16	-N-FJ1	0.31(7.9)	0.31(7.9)
1/8	-N-FJ2	0.47(11.9)	0.44(11.1)
3/16	-N-FJ3	0.47(11.9)	0.50(12.7)
1/4	-N-FJ4	0.50(12.7)	0.56(14.3)
5/16	-N-FJ5	0.53(13.5)	0.63(15.9)
3/8	-N-FJ6	0.56(14.2)	0.69(17.5)
1/2	-N-FJ8	0.69(17.5)	0.87(22.2)
5/8	-N-FJ10	0.69(17.5)	1.00(25.4)
3/4	-N-FJ12	0.69(17.5)	1.13(28.6)
7/8	-N-FJ14	0.69(17.5)	1.25(31.8)
1	-N-FJ16	0.81(20.6)	1.50(38.1)
1 1/8	-N-FJ18	1.21(30.8)	1.75(44.5)
1 1/4	-N-FJ20	1.25(31.8)	1.87(47.6)
1 1/2	-N-FJ24	1.50(38.1)	2.25(57.2)

公制 Tube管			
T-Tube 管外径 (mm)	基本 订购号	尺寸 mm(in.)	
		L	G
2	-N-MJ2	11.9(0.47)	12.0(0.47)
3	-N-MJ3	11.9(0.47)	12.0(0.47)
4	-N-MJ4	11.9(0.47)	12.0(0.47)
6	-N-MJ6	12.7(0.50)	14.0(0.55)
8	-N-MJ8	13.5(0.53)	16.0(0.63)
10	-N-MJ10	15.1(0.59)	19.0(0.75)
12	-N-MJ12	17.4(0.69)	22.0(0.87)
14	-N-MJ14	17.4(0.69)	25.0(0.98)
15	-N-MJ15	17.4(0.69)	25.0(0.98)
16	-N-MJ16	17.4(0.69)	25.0(0.98)
18	-N-MJ18	17.4(0.69)	30.0(1.18)
20	-N-MJ20	17.4(0.69)	32.0(1.26)
22	-N-MJ22	17.4(0.69)	32.0(1.26)
25	-N-MJ25	20.6(0.81)	38.0(1.50)
28	-N-MJ28	30.6(1.20)	46.0(1.81)
30	-N-MJ30	32.7(1.29)	50.0(1.97)
32	-N-MJ32	34.4(1.35)	50.0(1.97)
38	-N-MJ38	40.6(1.60)	60.0(2.36)

▶ 卡套滚花螺母

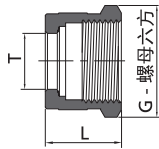

- ◆ 订购滚花螺母, 在卡套螺母订购号内加 K。
例: B-KN-FJ4

▶ 卡套阳螺纹螺母

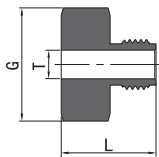

英制 Tube管			
T-Tube 管外径 (in.)	基本 订购号	尺寸 in. (mm)	
		L	G
1/16	-MN-FJ1	0.38(9.7)	0.25(6.4)
1/8	-MN-FJ2	0.53(13.5)	0.37(9.5)
1/4	-MN-FJ4	0.62(15.7)	0.50(12.7)
1/2	-MN-FJ8	0.87(22.1)	0.94(23.8)

公制 Tube管			
T-Tube 管外径 (mm)	基本 订购号	尺寸 mm(in.)	
		L	G
3	-MN-MJ3	13.5(0.53)	10.0(0.39)
6	-MN-MJ6	15.7(0.62)	14.0(0.55)
10	-MN-MJ10	22.1(0.87)	22.0(0.87)
12	-MN-MJ12	22.1(0.87)	24.0(0.94)

适用于内螺纹卡套接头, 如色谱分析接头。

组装示意图

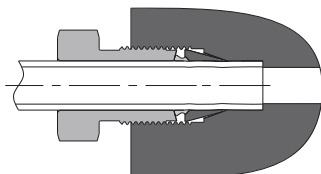

- ◆ 安装方法
01. 见第7页“安装说明”-“手动安装”。
 02. 不适用于使用手动预装器及液压预装器安装。
 03. 不适用于使用间隙检测规检测。

▶ 前卡套

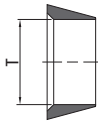

英制 Tube 管	
T-Tube 管外径 (in.)	基本订购号
1/16	-FF-FJ1
1/8	-FF-FJ2
3/16	-FF-FJ3
1/4	-FF-FJ4
5/16	-FF-FJ5
3/8	-FF-FJ6
1/2	-FF-FJ8
5/8	-FF-FJ10
3/4	-FF-FJ12
7/8	-FF-FJ14
1	-FF-FJ16
1 1/8	-FF-FJ18
1 1/4	-FF-FJ20
1 1/2	-FF-FJ24

公制 Tube 管	
T-Tube 管外径 (mm)	基本订购号
2	-FF-MJ2
3	-FF-MJ3
4	-FF-MJ4
6	-FF-MJ6
8	-FF-MJ8
10	-FF-MJ10
12	-FF-MJ12
14	-FF-MJ14
15	-FF-MJ15
16	-FF-MJ16
18	-FF-MJ18
20	-FF-MJ20
22	-FF-MJ22
25	-FF-MJ25
28	-FF-MJ28
30	-FF-MJ30
32	-FF-MJ32
38	-FF-MJ38

▶ 后卡套

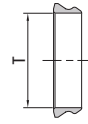

英制 Tube 管	
T-Tube 管外径 (in.)	基本订购号
1/16	-RF-FJ1
1/8	-RF-FJ2
3/16	-RF-FJ3
1/4	-RF-FJ4
5/16	-RF-FJ5
3/8	-RF-FJ6
1/2	-RF-FJ8
5/8	-RF-FJ10
3/4	-RF-FJ12
7/8	-RF-FJ14
1	-RF-FJ16
1 1/8	-RF-FJ18
1 1/4	-RF-FJ20
1 1/2	-RF-FJ24

公制 Tube 管	
T-Tube 管外径 (mm)	基本订购号
2	-RF-MJ2
3	-RF-MJ3
4	-RF-MJ4
6	-RF-MJ6
8	-RF-MJ8
10	-RF-MJ10
12	-RF-MJ12
14	-RF-MJ14
15	-RF-MJ15
16	-RF-MJ16
18	-RF-MJ18
20	-RF-MJ20
22	-RF-MJ22
25	-RF-MJ25
28	-RF-MJ28
30	-RF-MJ30
32	-RF-MJ32
38	-RF-MJ38

- ◆ 注: 1. 超过 1 in. 或 25 mm 的不锈钢前卡套表面镀银。
- 2. 除常用的金属材料卡套外, 还可提供 PTFE 和尼龙材质卡套, 具体请联系 E-JOE 依乔流体。

▶ 螺母 - 卡套组件

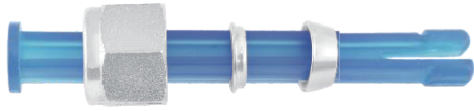

1 个螺母-卡套组件包含 1 个螺母、1 个后卡套和 1 个前卡套。

英制 Tube 管	
T-Tube 管外径 (in.)	基本 订购号
1/16	-NFS-FJ1
1/8	-NFS-FJ2
3/16	-NFS-FJ3
1/4	-NFS-FJ4
5/16	-NFS-FJ5
3/8	-NFS-FJ6
1/2	-NFS-FJ8
5/8	-NFS-FJ10
3/4	-NFS-FJ12

公制 Tube 管	
T-Tube 管外径 (mm)	基本 订购号
2	-NFS-MJ2
3	-NFS-MJ3
4	-NFS-MJ4
6	-NFS-MJ6
8	-NFS-MJ8
10	-NFS-MJ10
12	-NFS-MJ12
14	-NFS-MJ14
15	-NFS-MJ15
16	-NFS-MJ16
18	-NFS-MJ18

- ◆ 请按 5 的倍数订购螺母-卡套组件。
下图所示的产品带有心轴, 1 个心轴可以容纳 5 个螺母-卡套组件。



▶ 卡套组件



卡套组件包含 1 个后卡套和 1 个前卡套。

英制 Tube 管	
T-Tube 管外径 (in.)	基本 订购号
1/16	-FRS-FJ1
1/8	-FRS-FJ2
3/16	-FRS-FJ3
1/4	-FRS-FJ4
5/16	-FRS-FJ5
3/8	-FRS-FJ6
1/2	-FRS-FJ8
5/8	-FRS-FJ10
3/4	-FRS-FJ12

公制 Tube 管	
T-Tube 管外径 (mm)	基本 订购号
2	-FRS-MJ2
3	-FRS-MJ3
4	-FRS-MJ4
6	-FRS-MJ6
8	-FRS-MJ8
10	-FRS-MJ10
12	-FRS-MJ12
14	-FRS-MJ14
15	-FRS-MJ15
16	-FRS-MJ16
18	-FRS-MJ18

- ◆ 请按 10 的倍数订购螺母-卡套组件。
下图所示的产品带有心轴, 1 个心轴可以容纳 10 个螺母-卡套组件。



▶ 卡套-卡套管

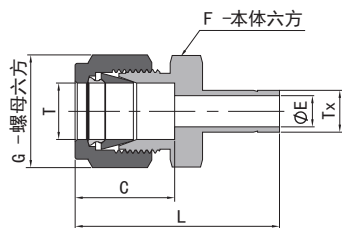

1"及以下

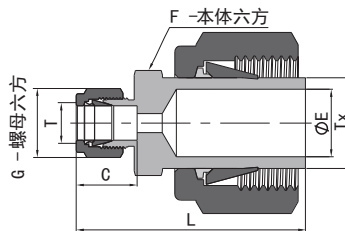

1 1/4"及以上

英制 Tube 管							
T- Tube 管外径 (in.)	T x- Tube 管外径 (in.)	基本 订购号	尺寸, in. (mm)				
			L	C	G	F	E
1/16	1/8	-S-FJ1FT2	1.15(29.2)	0.34(8.6)	0.31(7.9)	0.31(7.9)	0.05(1.3)
1/16	3/16	-S-FJ1FT3	1.18(30.0)	0.34(8.6)	0.31(7.9)	0.31(7.9)	0.05(1.3)
1/16	1/4	-S-FJ1FT4	1.24(31.5)	0.34(8.6)	0.31(7.9)	0.31(7.9)	0.05(1.3)
1/8	1/16	-S-FJ2FT1	1.14(29.0)	0.50(12.7)	0.44(11.1)	0.44(11.1)	0.03(0.8)
1/8	1/8	-S-FJ2FT2	1.32(33.5)	0.50(12.7)	0.44(11.1)	0.44(11.1)	0.08(2.0)
1/8	3/16	-S-FJ2FT3	1.35(34.3)	0.50(12.7)	0.44(11.1)	0.44(11.1)	0.09(2.3)
1/8	1/4	-S-FJ2FT4	1.42(36.1)	0.50(12.7)	0.44(11.1)	0.44(11.1)	0.09(2.3)
1/8	3/8	-S-FJ2FT6	1.48(37.6)	0.50(12.7)	0.44(11.1)	0.44(11.1)	0.09(2.3)
1/8	1/2	-S-FJ2FT8	1.74(44.2)	0.50(12.7)	0.44(11.1)	0.56(14.3)	0.09(2.3)
3/16	1/8	-S-FJ3FT2	1.37(34.8)	0.54(13.7)	0.50(12.7)	0.44(11.1)	0.08(2.0)
3/16	1/4	-S-FJ3FT4	1.46(37.1)	0.54(13.7)	0.50(12.7)	0.44(11.1)	0.12(3.0)
1/4	1/8	-S-FJ4FT2	1.45(36.8)	0.60(15.2)	0.56(14.3)	0.50(12.7)	0.08(2.0)
1/4	3/16	-S-FJ4FT3	1.48(37.6)	0.60(15.2)	0.56(14.3)	0.50(12.7)	0.12(3.0)
1/4	1/4	-S-FJ4FT4	1.54(39.1)	0.60(15.2)	0.56(14.3)	0.50(12.7)	0.17(4.3)
1/4	5/16	-S-FJ4FT5	1.57(39.9)	0.60(15.2)	0.56(14.3)	0.50(12.7)	0.19(4.8)
1/4	3/8	-S-FJ4FT6	1.60(40.6)	0.60(15.2)	0.56(14.3)	0.50(12.7)	0.19(4.8)
1/4	1/2	-S-FJ4FT8	1.82(46.2)	0.60(15.2)	0.56(14.3)	0.56(14.3)	0.19(4.8)
1/4	5/8	-S-FJ4FT10	1.89(48.0)	0.60(15.2)	0.56(14.3)	0.69(17.5)	0.19(4.8)
1/4	3/4	-S-FJ4FT12	1.88(47.8)	0.60(15.2)	0.56(14.3)	0.81(20.6)	0.19(4.8)
5/16	3/8	-S-FJ5FT6	1.65(41.9)	0.64(16.3)	0.63(15.9)	0.56(14.3)	0.25(6.4)
5/16	1/2	-S-FJ5FT8	1.87(47.5)	0.64(16.3)	0.63(15.9)	0.56(14.3)	0.25(6.4)
3/8	1/4	-S-FJ6FT4	1.63(41.4)	0.66(16.8)	0.69(17.5)	0.63(15.9)	0.17(4.3)
3/8	3/8	-S-FJ6FT6	1.70(43.2)	0.66(16.8)	0.69(17.5)	0.63(15.9)	0.27(6.9)
3/8	1/2	-S-FJ6FT8	1.91(48.5)	0.66(16.8)	0.69(17.5)	0.63(15.9)	0.28(7.1)
3/8	5/8	-S-FJ6FT10	1.98(50.3)	0.66(16.8)	0.69(17.5)	0.69(17.5)	0.28(7.1)
3/8	3/4	-S-FJ6FT12	1.98(50.3)	0.66(16.8)	0.69(17.5)	0.81(20.6)	0.28(7.1)
1/2	1/4	-S-FJ8FT4	1.77(45.0)	0.90(22.9)	0.87(22.2)	0.81(20.6)	0.17(4.3)
1/2	3/8	-S-FJ8FT6	1.84(46.7)	0.90(22.9)	0.87(22.2)	0.81(20.6)	0.27(6.9)
1/2	1/2	-S-FJ8FT8	2.06(52.3)	0.90(22.9)	0.87(22.2)	0.81(20.6)	0.37(9.4)
1/2	5/8	-S-FJ8FT10	2.12(53.8)	0.90(22.9)	0.87(22.2)	0.81(20.6)	0.41(10.4)
1/2	3/4	-S-FJ8FT12	2.12(53.8)	0.90(22.9)	0.87(22.2)	0.81(20.6)	0.41(10.4)
1/2	1	-S-FJ8FT16	2.37(60.2)	0.90(22.9)	0.87(22.2)	1.06(27.0)	0.41(10.4)
5/8	3/4	-S-FJ10FT12	2.15(54.6)	0.96(24.4)	1.00(25.4)	0.94(23.8)	0.50(12.7)
5/8	7/8	-S-FJ10FT14	2.21(56.1)	0.96(24.4)	1.00(25.4)	0.94(23.8)	0.50(12.7)
5/8	1	-S-FJ10FT16	2.40(61.0)	0.96(24.4)	1.00(25.4)	1.06(27.0)	0.50(12.7)
3/4	3/4	-S-FJ12FT12	2.15(54.6)	0.96(24.4)	1.13(28.6)	1.06(27.0)	0.58(14.7)
3/4	1	-S-FJ12FT16	2.46(62.5)	0.96(24.4)	1.13(28.6)	1.06(27.0)	0.62(15.7)
1	1 1/4	-S-FJ16AFT20	3.17(80.5)	1.23(31.2)	1.50(38.1)	1.37(34.9)	0.88(22.4)
1	1 1/2	-S-FJ16AFT24	3.51(89.2)	1.23(31.2)	1.50(38.1)	1.63(41.3)	0.88(22.4)
1	2	-S-FJ16AFT32	4.43(112.5)	1.23(31.2)	1.50(38.1)	2.13(54.0)	0.88(22.4)
1 1/4	1 1/2	-S-FJ20AFT24	4.10(104.1)	1.62(41.1)	1.87(47.6)	1.87(47.6)	1.09(27.7)

▶ 卡套-卡套管

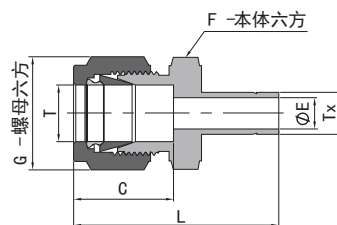

25mm 及以下

公制 Tube 管							
T-Tube 管外径 (mm)	Tx-Tube 管外径 (mm)	基本 订购号	尺寸, mm (in.)				
			L	C	G	F	E
2	3	-S-MJ2MT3	33.5(1.32)	12.9(0.51)	12.0(0.47)	12.0(0.47)	1.7(0.07)
3	4	-S-MJ3MT4	35.0(1.38)	12.9(0.51)	12.0(0.47)	12.0(0.47)	2.4(0.09)
3	6	-S-MJ3MT6	36.1(1.42)	12.9(0.51)	12.0(0.47)	12.0(0.47)	2.4(0.09)
3	10	-S-MJ3MT10	38.4(1.51)	12.9(0.51)	12.0(0.47)	14.0(0.55)	2.4(0.09)
4	6	-S-MJ4MT6	37.1(1.46)	13.7(0.54)	12.0(0.47)	12.0(0.47)	2.4(0.09)
6	3	-S-MJ6MT3	36.9(1.45)	15.3(0.60)	14.0(0.55)	14.0(0.55)	1.9(0.07)
6	8	-S-MJ6MT8	39.9(1.57)	15.3(0.60)	14.0(0.55)	14.0(0.55)	4.8(0.19)
6	10	-S-MJ6MT10	40.7(1.60)	15.3(0.60)	14.0(0.55)	14.0(0.55)	4.8(0.19)
6	12	-S-MJ6MT12	46.3(1.82)	15.3(0.60)	14.0(0.55)	14.0(0.55)	4.8(0.19)
6	18	-S-MJ6MT18	49.6(1.95)	15.3(0.60)	14.0(0.55)	22.0(0.87)	4.8(0.19)
8	6	-S-MJ8MT6	40.3(1.59)	16.2(0.64)	16.0(0.63)	15.0(0.59)	4.1(0.16)
8	10	-S-MJ8MT10	42.0(1.65)	16.2(0.64)	16.0(0.63)	15.0(0.59)	6.4(0.25)
8	12	-S-MJ8MT12	47.6(1.87)	16.2(0.64)	16.0(0.63)	15.0(0.59)	6.4(0.25)
10	6	-S-MJ10MT6	42.4(1.67)	17.2(0.68)	19.0(0.75)	18.0(0.71)	4.1(0.16)
10	8	-S-MJ10MT8	43.4(1.71)	17.2(0.68)	19.0(0.75)	18.0(0.71)	5.6(0.22)
10	12	-S-MJ10MT12	49.8(1.96)	17.2(0.68)	19.0(0.75)	18.0(0.71)	7.9(0.31)
10	15	-S-MJ10MT15	51.3(2.02)	17.2(0.68)	19.0(0.75)	18.0(0.71)	7.9(0.31)
10	18	-S-MJ10MT18	51.3(2.02)	17.2(0.68)	19.0(0.75)	22.0(0.87)	7.9(0.31)
12	6	-S-MJ12MT6	44.9(1.77)	22.8(0.90)	22.0(0.87)	22.0(0.87)	4.1(0.16)
12	8	-S-MJ12MT8	45.9(1.81)	22.8(0.90)	22.0(0.87)	22.0(0.87)	5.6(0.22)
12	10	-S-MJ12MT10	46.7(1.84)	22.8(0.90)	22.0(0.87)	22.0(0.87)	7.1(0.28)
12	16	-S-MJ12MT16	53.8(2.12)	22.8(0.90)	22.0(0.87)	22.0(0.87)	9.5(0.37)
12	18	-S-MJ12MT18	53.8(2.12)	22.8(0.90)	22.0(0.87)	22.0(0.87)	9.5(0.37)
12	20	-S-MJ12MT20	56.1(2.21)	22.8(0.90)	22.0(0.87)	22.0(0.87)	9.5(0.37)
12	22	-S-MJ12MT22	56.1(2.21)	22.8(0.90)	22.0(0.87)	24.0(0.94)	9.5(0.37)
12	25	-S-MJ12MT25	62.4(2.46)	22.8(0.90)	22.0(0.87)	27.0(1.06)	9.5(0.37)
16	12	-S-MJ16MT12	53.0(2.09)	24.4(0.96)	25.0(0.98)	24.0(0.94)	8.8(0.35)
18	12	-S-MJ18MT12	54.6(2.15)	24.4(0.96)	30.0(1.18)	27.0(1.06)	8.8(0.35)
18	16	-S-MJ18MT16	56.1(2.21)	24.4(0.96)	30.0(1.18)	27.0(1.06)	12.0(0.47)
18	20	-S-MJ18MT20	57.6(2.27)	24.4(0.96)	30.0(1.18)	27.0(1.06)	15.1(0.59)
18	22	-S-MJ18MT22	57.6(2.27)	24.4(0.96)	30.0(1.18)	27.0(1.06)	15.1(0.59)
18	25	-S-MJ18MT25	62.4(2.46)	24.4(0.96)	30.0(1.18)	27.0(1.06)	15.1(0.59)
20	16	-S-MJ20MT16	57.9(2.28)	26.0(1.02)	32.0(1.26)	30.0(1.18)	12.0(0.47)
20	18	-S-MJ20MT18	57.9(2.28)	26.0(1.02)	32.0(1.26)	30.0(1.18)	13.9(0.55)
20	22	-S-MJ20MT22	59.4(2.34)	26.0(1.02)	32.0(1.26)	30.0(1.18)	15.9(0.63)
20	25	-S-MJ20MT25	64.2(2.53)	26.0(1.02)	32.0(1.26)	30.0(1.18)	15.8(0.62)
22	18	-S-MJ22MT18	57.9(2.28)	26.0(1.02)	32.0(1.26)	30.0(1.18)	13.9(0.55)
22	20	-S-MJ22MT20	59.4(2.34)	26.0(1.02)	32.0(1.26)	30.0(1.18)	15.5(0.61)
22	25	-S-MJ22MT25	64.2(2.53)	26.0(1.02)	32.0(1.26)	30.0(1.18)	18.3(0.72)
25	18	-S-MJ25MT18	63.1(2.48)	31.3(1.23)	38.0(1.50)	35.0(1.38)	13.9(0.55)
25	20	-S-MJ25MT20	64.6(2.54)	31.3(1.23)	38.0(1.50)	35.0(1.38)	15.5(0.61)

▶ 卡套-卡套管

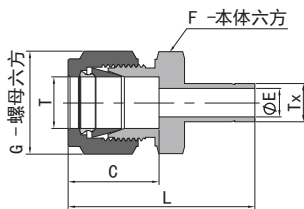

公制 Tube 管			英制 Tube 管				
T-Tube 管外径 (mm)	Tx-Tube 管外径 (in.)	基本 订购号	尺寸, mm (in.)				
			L	C	G	F	E
2	1/8	-S-MJ2FT2	33.5(1.32)	12.9(0.51)	12.0(0.47)	12.0(0.47)	1.7(0.07)
3	1/8	-S-MJ3FT2	33.5(1.32)	12.9(0.51)	12.0(0.47)	12.0(0.47)	2.0(0.08)
3	1/4	-S-MJ3FT4	36.1(1.42)	12.9(0.51)	12.0(0.47)	12.0(0.47)	2.4(0.09)
4	1/4	-S-MJ4FT4	37.1(1.46)	13.7(0.54)	12.0(0.47)	12.0(0.47)	2.4(0.09)
6	1/8	-S-MJ6FT2	36.9(1.45)	15.3(0.60)	14.0(0.55)	14.0(0.55)	2.0(0.08)
6	1/4	-S-MJ6FT4	39.2(1.54)	15.3(0.60)	14.0(0.55)	14.0(0.55)	4.4(0.17)
6	5/16	-S-MJ6FT5	39.9(1.57)	15.3(0.60)	14.0(0.55)	14.0(0.55)	4.8(0.19)
6	3/8	-S-MJ6FT6	40.7(1.60)	15.3(0.60)	14.0(0.55)	14.0(0.55)	4.8(0.19)
6	1/2	-S-MJ6FT8	46.3(1.82)	15.3(0.60)	14.0(0.55)	14.0(0.55)	4.8(0.19)
8	1/4	-S-MJ8FT4	40.3(1.59)	16.2(0.64)	16.0(0.63)	15.0(0.59)	4.4(0.17)
8	3/8	-S-MJ8FT6	42.0(1.65)	16.2(0.64)	16.0(0.63)	15.0(0.59)	6.4(0.25)
8	1/2	-S-MJ8FT8	47.6(1.87)	16.2(0.64)	16.0(0.63)	15.0(0.59)	6.4(0.25)
10	3/8	-S-MJ10FT6	44.4(1.75)	17.2(0.68)	19.0(0.75)	18.0(0.71)	6.8(0.27)
10	1/2	-S-MJ10FT8	49.8(1.96)	17.2(0.68)	19.0(0.75)	18.0(0.71)	7.9(0.31)
12	1/2	-S-MJ12FT8	52.3(2.06)	22.8(0.90)	22.0(0.87)	22.0(0.87)	9.3(0.37)
12	3/4	-S-MJ12FT12	53.8(2.12)	22.8(0.90)	22.0(0.87)	22.0(0.87)	9.5(0.37)
18	3/4	-S-MJ18FT12	56.1(2.21)	24.4(0.96)	30.0(1.18)	27.0(1.06)	14.7(0.58)
18	1	-S-MJ18FT16	62.4(2.46)	24.4(0.96)	30.0(1.18)	27.0(1.06)	15.1(0.59)
25	1	-S-MJ25FT16	69.5(2.74)	31.3(1.23)	38.0(1.50)	35.0(1.38)	20.2(0.80)

英制 Tube 管			公制 Tube 管				
T-Tube 管外径 (in.)	Tx-Tube 管外径 (mm)	基本 订购号	尺寸, in. (mm)				
			L	C	G	F	E
1/8	6	-S-FJ2MT6	1.42(36.1)	0.50(12.7)	0.44(11.1)	0.44(11.1)	0.09(2.3)

▶ 卡套穿板-卡套管

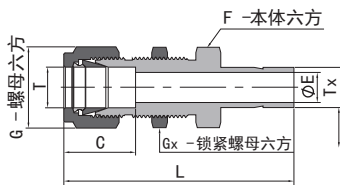

英制 Tube 管			尺寸, in. (mm)					
T-Tube 管外径 (in.)	Tx-Tube 管外径 (in.)	基本 订购号	L	C	G	F	Gx	E
1/4	1/4	-S-BFJ4FT4	2.20(55.9)	0.60(15.2)	0.56(14.3)	0.63(15.9)	0.63(15.9)	0.17(4.3)
3/8	3/8	-S-BFJ6FT6	2.41(61.2)	0.66(16.8)	0.69(17.5)	0.75(19.1)	0.75(19.1)	0.27(6.9)
1/2	1/2	-S-BFJ8FT8	2.87(72.9)	0.90(22.9)	0.87(22.2)	0.94(23.8)	0.94(23.8)	0.37(9.4)
5/8	5/8	-S-BFJ10FT10	2.96(75.2)	0.96(24.4)	1.00(25.4)	1.06(27.0)	1.06(27.0)	0.47(11.9)
3/4	3/4	-S-BFJ12FT12	3.21(81.5)	0.96(24.4)	1.13(28.6)	1.19(30.2)	1.19(30.2)	0.58(14.7)
1	1	-S-BFJ16FT16	3.95(100.3)	1.23(31.2)	1.50(38.1)	1.63(41.3)	1.63(41.3)	0.80(20.3)

▶ 卡套-卡套管弯头

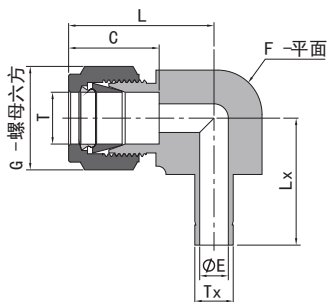

公制 Tube 管			尺寸, mm (in.)					
T-Tube 管外径 (mm)	Tx-Tube 管外径 (mm)	基本 订购号	L	C	G	F	E	Lx
12	12	-L-MJ12MT12	38.1(1.50)	22.8(0.90)	22.0(0.87)	23.8(0.94)	8.8(0.35)	39.2(1.54)

▶ 主管支管卡套管三通

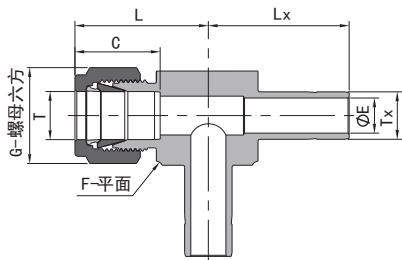

英制 Tube 管								
T-Tube 管外径 (in.)	Tx-Tube 管外径 (in.)	基本 订购号	尺寸, in. (mm)					
			L	C	G	F	E	Lx
1/4	1/4	-T-FJ4FT4FT4	1.06 (26.9)	0.60 (15.2)	0.56 (14.3)	0.50 (12.7)	0.17 (4.3)	0.98 (25.0)
3/8	1/4	-T-FJ6FT4FT4	1.20 (30.5)	0.66 (16.8)	0.69 (17.5)	0.63 (15.9)	0.17 (4.3)	1.05 (26.6)
3/8	3/8	-T-FJ6FT6FT6	1.20 (30.5)	0.66 (16.8)	0.69 (17.5)	0.63 (15.9)	0.27 (6.8)	1.10 (28.0)
1/2	3/8	-T-FJ8FT6FT6	1.42 (36.1)	0.90 (22.9)	0.87 (22.2)	0.81 (20.6)	0.27 (6.8)	1.24 (31.4)
1/2	1/2	-T-FJ8FT8FT8	1.42 (36.1)	0.90 (22.9)	0.87 (22.2)	0.81 (20.6)	0.37 (9.4)	1.50 (38.0)

▶ 支管卡套管三通

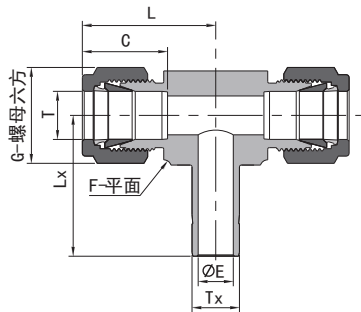

英制 Tube 管								
T-Tube 管外径 (in.)	Tx-Tube 管外径 (in.)	基本 订购号	尺寸, in. (mm)					
			L	C	G	F	E	Lx
1/4	1/4	-T-FJ4FJ4FT4	1.06 (26.9)	0.60 (15.2)	0.56 (14.3)	0.50 (12.7)	0.17 (4.3)	0.98 (25.0)
3/8	3/8	-T-FJ6FJ6FT6	1.20 (30.5)	0.66 (16.8)	0.69 (17.5)	0.63 (15.9)	0.27 (6.8)	1.10 (28.0)
1/2	1/2	-T-FJ8FJ8FT8	1.42 (36.1)	0.90 (22.9)	0.87 (22.2)	0.81 (20.6)	0.37 (9.4)	1.50 (38.0)

▶ 主管卡套管三通

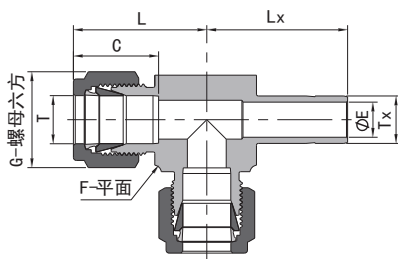

英制 Tube 管								
T-Tube 管外径 (in.)	Tx-Tube 管外径 (in.)	基本 订购号	尺寸, in. (mm)					
			L	C	G	F	E	Lx
1/4	1/4	-T-FJ4FT4FJ4	1.06 (26.9)	0.60 (15.2)	0.56 (14.3)	0.50 (12.7)	0.17 (4.3)	0.98 (25.0)
3/8	1/4	-T-FJ6FT4FJ6	1.20 (30.5)	0.66 (16.8)	0.69 (17.5)	0.63 (15.9)	0.17 (4.3)	1.05 (26.6)
3/8	3/8	-T-FJ6FT6FJ6	1.20 (30.5)	0.66 (16.8)	0.69 (17.5)	0.63 (15.9)	0.27 (6.8)	1.10 (28.0)
1/2	3/8	-T-FJ8FT6FJ8	1.42 (36.1)	0.90 (22.9)	0.87 (22.2)	0.81 (20.6)	0.27 (6.8)	1.24 (31.4)
1/2	1/2	-T-FJ8FT8FJ8	1.42 (36.1)	0.90 (22.9)	0.87 (22.2)	0.81 (20.6)	0.37 (9.4)	1.50 (38.0)

▶ 主管双卡套管三通

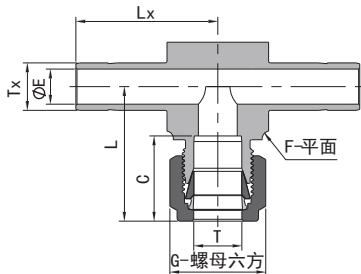

英制 Tube 管								
T-Tube 管外径 (in.)	Tx-Tube 管外径 (in.)	基本 订购号	尺寸, in. (mm)					
			L	C	G	F	E	Lx
1/4	1/4	-T-FT4FT4FJ4	1.06 (26.9)	0.60 (15.2)	0.56 (14.3)	0.50 (12.7)	0.17 (4.3)	0.98 (25.0)
3/8	3/8	-T-FT6FT6FJ6	1.20 (30.5)	0.66 (16.8)	0.69 (17.5)	0.63 (15.9)	0.27 (6.8)	1.10 (28.0)
1/2	1/2	-T-FT8FT8FJ8	1.42 (36.1)	0.90 (22.9)	0.87 (22.2)	0.81 (20.6)	0.37 (9.4)	1.50 (38.0)

▶ 软管插头

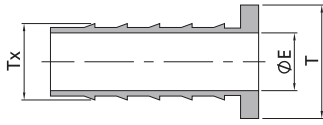

软管插头用于保护与卡套接头一起使用的软塑料管。
 如要确定软管插头的正确尺寸, 应先确认软塑料管的外径和内径。

英制 Tube 管			
T-Tube 管外径 (in.)	T-Tube 管内径 (in.)	基本订购号	E in. (mm)
3/16	1/8	-IN-F3AT2	0.09(2.3)
1/4	1/8	-IN-F4AT2	0.09(2.3)
1/4	0.17	-IN-F4AT017	0.11(2.8)
1/4	3/16	-IN-F4AT3	0.14(3.5)
5/16	1/8	-IN-F5AT2	0.09(2.3)
5/16	3/16	-IN-F5AT3	0.12(3.0)
5/16	1/4	-IN-F5AT4	0.19(4.8)
3/8	3/16	-IN-F6AT3	0.12(3.0)
3/8	1/4	-IN-F6AT4	0.19(4.8)
1/2	1/4	-IN-F8AT4	0.19(4.8)
1/2	3/8	-IN-F8AT6	0.31(7.9)
5/8	3/8	-IN-F10AT6	0.31(7.9)
5/8	1/2	-IN-F10AT8	0.44(11.1)
3/4	1/2	-IN-F12AT8	0.44(11.1)
3/4	5/8	-IN-F12AT10	0.56(14.2)
1	3/4	-IN-F16AT12	0.69(17.5)

公制 Tube 管			
T-Tube 管外径 (mm)	T-Tube 管内径 (mm)	基本订购号	E mm (in.)
6	4	-IN-M6NT4	2.8(0.11)
8	6	-IN-M8NT6	4.4(0.17)
10	8	-IN-M10NT8	6.4(0.25)
12	8	-IN-M12NT8	6.4(0.25)
12	10	-IN-M12NT10	8.3(0.33)

订购信息:
 在基本订购号前面加上材料代码组成完整的订购号。

材料	材料代码
316 不锈钢	SS
黄铜	B
合金 400	M

▶ 端口接头

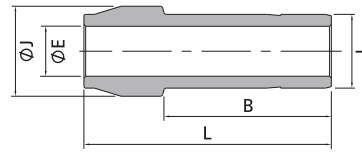

1" / 25 mm 及以下

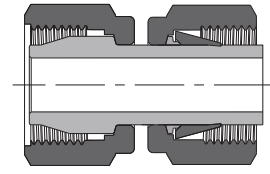

1 1/4" / 28 mm 及以上

英制 Tube 管					
T-Tube 管外径 (in.)	基本订购号	尺寸, in. (mm)			
		L	B	E	J
1/16	-P-FJ1	0.63(16.0)	0.44(11.1)	0.03(0.8)	0.13(3.4)
1/8	-P-FJ2	0.97(24.7)	0.65(16.6)	0.08(2.0)	0.24(6.0)
1/4	-P-FJ4	1.06(27.0)	0.75(19.0)	0.17(4.3)	0.36(9.1)
5/16	-P-FJ5	1.11(28.3)	0.80(20.2)	0.22(5.6)	0.43(10.8)
3/8	-P-FJ6	1.12(28.5)	0.81(20.6)	0.27(6.8)	0.48(12.3)
1/2	-P-FJ8	1.68(42.6)	1.13(28.7)	0.37(9.4)	0.61(15.5)
5/8	-P-FJ10	1.64(41.7)	1.16(29.4)	0.47(11.9)	0.74(18.7)
3/4	-P-FJ12	1.65(41.9)	1.13(28.6)	0.58(14.7)	0.87(22.0)
1	-P-FJ16	2.12(53.8)	1.43(36.4)	0.80(20.3)	1.11(28.3)
1 1/4	-P-FJ20	2.87(73.0)	2.07(52.6)	1.02(25.8)	1.54(39.0)
1 1/2	-P-FJ24	3.48(88.4)	2.50(63.6)	1.24(31.5)	1.85(47.0)

公制 Tube 管					
T-Tube 管外径 (mm)	基本订购号	尺寸, mm (in.)			
		L	B	E	J
3	-P-MJ3	24.6(0.97)	16.4(0.65)	1.9(0.07)	5.9(0.23)
6	-P-MJ6	27.0(1.06)	18.7(0.74)	4.1(0.16)	8.8(0.35)
8	-P-MJ8	28.7(1.13)	20.1(0.79)	5.6(0.22)	10.8(0.43)
10	-P-MJ10	30.2(1.19)	20.3(0.80)	7.1(0.28)	13.0(0.51)
12	-P-MJ12	37.5(1.48)	25.9(1.02)	8.8(0.35)	15.1(0.59)
15	-P-MJ15	40.4(1.59)	28.8(1.13)	11.2(0.44)	18.0(0.71)
16	-P-MJ16	40.4(1.59)	27.6(1.09)	12.0(0.47)	18.8(0.74)
18	-P-MJ18	40.9(1.61)	27.6(1.09)	13.9(0.55)	21.0(0.83)
20	-P-MJ20	42.6(1.68)	29.4(1.16)	15.5(0.61)	23.0(0.91)
25	-P-MJ25	54.6(2.15)	37.0(1.46)	19.9(0.78)	28.0(1.10)
28	-P-MJ28	66.0(2.60)	46.9(1.85)	22.5(0.89)	34.4(1.35)
30	-P-MJ30	68.6(2.70)	48.2(1.90)	24.3(0.96)	37.4(1.47)
32	-P-MJ32	74.2(2.92)	52.8(2.08)	26.5(1.04)	39.4(1.55)
38	-P-MJ38	87.0(3.43)	61.7(2.43)	31.6(1.24)	47.2(1.86)

▶ 变径端口接头

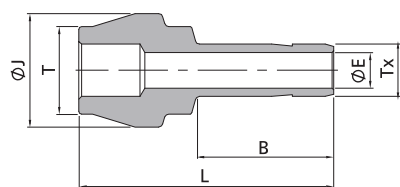

1" /25 mm 及以下

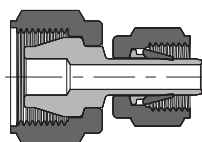

1 1/4" /28 mm 及以上

英制 Tube 管						
T-Tube 管外径 (in.)	T-Tube 管外径 (in.)	基本 订购号	尺寸, in. (mm)			
			L	B	E	J
1/8	1/16	-P-FJ2FJ1	0.84(21.3)	0.41(10.3)	0.03(0.8)	0.24(6.0)
1/4	1/16	-P-FJ4FJ1	0.81(20.7)	0.37(9.3)	0.03(0.8)	0.36(9.1)
1/4	1/8	-P-FJ4FJ2	1.00(25.4)	0.56(14.2)	0.08(2.0)	0.36(9.1)
3/8	1/8	-P-FJ6FJ2	1.01(25.7)	0.53(13.5)	0.08(2.0)	0.48(12.3)
3/8	1/4	-P-FJ6FJ4	1.11(28.2)	0.66(16.8)	0.17(4.3)	0.48(12.3)
1/2	1/4	-P-FJ8FJ4	1.34(34.1)	0.63(15.9)	0.17(4.3)	0.61(15.5)
1/2	3/8	-P-FJ8FJ6	1.40(35.6)	0.70(17.7)	0.27(6.8)	0.61(15.5)
3/4	1/2	-P-FJ12FJ8	1.65(42.0)	0.95(24.1)	0.37(9.4)	0.87(22.0)
1	1/2	-P-FJ16FJ8	1.69(42.9)	0.96(24.4)	0.37(9.4)	1.12(28.5)
1	3/4	-P-FJ16FJ12	1.72(43.7)	1.03(26.1)	0.58(14.7)	1.12(28.5)

公制 Tube 管						
T-Tube 管外径 (mm)	T-Tube 管外径 (mm)	基本 订购号	尺寸, mm (in.)			
			L	B	E	J
6	3	-P-MJ6MJ3	25.7(1.01)	13.8(0.54)	1.9(0.07)	8.8(0.35)
8	6	-P-MJ8MJ6	27.5(1.08)	15.7(0.62)	4.1(0.16)	10.8(0.43)
10	6	-P-MJ10MJ6	29.2(1.15)	15.8(0.62)	4.1(0.16)	13.0(0.51)
10	8	-P-MJ10MJ8	29.5(1.16)	16.3(0.64)	5.6(0.22)	13.0(0.51)
12	6	-P-MJ12MJ6	31.2(1.23)	16.1(0.63)	4.1(0.16)	15.1(0.59)
12	8	-P-MJ12MJ8	31.4(1.24)	16.6(0.65)	5.6(0.22)	15.1(0.59)
12	10	-P-MJ12MJ10	32.0(1.26)	17.4(0.69)	7.1(0.28)	15.1(0.59)
16	12	-P-MJ16MJ12	39.5(1.56)	23.2(0.91)	8.8(0.35)	18.8(0.74)
28	25	-P-MJ28MJ25	56.5(2.22)	33.0(1.30)	19.9(0.78)	34.3(1.35)
32	25	-P-MJ32MJ25	65.5(2.58)	33.0(1.30)	19.9(0.78)	39.4(1.55)
38	25	-P-MJ38MJ25	71.0(2.80)	33.3(1.31)	19.9(0.78)	47.2(1.86)

▶ 卫生法兰接头

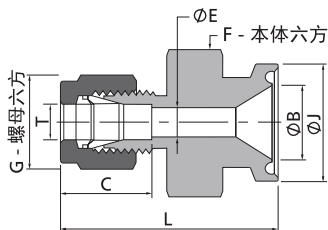

◆ 法兰端尺寸满足“ASME BPE”规范。

英制 Tube 管									
T-Tube 管外径 (in.)	法兰 尺寸 (in.)	基本 订购号	尺寸, in. (mm)						
			L	B	C	E	F	J	G
1/4	1/2	-S-FJ4SC8	1.57(39.9)	0.37(9.4)	0.60(15.2)	0.19(4.8)	1.00(25.4)	0.98(24.9)	0.56(14.3)
1/4	3/4	-S-FJ4SC12	1.57(39.9)	0.62(15.7)	0.60(15.2)	0.19(4.8)	1.00(25.4)	0.98(24.9)	0.56(14.3)
1/4	1	-S-FJ4SC16	1.57(39.9)	0.87(22.1)	0.60(15.2)	0.19(4.8)	1.37(34.9)	1.98(50.4)	0.56(14.3)
1/4	1 1/2	-S-FJ4SC24	1.57(39.9)	1.37(34.8)	0.60(15.2)	0.19(4.8)	1.37(34.9)	1.98(50.4)	0.56(14.3)
3/8	1/2	-S-FJ6SC8	1.63(41.4)	0.37(9.4)	0.66(16.8)	0.28(7.1)	1.00(25.4)	0.98(24.9)	0.69(17.5)
3/8	3/4	-S-FJ6SC12	1.63(41.4)	0.62(15.7)	0.66(16.8)	0.28(7.1)	1.00(25.4)	0.98(24.9)	0.69(17.5)
3/8	1	-S-FJ6SC16	1.63(41.4)	0.87(22.1)	0.66(16.8)	0.28(7.1)	1.37(34.9)	1.98(50.4)	0.69(17.5)
3/8	1 1/2	-S-FJ6SC24	1.63(41.4)	1.37(34.8)	0.66(16.8)	0.28(7.1)	1.37(34.9)	1.98(50.4)	0.69(17.5)
1/2	1/2	-S-FJ8SC8	1.74(44.2)	0.37(9.4)	0.90(22.9)	0.37(9.4)	1.00(25.4)	0.98(24.9)	0.87(22.2)
1/2	3/4	-S-FJ8SC12	1.74(44.2)	0.62(15.7)	0.90(22.9)	0.41(10.4)	1.00(25.4)	0.98(24.9)	0.87(22.2)
1/2	1	-S-FJ8SC16	1.74(44.2)	0.87(22.1)	0.90(22.9)	0.41(10.4)	1.37(34.9)	1.98(50.4)	0.87(22.2)
1/2	1 1/2	-S-FJ8SC24	1.74(44.2)	1.37(34.8)	0.90(22.9)	0.41(10.4)	1.37(34.9)	1.98(50.4)	0.87(22.2)
1	1	-S-FJ16SC16	1.91(48.5)	0.87(22.1)	1.23(31.2)	0.87(22.1)	1.37(34.9)	1.98(50.4)	1.50(38.1)
1	2	-S-FJ16SC32	2.49(63.2)	1.37(34.8)	1.23(31.2)	0.88(22.4)	2.75(69.9)	2.52(64.0)	1.50(38.1)

► 卡套管-阳螺纹

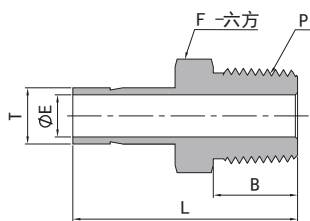

1" 及以下

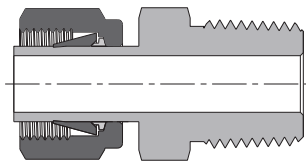

1 1/4" 及以上

英制 Tube 管			NPT 螺纹			
T-Tube 管外径 (in.)	P-NPT 尺寸	基本 订购号	尺寸, in. (mm)			
			L	B	E*	F
1/16	1/8	-S-FT1N2	1.00(25.4)	0.38(9.7)	0.03(0.8)	0.44(11.1)
1/8	1/8	-S-FT2N2	1.16(29.5)	0.38(9.7)	0.08(2.0)	0.44(11.1)
1/8	1/4	-S-FT2N4	1.37(34.8)	0.56(14.2)	0.08(2.0)	0.56(14.3)
3/16	1/8	-S-FT3N2	1.19(30.2)	0.38(9.7)	0.12(3.0)	0.44(11.1)
3/16	1/4	-S-FT3N4	1.40(35.6)	0.56(14.2)	0.12(3.0)	0.56(14.3)
1/4	1/8	-S-FT4N2	1.25(31.8)	0.38(9.7)	0.17(4.3)	0.44(11.1)
1/4	1/4	-S-FT4N4	1.46(37.1)	0.56(14.2)	0.17(4.3)	0.56(14.3)
1/4	3/8	-S-FT4N6	1.49(37.8)	0.56(14.2)	0.17(4.3)	0.69(17.5)
1/4	1/2	-S-FT4N8	1.71(43.4)	0.75(19.1)	0.17(4.3)	0.87(22.2)
5/16	1/8	-S-FT5N2	1.29(32.8)	0.38(9.7)	0.19(4.8)	0.44(11.1)
5/16	1/4	-S-FT5N4	1.50(38.1)	0.56(14.2)	0.22(5.6)	0.56(14.3)
5/16	3/8	-S-FT5N6	1.53(38.9)	0.56(14.2)	0.22(5.6)	0.69(17.5)
5/16	1/2	-S-FT5N8	1.74(44.2)	0.75(19.1)	0.22(5.6)	0.87(22.2)
3/8	1/8	-S-FT6N2	1.32(33.5)	0.38(9.7)	0.19(4.8)	0.44(11.1)
3/8	1/4	-S-FT6N4	1.53(38.9)	0.56(14.2)	0.27(6.9)	0.56(14.3)
3/8	3/8	-S-FT6N6	1.56(39.6)	0.56(14.2)	0.27(6.9)	0.69(17.5)
3/8	1/2	-S-FT6N8	1.78(45.2)	0.75(19.1)	0.27(6.9)	0.87(22.2)
1/2	1/4	-S-FT8N4	1.75(44.5)	0.56(14.2)	0.28(7.1)	0.56(14.3)
1/2	3/8	-S-FT8N6	1.78(45.2)	0.56(14.2)	0.37(9.4)	0.69(17.5)
1/2	1/2	-S-FT8N8	2.00(50.8)	0.75(19.1)	0.37(9.4)	0.87(22.2)
5/8	1/2	-S-FT10N8	2.06(52.3)	0.75(19.1)	0.47(11.9)	0.87(22.2)
3/4	1/2	-S-FT12N8	2.06(52.3)	0.75(19.1)	0.47(11.9)	0.87(22.2)
3/4	3/4	-S-FT12N12	2.06(52.3)	0.75(19.1)	0.58(14.7)	1.06(27.0)
3/4	1	-S-FT12N16	2.41(61.2)	0.94(23.9)	0.58(14.7)	1.37(34.9)
1	3/4	-S-FT16N12	2.31(58.7)	0.75(19.1)	0.62(15.7)	1.06(27.0)
1	1	-S-FT16N16	2.60(66.0)	0.94(23.9)	0.80(20.3)	1.37(34.9)
1 1/4	1 1/4	-S-AFT20N20	3.16(80.3)	0.94(23.9)	1.02(25.9)	1.75(44.5)
1 1/2	1 1/2	-S-AFT24N24	3.72(94.5)	1.03(26.2)	1.25(31.8)	2.13(54.0)

英制 Tube 管			ISO 锥螺纹 (RT)			
T-Tube 管外径 (in.)	P-RT 尺寸	基本 订购号	尺寸, in. (mm)			
			L	B	E*	F
1/8	1/8	-S-FT2RT2	1.16(29.5)	0.38(9.7)	0.08(2.0)	0.44(11.1)
1/8	1/4	-S-FT2RT4	1.37(34.8)	0.56(14.2)	0.08(2.0)	0.56(14.3)
1/4	1/8	-S-FT4RT2	1.25(31.8)	0.38(9.7)	0.17(4.3)	0.44(11.1)
1/4	1/4	-S-FT4RT4	1.46(37.1)	0.56(14.2)	0.17(4.3)	0.56(14.3)
1/4	3/8	-S-FT4RT6	1.49(37.8)	0.56(14.2)	0.17(4.3)	0.69(17.5)
1/4	1/2	-S-FT4RT8	1.71(43.4)	0.75(19.1)	0.17(4.3)	0.87(22.2)
5/16	1/8	-S-FT5RT2	1.29(32.8)	0.38(9.7)	0.19(4.8)	0.44(11.1)
5/16	1/4	-S-FT5RT4	1.50(38.1)	0.56(14.2)	0.22(5.6)	0.56(14.3)
3/8	1/4	-S-FT6RT4	1.53(38.9)	0.56(14.2)	0.27(6.9)	0.56(14.3)
3/8	3/8	-S-FT6RT6	1.56(39.6)	0.56(14.2)	0.27(6.9)	0.69(17.5)
3/8	1/2	-S-FT6RT8	1.78(45.2)	0.75(19.1)	0.27(6.9)	0.87(22.2)
1/2	1/4	-S-FT8RT4	1.75(44.5)	0.56(14.2)	0.28(7.1)	0.56(14.3)
1/2	3/8	-S-FT8RT6	1.78(45.2)	0.56(14.2)	0.37(9.4)	0.69(17.5)
1/2	1/2	-S-FT8RT8	2.00(50.8)	0.75(19.1)	0.37(9.4)	0.87(22.2)
5/8	3/8	-S-FT10RT6	1.91(48.5)	0.56(14.2)	0.37(9.5)	0.69(17.5)
5/8	1/2	-S-FT10RT8	2.06(52.3)	0.75(19.1)	0.47(11.9)	0.87(22.2)
3/4	3/4	-S-FT12RT12	2.06(52.3)	0.75(19.1)	0.58(14.7)	1.06(27.0)
1	1	-S-FT16RT16	2.60(66.0)	0.94(23.9)	0.80(20.3)	1.37(34.9)

◆ 尺寸"E"为最小公称孔口,此孔口在管螺纹端、直螺纹端可能会更大。

► 卡套管-阳螺纹

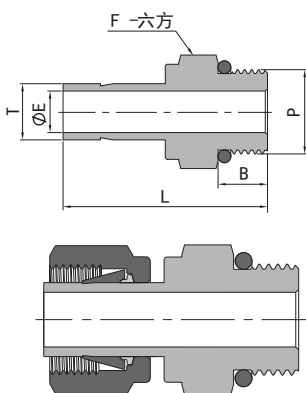
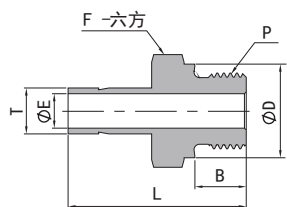
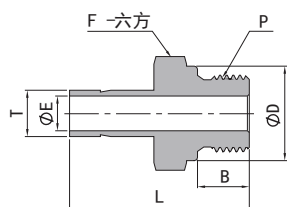

◆ 转接至 SAE J1926-1、ISO 11926-1 和 MS 16142 直螺纹凸台。

◆ 尺寸“E”为最小公称孔口,此孔口在管螺纹端、直螺纹端可能会更大。

英制 Tube 管			ISO 平行螺纹 (BS)				
T-Tube 管外径 (in.)	P-BS 尺寸	基本 订购号	尺寸, in. (mm)				
			L	B	E*	F	D
1/8	1/8	-S-FT2BS2	1.22(31.0)	0.28(7.1)	0.08(2.0)	0.56(14.3)	0.54(13.7)
1/8	1/4	-S-FT2BS4	1.41(35.8)	0.44(11.2)	0.08(2.0)	0.75(19.1)	0.70(17.8)
1/4	1/8	-S-FT4BS2	1.31(33.3)	0.28(7.1)	0.16(4.1)	0.56(14.3)	0.54(13.7)
1/4	1/4	-S-FT4BS4	1.50(38.1)	0.44(11.2)	0.17(4.3)	0.75(19.1)	0.70(17.8)
3/8	1/8	-S-FT6BS2	1.29(32.8)	0.28(7.1)	0.16(4.1)	0.56(14.3)	0.54(13.7)
3/8	1/4	-S-FT6BS4	1.57(39.9)	0.44(11.2)	0.23(5.8)	0.75(19.1)	0.70(17.8)
3/8	3/8	-S-FT6BS6	1.60(40.6)	0.44(11.2)	0.27(6.9)	0.87(22.2)	0.85(21.6)
3/8	1/2	-S-FT6BS8	1.69(42.9)	0.56(14.2)	0.28(7.1)	1.06(27.0)	1.02(25.9)
1/2	1/4	-S-FT8BS4	1.79(45.5)	0.44(11.2)	0.23(5.8)	0.75(19.1)	0.70(17.8)
1/2	3/8	-S-FT8BS6	1.82(46.2)	0.44(11.2)	0.31(7.9)	0.87(22.2)	0.85(21.6)
1/2	1/2	-S-FT8BS8	1.94(49.2)	0.56(14.2)	0.37(9.4)	1.06(27.0)	1.02(25.9)
5/8	1/2	-S-FT10BS8	1.97(50.0)	0.56(14.2)	0.47(11.9)	1.06(27.0)	1.02(25.9)
3/4	3/4	-S-FT12BS12	2.16(54.9)	0.63(16.0)	0.58(14.7)	1.31(33.3)	1.26(32.0)
1	1	-S-FT16BS16	2.54(64.5)	0.72(18.3)	0.80(20.3)	1.63(41.3)	1.53(38.9)

英制 Tube 管			ISO 平行螺纹 (BR)				
T-Tube 管外径 (in.)	P-RP 尺寸	基本 订购号	尺寸, in. (mm)				
			L	B	E*	F	D
1/8	1/8	-S-FT2BR2	1.09(27.7)	0.28(7.1)	0.08(2.0)	0.56(14.3)	0.54(13.7)
1/8	1/4	-S-FT2BR4	1.31(33.3)	0.44(11.2)	0.08(2.0)	0.75(19.1)	0.70(17.8)
1/4	1/8	-S-FT4BR2	1.19(30.2)	0.28(7.1)	0.16(4.1)	0.56(14.3)	0.54(13.7)
1/4	1/4	-S-FT4BR4	1.50(38.1)	0.44(11.2)	0.18(4.6)	0.75(19.1)	0.70(17.8)
3/8	1/8	-S-FT6BR2	1.34(34.0)	0.28(7.1)	0.16(4.1)	0.75(19.1)	0.54(13.7)
3/8	1/4	-S-FT6BR4	1.47(37.3)	0.44(11.2)	0.25(6.4)	0.75(19.1)	0.70(17.8)
3/8	3/8	-S-FT6BR6	1.50(38.1)	0.44(11.2)	0.27(6.9)	0.87(22.2)	0.85(21.6)
3/8	1/2	-S-FT6BR8	1.69(42.9)	0.56(14.2)	0.27(6.9)	1.06(27.0)	1.02(25.9)
1/2	1/4	-S-FT8BR4	1.69(42.9)	0.44(11.2)	0.25(6.4)	0.75(19.1)	0.70(17.8)
1/2	3/8	-S-FT8BR6	1.72(43.7)	0.44(11.2)	0.31(7.9)	0.87(22.2)	0.85(21.6)
1/2	1/2	-S-FT8BR8	1.94(49.3)	0.56(14.2)	0.37(9.4)	1.06(27.0)	1.02(25.9)
5/8	1/2	-S-FT10BR8	1.97(50.0)	0.56(14.2)	0.47(11.9)	1.06(27.0)	1.02(25.9)
3/4	3/4	-S-FT12BR12	2.09(53.1)	0.63(16.0)	0.58(14.7)	1.32(33.5)	1.26(32.0)
1	1	-S-FT16BR16	2.49(63.3)	0.72(18.3)	0.78(19.8)	1.63(41.3)	1.53(38.9)

英制 Tube 管			SAE/MS 直螺纹 (ST)				
T-Tube 管外径 (in.)	P-SAE 名义 尺寸	P-SAE/MS 螺纹规格	基本 订购号	尺寸, in. (mm)			
				L	B	E*	F
1/8	2	5/16-24	-S-FT2ST5	1.20(30.5)	0.30(7.6)	0.08(2.0)	0.44(11.1)
1/4	4	7/16-20	-S-FT4ST7	1.39(35.3)	0.36(9.1)	0.17(4.3)	0.56(14.3)
3/8	4	7/16-20	-S-FT6ST7	1.46(37.1)	0.36(9.1)	0.20(5.1)	0.56(14.3)
3/8	6	9/16-18	-S-FT6ST9	1.52(38.6)	0.39(9.9)	0.27(6.9)	0.69(17.5)
3/8	8	3/4-16	-S-FT6ST12	1.60(40.6)	0.44(11.2)	0.27(6.9)	0.87(22.2)
1/2	6	9/16-18	-S-FT8ST9	1.74(44.2)	0.39(9.9)	0.28(7.1)	0.69(17.5)
1/2	8	3/4-16	-S-FT8ST12	1.82(46.2)	0.44(11.2)	0.37(9.4)	0.87(22.2)
5/8	10	7/8-14	-S-FT10ST14	1.94(49.3)	0.50(12.7)	0.47(11.9)	1.00(25.4)
3/4	12	1 1/16-12	-S-FT12ST17	2.10(53.3)	0.59(15.0)	0.58(14.7)	1.25(31.8)
1	16	1 5/16-12	-S-FT16ST21	2.41(61.2)	0.59(15.0)	0.80(20.3)	1.50(38.1)
1 1/4	20	1 5/8-12	-S-AFT20ST26	2.81(71.4)	0.59(15.0)	1.02(25.9)	1.87(47.6)
1 1/2	24	1 7/8-12	-S-AFT24ST30	3.28(83.3)	0.59(15.0)	1.25(31.8)	2.13(54.0)

► 卡套管-阳螺纹

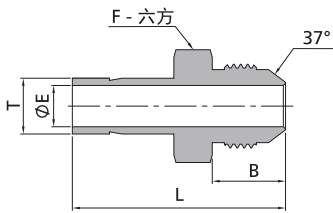

英制 Tube 管				37 扩口 (AN)			
T-Tube 管外径 (in.)	AN Tube 管扩口尺寸	基本 订购号	尺寸, in. (mm)				
			L	B	E*	F	
1/4	1/4	-S-FT4AN4	1.46(37.1)	0.55(14.0)	0.17(4.3)	0.50(12.7)	
3/8	1/4	-S-FT6AN4	1.53(38.9)	0.55(14.0)	0.17(4.3)	0.50(12.7)	
3/8	3/8	-S-FT6AN6	1.56(39.6)	0.56(14.2)	0.27(6.9)	0.63(15.9)	
1/2	1/2	-S-FT8AN8	1.91(48.5)	0.66(16.8)	0.37(9.4)	0.81(20.6)	
3/4	3/4	-S-FT12AN12	2.21(56.1)	0.86(21.8)	0.58(14.7)	1.13(28.6)	
1	1	-S-FT16AN16	2.58(65.5)	0.91(23.1)	0.80(20.3)	1.37(34.9)	

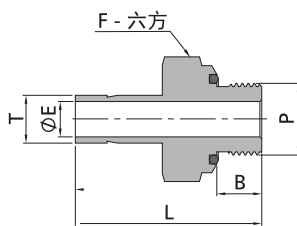

英制 Tube 管				SAE/MS 直螺纹 (STO)			
T-Tube 管外径 (in.)	P-SAE 名义尺寸	P-SAE/MS 螺纹规格	基本 订购号	尺寸, in. (mm)			
				L	B	E*	F
1/8	2	5/16-24	-S-FT2STO5	1.28(32.5)	0.34(8.6)	0.08(2.0)	0.56(14.3)
3/16	3	3/8-24	-S-FT3STO6	1.38(35.1)	0.38(9.7)	0.12(3.0)	0.63(15.9)
1/4	4	7/16-20	-S-FT4STO7	1.54(39.1)	0.41(10.4)	0.17(4.3)	0.75(19.1)
5/16	5	1/2-20	-S-FT5STO8	1.64(41.7)	0.44(11.2)	0.22(5.6)	0.87(22.2)
3/8	6	9/16-18	-S-FT6STO9	1.70(43.2)	0.47(11.9)	0.27(6.9)	0.94(23.8)
1/2	8	3/4-16	-S-FT8STO12	1.95(49.5)	0.47(11.9)	0.37(9.4)	1.13(28.6)

◆ 尺寸"E"为最小公称孔口,此孔口在管螺纹端、直螺纹端可能会更大。

▶ 卡套管-阳螺纹

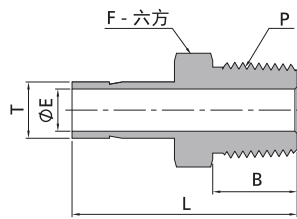

25 mm 及以下

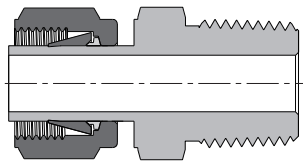

28 mm 及以上

公制 Tube 管			NPT 螺纹			
T-Tube 管外径 (mm)	P-NPT 尺寸	基本 订购号	尺寸, mm (in.)			
			L	B	E *	F
3	1/8	-S-MT3N2	29.4(1.16)	9.7(0.38)	1.8(0.07)	12.0(0.47)
4	1/8	-S-MT4N2	29.4(1.16)	9.7(0.38)	2.4(0.09)	12.0(0.47)
6	1/8	-S-MT6N2	32.8(1.29)	9.7(0.38)	4.1(0.16)	12.0(0.47)
6	1/4	-S-MT6N4	38.1(1.50)	14.2(0.56)	4.1(0.16)	14.0(0.55)
6	3/8	-S-MT6N6	39.2(1.54)	14.2(0.56)	4.1(0.16)	18.0(0.71)
6	1/2	-S-MT6N8	42.1(1.66)	19.1(0.75)	4.1(0.16)	22.0(0.87)
8	1/4	-S-MT8N4	39.1(1.54)	14.2(0.56)	5.6(0.22)	14.0(0.55)
8	3/8	-S-MT8N6	39.9(1.57)	14.2(0.56)	5.6(0.22)	19.0(0.75)
10	1/4	-S-MT10N4	39.9(1.57)	14.2(0.56)	7.1(0.28)	14.0(0.55)
10	3/8	-S-MT10N6	40.6(1.60)	14.2(0.56)	7.1(0.28)	18.0(0.71)
10	1/2	-S-MT10N8	46.2(1.82)	19.1(0.75)	7.1(0.28)	22.0(0.87)
12	1/4	-S-MT12N4	46.5(1.83)	14.2(0.56)	7.1(0.28)	14.0(0.55)
12	3/8	-S-MT12N6	46.2(1.82)	14.2(0.56)	8.8(0.35)	18.0(0.71)
12	1/2	-S-MT12N8	52.1(2.05)	19.1(0.75)	8.8(0.35)	22.0(0.87)
16	1/2	-S-MT16N8	50.8(2.00)	19.1(0.75)	11.9(0.47)	22.0(0.87)
16	3/4	-S-MT16N12	51.6(2.03)	19.1(0.75)	12.0(0.47)	27.0(1.06)
18	1/2	-S-MT18N8	50.8(2.00)	19.1(0.75)	11.9(0.47)	27.0(1.06)
18	3/4	-S-MT18N12	51.6(2.03)	19.1(0.75)	14.0(0.55)	27.0(1.06)
20	1/2	-S-MT20N8	53.3(2.10)	19.1(0.75)	11.9(0.47)	22.0(0.87)
20	3/4	-S-MT20N12	53.8(2.12)	19.1(0.75)	15.5(0.61)	27.0(1.06)
25	1	-S-MT25N16	65.9(2.59)	23.9(0.94)	19.8(0.78)	35.0(1.38)
28	1	-S-AMT28N16	74.7(2.94)	23.9(0.94)	22.2(0.87)	35.0(1.38)
28	1 1/4	-S-AMT28N20	76.2(3.00)	23.9(0.94)	22.5(0.89)	46.0(1.81)
30	1	-S-AMT30N16	79.2(3.12)	23.9(0.94)	22.2(0.87)	41.0(1.61)
30	1 1/4	-S-AMT30N20	80.0(3.15)	23.9(0.94)	24.3(0.96)	46.0(1.81)
32	1 1/4	-S-AMT32N20	81.0(3.19)	23.9(0.94)	26.5(1.04)	46.0(1.81)
38	1 1/2	-S-AMT38N24	92.2(3.63)	26.2(1.03)	31.6(1.24)	55.0(2.17)

公制 Tube 管			ISO 锥螺纹 (RT)			
T-Tube 管外径 (mm)	P-RT 尺寸	基本 订购号	尺寸, mm (in.)			
			L	B	E *	F
3	1/8	-S-MT3RT2	29.4(1.16)	9.7(0.38)	1.8(0.07)	12.0(0.47)
4	1/8	-S-MT4RT2	29.4(1.16)	9.7(0.38)	2.4(0.09)	12.0(0.47)
6	1/8	-S-MT6RT2	32.8(1.29)	9.7(0.38)	4.1(0.16)	12.0(0.47)
6	1/4	-S-MT6RT4	38.1(1.50)	14.2(0.56)	4.1(0.16)	14.0(0.55)
8	1/4	-S-MT8RT4	39.1(1.54)	14.2(0.56)	5.6(0.22)	14.0(0.55)
8	3/8	-S-MT8RT6	39.9(1.57)	14.2(0.56)	5.6(0.22)	19.0(0.75)
10	1/4	-S-MT10RT4	39.9(1.57)	14.2(0.56)	7.1(0.28)	14.0(0.55)
10	3/8	-S-MT10RT6	40.6(1.60)	14.2(0.56)	7.1(0.28)	18.0(0.71)
10	1/2	-S-MT10RT8	44.5(1.75)	19.1(0.75)	7.1(0.28)	22.0(0.87)
12	1/4	-S-MT12RT4	46.5(1.83)	14.2(0.56)	7.1(0.28)	16.0(0.63)
12	3/8	-S-MT12RT6	46.2(1.82)	14.2(0.56)	8.8(0.35)	18.0(0.71)
12	1/2	-S-MT12RT8	51.8(2.04)	19.1(0.75)	8.8(0.35)	22.0(0.87)
16	1/2	-S-MT16RT8	50.8(2.00)	19.1(0.75)	11.9(0.47)	22.0(0.87)
18	3/4	-S-MT18RT12	51.6(2.03)	19.1(0.75)	14.0(0.55)	27.0(1.06)
20	3/4	-S-MT20RT12	52.4(2.06)	19.1(0.75)	15.5(0.61)	27.0(1.06)
25	1	-S-MT25RT16	65.9(2.59)	23.9(0.94)	19.8(0.78)	35.0(1.38)
28	1	-S-AMT28RT16	74.7(2.94)	23.9(0.94)	22.2(0.87)	35.0(1.38)
28	1 1/4	-S-AMT28RT20	76.2(3.00)	23.9(0.94)	22.5(0.89)	46.0(1.81)
30	1 1/4	-S-AMT30RT20	80.0(3.15)	23.9(0.94)	24.3(0.96)	46.0(1.81)
32	1 1/4	-S-AMT32RT20	81.0(3.19)	23.9(0.94)	26.5(1.04)	46.0(1.81)
38	1 1/2	-S-AMT38RT24	92.2(3.63)	26.2(1.03)	31.6(1.24)	55.0(2.17)

◆ 尺寸“E”为最小公称孔口,此孔口在管螺纹端、直螺纹端可能会更大。

► 卡套管-阳螺纹

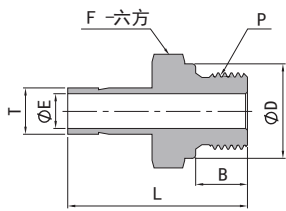

25 mm 及以下

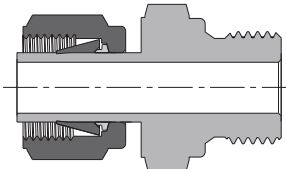

28 mm 及以上

公制 Tube 管			ISO 平行螺纹 (BS)				
T-Tube 管外径 (mm)	P-BS 尺寸	基本 订购号	尺寸, mm (in.)				
			L	B	E*	F	D
3	1/8	-S-MT3BS2	31.0(1.22)	7.1(0.28)	1.8(0.07)	14.0(0.55)	13.7(0.54)
4	1/8	-S-MT4BS2	31.8(1.25)	7.1(0.28)	2.4(0.09)	14.0(0.55)	13.7(0.54)
6	1/8	-S-MT6BS2	34.3(1.35)	7.1(0.28)	4.0(0.16)	14.0(0.55)	13.7(0.54)
6	1/4	-S-MT6BS4	39.1(1.54)	11.2(0.44)	4.1(0.16)	19.0(0.75)	17.8(0.70)
8	1/4	-S-MT8BS4	39.6(1.56)	11.2(0.44)	5.6(0.22)	19.0(0.75)	17.8(0.70)
10	1/4	-S-MT10BS4	40.9(1.61)	11.2(0.44)	5.9(0.23)	19.0(0.75)	17.8(0.70)
10	3/8	-S-MT10BS6	41.7(1.64)	11.2(0.44)	7.1(0.28)	22.0(0.87)	21.6(0.85)
10	1/2	-S-MT10BS8	44.7(1.76)	14.2(0.56)	7.1(0.28)	27.0(1.06)	25.9(1.02)
12	1/4	-S-MT12BS4	46.7(1.84)	11.2(0.44)	5.9(0.23)	19.0(0.75)	17.8(0.70)
12	3/8	-S-MT12BS6	47.2(1.86)	11.2(0.44)	7.9(0.31)	22.0(0.87)	21.6(0.85)
12	1/2	-S-MT12BS8	50.5(1.99)	14.2(0.56)	8.8(0.35)	27.0(1.06)	25.9(1.02)
16	1/2	-S-MT16BS8	50.8(2.00)	14.2(0.56)	11.9(0.47)	27.0(1.06)	25.9(1.02)
18	3/4	-S-MT18BS12	55.9(2.20)	16.0(0.63)	13.9(0.55)	35.0(1.38)	32.0(1.26)
20	3/4	-S-MT20BS12	57.0(2.24)	16.0(0.63)	15.5(0.61)	35.0(1.38)	32.0(1.26)
25	1	-S-MT25BS16	65.1(2.56)	18.3(0.72)	19.8(0.78)	41.0(1.61)	38.9(1.53)
28	1	-S-AMT28BS16	71.9(2.83)	18.3(0.72)	19.8(0.78)	41.0(1.61)	38.9(1.53)
28	1 1/4	-S-AMT28BS20	77.0(3.03)	19.8(0.78)	22.5(0.89)	50.0(1.97)	49.0(1.93)
30	1 1/4	-S-AMT30BS20	80.8(3.18)	19.8(0.78)	24.3(0.96)	50.0(1.97)	49.0(1.93)
32	1 1/4	-S-AMT32BS20	81.8(3.22)	19.8(0.78)	26.5(1.04)	50.0(1.97)	49.0(1.93)
38	1 1/2	-S-AMT38BS24	94.5(3.72)	20.6(0.81)	31.6(1.24)	55.0(2.17)	54.7(2.15)

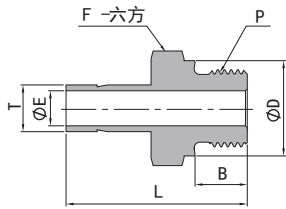

25 mm 及以下

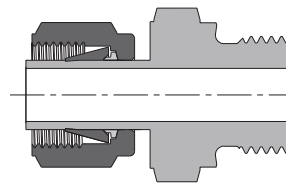

28 mm 及以上

公制 Tube 管			ISO 平行螺纹 (BR)				
T-Tube 管外径 (mm)	P-BR 尺寸	基本 订购号	尺寸, mm (in.)				
			L	B	E*	F	D
3	1/8	-S-MT3BR2	31.0(1.22)	7.1(0.28)	1.8(0.07)	14.0(0.55)	13.7(0.54)
4	1/8	-S-MT4BR2	31.8(1.25)	7.1(0.28)	2.0(0.08)	14.0(0.55)	13.7(0.54)
6	1/8	-S-MT6BR2	34.3(1.35)	7.1(0.28)	4.0(0.16)	14.0(0.55)	13.7(0.54)
6	1/4	-S-MT6BR4	38.1(1.50)	11.2(0.44)	4.0(0.16)	19.0(0.75)	17.8(0.70)
8	1/4	-S-MT8BR4	38.9(1.53)	11.2(0.44)	5.6(0.22)	19.0(0.75)	17.8(0.70)
10	1/4	-S-MT10BR4	38.9(1.53)	11.2(0.44)	6.4(0.25)	19.0(0.75)	17.8(0.70)
10	3/8	-S-MT10BR6	39.7(1.56)	11.2(0.44)	7.1(0.28)	22.0(0.87)	21.6(0.85)
10	1/2	-S-MT10BR8	42.9(1.69)	14.2(0.56)	7.1(0.28)	27.0(1.06)	25.9(1.02)
12	1/4	-S-MT12BR4	43.7(1.72)	11.2(0.44)	6.4(0.25)	19.0(0.75)	17.8(0.70)
12	3/8	-S-MT12BR6	44.5(1.75)	11.2(0.44)	7.9(0.31)	22.0(0.87)	21.6(0.85)
12	1/2	-S-MT12BR8	49.2(1.94)	14.2(0.56)	9.1(0.36)	27.0(1.06)	25.9(1.02)
16	1/2	-S-MT16BR8	50.8(2.00)	14.2(0.56)	11.9(0.47)	27.0(1.06)	25.9(1.02)
18	3/4	-S-MT18BR12	53.2(2.09)	16.0(0.63)	14.0(0.55)	33.0(1.30)	32.0(1.26)
20	3/4	-S-MT20BR12	54.0(2.13)	16.0(0.63)	15.5(0.61)	33.0(1.30)	32.0(1.26)
25	1	-S-MT25BR16	65.1(2.56)	18.3(0.72)	19.8(0.78)	41.0(1.61)	38.9(1.53)
28	1	-S-AMT28BR16	72.7(2.86)	18.3(0.72)	19.8(0.78)	41.0(1.61)	38.9(1.53)
28	1 1/4	-S-AMT28BR20	77.3(3.04)	19.8(0.78)	22.5(0.89)	50.0(1.97)	49.0(1.93)
30	1 1/4	-S-AMT30BR20	80.8(3.18)	19.8(0.78)	24.3(0.96)	50.0(1.97)	49.0(1.93)
32	1 1/4	-S-AMT32BR20	82.1(3.23)	19.8(0.78)	26.5(1.04)	50.0(1.97)	49.0(1.93)
38	1 1/2	-S-AMT38BR24	94.5(3.72)	20.6(0.81)	31.6(1.24)	55.0(2.17)	54.7(2.15)

◆ 尺寸"E"为最小公称孔口,此孔口在管螺纹端、直螺纹端可能会更大。

▶ 卡套管-阴螺纹

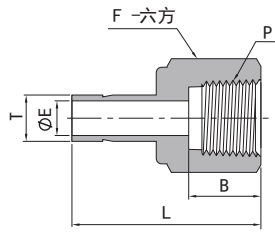

1" 及以下

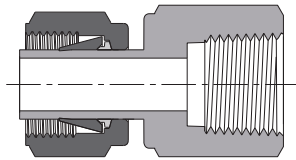

1 1/4"及以上

英制 Tube 管			NPT 螺纹			
T-Tube 管外径 (in.)	P-NPT 尺寸	基本 订购号	尺寸, in. (mm)			
			L	B	E	F
1/16	1/8	-S-FT1FN2	1.07(27.2)	0.41(10.4)	0.03(0.8)	0.56(14.3)
1/8	1/8	-S-FT2FN2	1.24(31.5)	0.41(10.4)	0.08(2.0)	0.56(14.3)
1/8	1/4	-S-FT2FN4	1.39(35.3)	0.59(15.0)	0.08(2.0)	0.75(19.1)
3/16	1/8	-S-FT3FN2	1.25(31.8)	0.41(10.4)	0.11(2.9)	0.56(14.3)
3/16	1/4	-S-FT3FN4	1.41(35.8)	0.59(15.0)	0.12(3.0)	0.75(19.1)
1/4	1/8	-S-FT4FN2	1.30(33.0)	0.41(10.4)	0.17(4.3)	0.56(14.3)
1/4	1/4	-S-FT4FN4	1.46(37.1)	0.59(15.0)	0.17(4.3)	0.75(19.1)
1/4	3/8	-S-FT4FN6	1.55(39.4)	0.59(15.0)	0.17(4.3)	0.87(22.2)
1/4	1/2	-S-FT4FN8	1.79(45.5)	0.78(19.8)	0.17(4.3)	1.06(27.0)
5/16	1/8	-S-FT5FN2	1.34(34.0)	0.41(10.4)	0.22(5.6)	0.56(14.3)
5/16	1/4	-S-FT5FN4	1.48(37.6)	0.59(15.0)	0.22(5.6)	0.75(19.1)
5/16	3/8	-S-FT5FN6	1.59(40.4)	0.59(15.0)	0.22(5.6)	0.87(22.2)
3/8	1/8	-S-FT6FN2	1.35(34.3)	0.41(10.4)	0.27(6.9)	0.56(14.3)
3/8	1/4	-S-FT6FN4	1.50(38.1)	0.59(15.0)	0.27(6.9)	0.75(19.1)
3/8	3/8	-S-FT6FN6	1.59(40.4)	0.59(15.0)	0.27(6.9)	0.87(22.2)
3/8	1/2	-S-FT6FN8	1.84(46.7)	0.78(19.8)	0.27(6.9)	1.06(27.0)
1/2	1/4	-S-FT8FN4	1.71(43.4)	0.59(15.0)	0.37(9.4)	0.75(19.1)
1/2	3/8	-S-FT8FN6	1.79(45.5)	0.59(15.0)	0.37(9.4)	0.87(22.2)
1/2	1/2	-S-FT8FN8	2.04(51.8)	0.78(19.8)	0.37(9.4)	1.06(27.0)
5/8	3/8	-S-FT10FN6	1.86(47.2)	0.59(15.0)	0.47(11.9)	0.87(22.2)
5/8	1/2	-S-FT10FN8	2.09(53.1)	0.78(19.8)	0.47(11.9)	1.06(27.0)
3/4	1/2	-S-FT12FN8	2.08(52.8)	0.78(19.8)	0.58(14.7)	1.06(27.0)
3/4	3/4	-S-FT12FN12	2.16(54.9)	0.81(20.6)	0.58(14.7)	1.31(33.3)
3/4	1	-S-FT12FN16	2.30(58.4)	1.00(25.4)	0.58(14.7)	1.63(41.3)
7/8	3/4	-S-FT14FN12	2.22(56.4)	0.81(20.6)	0.69(17.5)	1.31(33.3)
1	3/4	-S-FT16FN12	2.39(60.7)	0.81(20.6)	0.80(20.3)	1.31(33.3)
1	1	-S-FT16FN16	2.53(64.3)	1.00(25.4)	0.80(20.3)	1.63(41.3)
1 1/4	1 1/4	-S-AFT20FN20	3.06(77.7)	1.00(25.4)	1.02(25.9)	2.13(54.0)
1 1/2	1 1/2	-S-AFT24FN24	3.50(88.9)	1.09(27.7)	1.25(31.8)	2.37(60.3)

英制 Tube 管			ISO 锥螺纹 (RT)			
T-Tube 管外径 (in.)	P-RT 尺寸	基本 订购号	尺寸, in. (mm)			
			L	B	E	F
1/4	1/8	-S-FT4FRT2	1.30(33.0)	0.41(10.4)	0.17(4.3)	0.56(14.3)
1/4	1/4	-S-FT4FRT4	1.45(36.8)	0.59(15.0)	0.17(4.3)	0.75(19.1)
3/8	1/4	-S-FT6FRT4	1.50(38.1)	0.59(15.0)	0.27(6.9)	0.75(19.1)
3/8	3/8	-S-FT6FRT6	1.59(40.4)	0.59(15.0)	0.27(6.9)	0.87(22.2)
1/2	1/4	-S-FT8FRT4	1.71(43.4)	0.59(15.0)	0.37(9.4)	0.75(19.1)
1/2	3/8	-S-FT8FRT6	1.80(45.7)	0.59(15.0)	0.37(9.4)	0.87(22.2)
1/2	1/2	-S-FT8FRT8	2.05(52.1)	0.78(19.8)	0.37(9.4)	1.06(27.0)

► 卡套管-阴螺纹

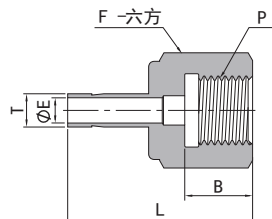
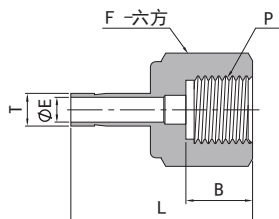
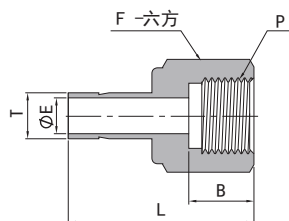

◆ 转接至日本压力表螺栓。

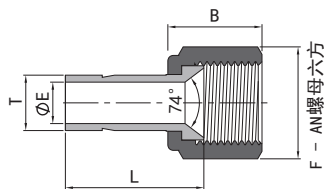

英制 Tube 管			ISO 平行螺纹 (FP)			
T-Tube 管外径 (in.)	P-BR 尺寸	基本 订购号	尺寸, in. (mm)			
			L	B	E	F
1/8	1/8	-S-FT2FP2	1.17(29.7)	0.40(10.2)	0.08(2.0)	0.56(14.3)
1/4	1/8	-S-FT4FP2	1.25(31.8)	0.40(10.2)	0.17(4.3)	0.56(14.3)
1/4	1/4	-S-FT4FP4	1.50(38.1)	0.61(15.5)	0.17(4.3)	0.75(19.1)
3/8	1/4	-S-FT6FP4	1.55(39.4)	0.61(15.5)	0.27(6.9)	0.75(19.1)
3/8	3/8	-S-FT6FP6	1.57(39.9)	0.60(15.2)	0.27(6.9)	0.94(23.8)
1/2	3/8	-S-FT8FP6	1.78(45.2)	0.60(15.2)	0.38(9.7)	0.94(23.8)
1/2	1/2	-S-FT8FP8	1.95(49.5)	0.73(18.5)	0.38(9.7)	1.06(27.0)

英制 Tube 管			ISO 平行螺纹 (FG)			
T-Tube 管外径 (in.)	P-RG 尺寸	基本 订购号	尺寸, in. (mm)			
			L	B	E	F
1/4	1/4	-S-FT4FG4	1.39(35.3)	0.51(12.9)	0.17(4.3)	0.75(19.1)
3/8	3/8	-S-FT6FG6	1.55(39.4)	0.56(14.2)	0.26(6.6)	0.94(23.8)
1/2	1/2	-S-FT8FG8	1.80(45.7)	0.74(18.8)	0.28(7.1)	1.06(27.0)

英制 Tube 管			ISO 平行螺纹 (RJ)			
T-Tube 管外径 (in.)	P-RJ 尺寸	基本 订购号	尺寸, in. (mm)			
			L	B	E	F
1/4	1/4	-S-FT4RJ4	1.39(35.3)	0.51(12.9)	0.17(4.3)	0.75(19.1)
3/8	3/8	-S-FT6RJ6	1.55(39.4)	0.62(15.8)	0.26(6.6)	0.94(23.8)
1/2	1/2	-S-FT8RJ8	1.94(49.3)	0.74(18.8)	0.28(7.1)	1.06(27.0)

英制 Tube 管			AN 螺纹			
T-Tube 管外径 (in.)	AN Tube 管扩口 尺寸(in.)	基本 订购号	尺寸, in. (mm)			
			L	B	E	F
1/8	1/8	-S-FT2FAN2	0.88(22.4)	0.55(14.0)	0.08(2.0)	0.37(9.5)
1/8	1/4	-S-FT2FAN4	0.88(22.4)	0.62(15.8)	0.09(2.4)	0.56(14.3)
1/4	1/4	-S-FT4FAN4	0.96(24.4)	0.62(15.8)	0.16(4.0)	0.56(14.3)
3/8	3/8	-S-FT6FAN6	0.98(24.9)	0.73(18.5)	0.27(6.8)	0.75(19.05)
1/2	1/2	-S-FT8FAN8	1.42(36.1)	0.85(21.6)	0.37(9.4)	0.87(22.2)
3/4	3/4	-S-FT12FAN12	1.49(37.8)	1.03(26.2)	0.58(14.7)	1.25(31.8)

▶ 卡套管-阴螺纹

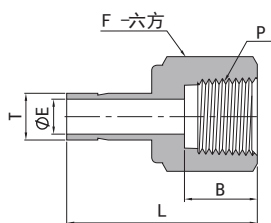

公制 Tube 管			NPT 螺纹			
T-Tube 管外径 (mm)	P-NPT 尺寸	基本 订购号	尺寸, mm (in.)			
			L	B	E	F
3	1/8	-S-MT3FN2	28.8(1.13)	10.4(0.41)	1.3(0.05)	14.0(0.55)
4	1/8	-S-MT4FN2	33.3(1.31)	10.4(0.41)	2.4(0.09)	14.0(0.55)
6	1/8	-S-MT6FN2	32.5(1.28)	10.4(0.41)	4.1(0.16)	14.0(0.55)
6	1/4	-S-MT6FN4	37.1(1.46)	15.0(0.59)	4.1(0.16)	19.0(0.75)
8	1/8	-S-MT8FN2	35.1(1.38)	10.4(0.41)	5.6(0.22)	14.0(0.55)
8	1/4	-S-MT8FN4	37.6(1.48)	15.0(0.59)	5.6(0.22)	19.0(0.75)
8	3/8	-S-MT8FN6	36.5(1.44)	15.0(0.59)	5.6(0.22)	22.0(0.87)
10	1/4	-S-MT10FN4	38.1(1.50)	15.0(0.59)	7.1(0.28)	19.0(0.75)
10	3/8	-S-MT10FN6	40.1(1.58)	15.0(0.59)	7.1(0.28)	22.0(0.87)
10	1/2	-S-MT10FN8	46.5(1.83)	19.8(0.78)	7.1(0.28)	27.0(1.06)
12	1/4	-S-MT12FN4	43.7(1.72)	15.0(0.59)	8.8(0.35)	19.0(0.75)
12	3/8	-S-MT12FN6	42.9(1.69)	15.0(0.59)	8.8(0.35)	22.0(0.87)
12	1/2	-S-MT12FN8	52.3(2.06)	19.8(0.78)	8.8(0.35)	27.0(1.06)
16	1/2	-S-MT16FN8	49.2(1.94)	19.8(0.78)	12.0(0.47)	27.0(1.06)
18	3/4	-S-MT18FN12	52.4(2.06)	20.6(0.81)	14.0(0.55)	32.0(1.26)
20	1/2	-S-MT20FN8	50.0(1.97)	19.8(0.78)	15.5(0.61)	27.0(1.06)
20	3/4	-S-MT20FN12	57.2(2.25)	20.6(0.81)	15.5(0.61)	35.0(1.38)
25	1	-S-MT25FN16	66.7(2.63)	25.4(1.00)	19.8(0.78)	41.0(1.61)

公制 Tube 管			ISO 锥螺纹 (RT)			
T-Tube 管外径 (mm)	P-RT 尺寸	基本 订购号	尺寸, mm (in.)			
			L	B	E	F
3	1/8	-S-MT3FRT2	28.8(1.13)	10.4(0.41)	1.8(0.07)	14.0(0.55)
4	1/8	-S-MT4FRT2	28.6(1.13)	10.4(0.41)	2.4(0.09)	14.0(0.55)
6	1/8	-S-MT6FRT2	33.0(1.30)	10.4(0.41)	4.1(0.16)	14.0(0.55)
8	1/4	-S-MT8FRT4	37.6(1.48)	15.0(0.59)	5.6(0.22)	19.0(0.75)
10	1/4	-S-MT10FRT4	38.1(1.50)	15.0(0.59)	7.1(0.28)	19.0(0.75)
10	3/8	-S-MT10FRT6	36.5(1.44)	15.0(0.59)	7.1(0.28)	22.0(0.87)
10	1/2	-S-MT10FRT8	41.3(1.63)	19.8(0.78)	7.1(0.28)	27.0(1.06)
12	1/4	-S-MT12FRT4	43.7(1.72)	15.0(0.59)	8.8(0.35)	19.0(0.75)
12	3/8	-S-MT12FRT6	43.7(1.72)	15.0(0.59)	8.8(0.35)	22.0(0.87)
12	1/2	-S-MT12FRT8	46.8(1.84)	19.8(0.78)	8.8(0.35)	27.0(1.06)
16	1/2	-S-MT16FRT8	48.4(1.91)	19.8(0.78)	12.0(0.47)	27.0(1.06)
18	3/4	-S-MT18FRT12	52.4(2.06)	20.6(0.81)	14.0(0.55)	32.0(1.26)
20	3/4	-S-MT20FRT12	52.4(2.06)	20.6(0.81)	15.5(0.61)	32.0(1.26)
25	1	-S-MT25FRT16	66.7(2.63)	25.4(1.00)	19.8(0.78)	41.0(1.61)

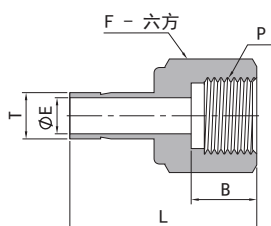

公制 Tube 管			ISO 平行螺纹 (BR)			
T-Tube 管外径 (mm)	P-BR 尺寸	基本 订购号	尺寸, mm (in.)			
			L	B	E	F
6	1/8	-S-MT6FP2	32.0(1.26)	10.2(0.40)	4.1(0.16)	14.0(0.55)
6	1/4	-S-MT6FP4	37.8(1.49)	15.2(0.60)	4.1(0.16)	19.0(0.75)
12	1/2	-S-MT12FP8	49.8(1.96)	18.8(0.74)	8.8(0.35)	27.0(1.06)

► 卡套管-阴螺纹

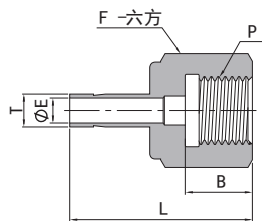
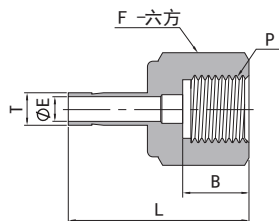

◆ 转接至日本压力表螺栓。

公制 Tube 管			ISO 平行螺纹 (FG)			
T-Tube 管外径 (mm)	P-FG 尺寸	基本 订购号	尺寸, mm (in.)			
			L	B	E	F
3	1/8	-S-MT3FG2	28.6(1.13)	9.8(0.39)	1.9(0.07)	14.0(0.55)
3	1/4	-S-MT3FG4	33.5(1.32)	12.9(0.50)	1.9(0.07)	19.0(0.75)
4	1/8	-S-MT4FG2	29.4(1.16)	9.8(0.39)	2.4(0.09)	14.0(0.55)
6	1/8	-S-MT6FG2	29.1(1.15)	9.8(0.39)	4.1(0.16)	14.0(0.55)
6	1/4	-S-MT6FG4	35.3(1.39)	12.9(0.50)	4.1(0.16)	19.0(0.75)
6	3/8	-S-MT6FG6	38.4(1.51)	14.2(0.56)	4.1(0.16)	24.0(0.94)
6	1/2	-S-MT6FG8	42.9(1.69)	18.8(0.74)	4.1(0.16)	27.0(1.06)
8	1/4	-S-MT8FG4	33.0(1.30)	12.9(0.50)	5.5(0.22)	19.0(0.75)
8	3/8	-S-MT8FG6	38.9(1.53)	14.2(0.56)	5.6(0.22)	24.0(0.94)
8	1/2	-S-MT8FG8	43.7(1.72)	18.8(0.74)	5.6(0.22)	27.0(1.06)
10	1/4	-S-MT10FG4	34.5(1.36)	12.9(0.50)	5.5(0.22)	19.0(0.75)
10	3/8	-S-MT10FG6	36.1(1.42)	14.2(0.56)	6.5(0.26)	24.0(0.94)
10	1/2	-S-MT10FG8	41.1(1.62)	18.8(0.74)	7.1(0.28)	27.0(1.06)
12	1/4	-S-MT12FG4	40.1(1.58)	12.9(0.50)	5.5(0.22)	19.0(0.75)
12	3/8	-S-MT12FG6	44.7(1.76)	14.2(0.56)	6.5(0.26)	24.0(0.94)
12	1/2	-S-MT12FG8	48.8(1.92)	18.8(0.74)	7.0(0.28)	27.0(1.06)
16	1/2	-S-MT16FG8	49.0(1.93)	18.8(0.74)	7.0(0.28)	27.0(1.06)
18	1/2	-S-MT18FG8	49.3(1.94)	18.8(0.74)	7.0(0.28)	27.0(1.06)

公制 Tube 管			ISO 平行螺纹 (RJ)			
T-Tube 管外径 (mm)	P-RJ 尺寸	基本 订购号	尺寸, mm (in.)			
			L	B	E	F
6	1/4	-S-MT6RJ4	35.3(1.39)	12.9(0.50)	4.1(0.16)	19.0(0.75)
6	3/8	-S-MT6RJ6	38.6(1.52)	15.8(0.62)	4.1(0.16)	24.0(0.94)
6	1/2	-S-MT6RJ8	42.9(1.69)	18.8(0.74)	4.1(0.16)	27.0(1.06)
8	1/4	-S-MT8RJ4	33.0(1.30)	12.9(0.50)	5.5(0.22)	19.0(0.75)
8	3/8	-S-MT8RJ6	39.4(1.55)	15.8(0.62)	5.6(0.22)	24.0(0.94)
8	1/2	-S-MT8RJ8	43.7(1.72)	18.8(0.74)	5.6(0.22)	27.0(1.06)
10	1/4	-S-MT10RJ4	34.5(1.36)	12.9(0.50)	5.5(0.22)	19.0(0.75)
10	3/8	-S-MT10RJ6	36.1(1.42)	15.8(0.62)	6.5(0.26)	24.0(0.94)
10	1/2	-S-MT10RJ8	41.1(1.62)	18.8(0.74)	7.1(0.28)	27.0(1.06)
12	1/4	-S-MT12RJ4	40.1(1.58)	12.9(0.50)	5.5(0.22)	19.0(0.75)
12	3/8	-S-MT12RJ6	44.7(1.76)	15.8(0.62)	6.5(0.26)	24.0(0.94)
12	1/2	-S-MT12RJ8	48.8(1.92)	18.8(0.74)	7.0(0.28)	27.0(1.06)

► 卡套管-焊接

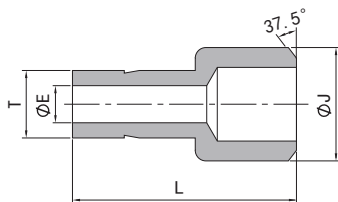

英制 Tube 管			Pipe 管焊接		
T-Tube 管外径 (in.)	Pipe管 焊接尺寸	基本订购号	尺寸, in. (mm)		
			L	J	E
1/4	1/4	-S-FT4PB4	1.14(29.0)	0.54(13.7)	0.17(4.3)
3/8	1/2	-S-FT6PB8	1.46(37.1)	0.84(21.3)	0.27(6.9)
1/2	1/2	-S-FT8PB8	1.66(42.2)	0.84(21.3)	0.37(9.4)
1/2	3/4	-S-FT8PB12	1.68(42.7)	1.05(26.7)	0.37(9.4)
3/4	3/4	-S-FT12PB12	1.87(47.5)	1.05(26.7)	0.58(14.7)

◆ 注: Pipe 管焊接端公称壁厚为 SCH80。

▶ 卡套-法兰

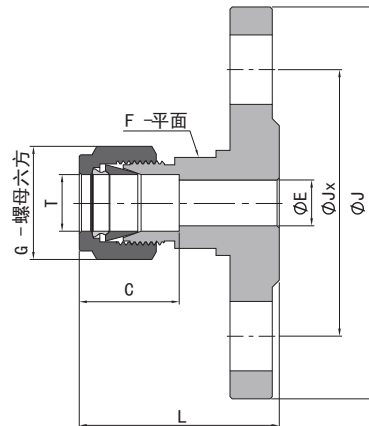

- ◆ 本体整体锻造。
- ◆ ASME 法兰遵照标准ASME B16.5。
- ◆ DIN 法兰遵照标准DIN 2501/2526。
- ◆ GB 法兰遵照标准GB/T 9123.1。
- ◆ EN 法兰遵照标准EN 1092-1。
- ◆ JIS 法兰遵照标准JIS B 2220。

ASME 法兰										
T-Tube 管外径 (in.)	ASME 法兰 NPS	Class	突面法兰 基本订购号	尺寸, in. (mm)						
				L	J	Jx	E	C	G	F
1/4	1/2	150	-FL-FJ4F8-150	1.61(40.9)	3.50(88.9)	2.38(60.5)	0.19(4.8)	0.60(15.2)	0.56(14.3)	0.81(20.6)
3/8	1/2	300	-FL-FJ6F8-300	1.79(45.5)	3.75(95.3)	2.62(66.5)	0.28(7.1)	0.66(16.8)	0.69(17.5)	0.81(20.6)
1/2	1/2	150	-FL-FJ8F8-150	1.78(45.2)	3.50(88.9)	2.38(60.5)	0.41(10.4)	0.90(22.9)	0.87(22.2)	0.81(20.6)
1/2	1	150	-FL-FJ8F16-150	1.90(48.3)	4.25(108.0)	3.12(79.2)	0.41(10.4)	0.90(22.9)	0.87(22.2)	0.81(20.6)
1/2	2	150	-FL-FJ8F32-150	2.09(53.1)	6.00(152.4)	4.76(121.0)	0.41(10.4)	0.90(22.9)	0.87(22.2)	0.81(20.6)
3/4	1	150	-FL-FJ12F16-150	1.98(50.3)	4.25(108.0)	3.12(79.2)	0.62(15.7)	0.96(24.4)	1.13(28.6)	1.25(31.8)
1	1	150	-FL-FJ16F16-150	2.38(60.5)	4.25(108.0)	3.12(79.2)	0.88(22.4)	1.23(31.2)	1.50(38.1)	1.37(34.9)

DIN/GB 法兰, 压力等级 PN 40										
T-Tube 管外径 (mm)	DIN 法兰尺寸 DN	突面法兰 基本订购号	尺寸, mm (in.)							
			L	J	Jx	E	C	G	F	
6	25	-FL-MJ6F25-40B1	47.5(1.87)	115.0(4.53)	85.0(3.35)	4.8(0.19)	15.3(0.60)	14.0(0.55)	20.0(0.79)	
12	15	-FL-MJ12F15-40B1	48.5(1.91)	95.0(3.74)	65.0(2.56)	9.5(0.37)	22.8(0.90)	22.0(0.87)	20.0(0.79)	
12	25	-FL-MJ12F25-40B1	50.5(1.99)	115.0(4.53)	85.0(3.35)	9.5(0.37)	22.8(0.90)	22.0(0.87)	20.0(0.79)	
12	50	-FL-MJ12F50-40B1	55.3(2.18)	165.0(6.50)	125.0(4.92)	9.5(0.37)	22.8(0.90)	22.0(0.87)	20.0(0.79)	
18	15	-FL-MJ18F15-40B1	51.8(2.04)	95.0(3.74)	65.0(2.56)	15.1(0.59)	24.4(0.96)	30.0(1.18)	32.0(1.26)	
18	25	-FL-MJ18F25-40B1	53.8(2.12)	115.0(4.53)	85.0(3.35)	15.1(0.59)	24.4(0.96)	30.0(1.18)	32.0(1.26)	
25	25	-FL-MJ25F25-40B1	64.0(2.52)	115.0(4.53)	85.0(3.35)	21.8(0.86)	31.3(1.23)	38.0(1.50)	35.0(1.38)	

▶ 卡套-法兰

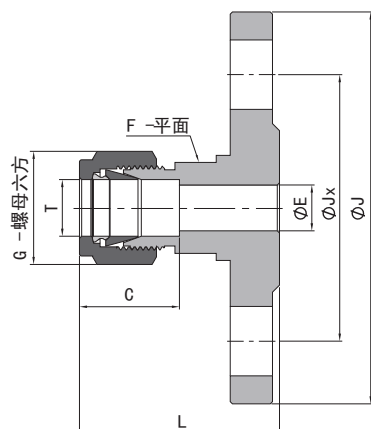

- ◆ 本体整体锻造。
- ◆ ASME 法兰遵照标准ASME B16.5。
- ◆ DIN 法兰遵照标准DIN 2501/2526。
- ◆ GB 法兰遵照标准GB/T 9123.1。
- ◆ EN 法兰遵照标准EN 1092-1。
- ◆ JIS 法兰遵照标准JIS B 2220。

EN 法兰, 压力等级 PN 40									
T-Tube 管外径 (mm)	EN 法兰尺寸 DN	突面法兰 基本订购号	尺寸, mm (in.)						
			L	J	Jx	E	C	G	F
6	25	-FL-MJ6F25E-40B1	47.5(1.87)	115.0(4.53)	85.0(3.35)	4.8(0.19)	15.3(0.60)	14.0(0.55)	20.0(0.79)
12	15	-FL-MJ12F15E-40B1	48.5(1.91)	95.0(3.74)	65.0(2.56)	9.5(0.37)	22.8(0.90)	22.0(0.87)	20.0(0.79)
12	25	-FL-MJ12F25E-40B1	50.5(1.99)	115.0(4.53)	85.0(3.35)	9.5(0.37)	22.8(0.90)	22.0(0.87)	20.0(0.79)
12	50	-FL-MJ12F50E-40B1	55.3(2.18)	165.0(6.50)	125.0(4.92)	9.5(0.37)	22.8(0.90)	22.0(0.87)	20.0(0.79)
18	15	-FL-MJ18F15E-40B1	51.8(2.04)	95.0(3.74)	65.0(2.56)	15.1(0.59)	24.4(0.96)	30.0(1.18)	32.0(1.26)
18	25	-FL-MJ18F25E-40B1	53.8(2.12)	115.0(4.53)	85.0(3.35)	15.1(0.59)	24.4(0.96)	30.0(1.18)	32.0(1.26)
25	25	-FL-MJ25F25E-40B1	64.0(2.52)	115.0(4.53)	85.0(3.35)	21.8(0.86)	31.3(1.23)	38.0(1.50)	35.0(1.38)

JIS 法兰, 压力等级 10K									
T-Tube 管外径	JIS 法兰尺寸 DN	突面法兰 基本订购号	尺寸, in. (mm)						
			L	J	Jx	E	C	G	F
1/4"	15	-FL-FJ4F15-10KRF	1.66(42.2)	3.74(95.0)	2.76(70.1)	0.19(4.8)	0.60(15.2)	0.56(14.3)	0.81(20.6)
3/8"	15	-FL-FJ6F15-10KRF	1.72(43.7)	3.74(95.0)	2.76(70.1)	0.28(7.1)	0.66(16.8)	0.69(17.5)	0.81(20.6)
1/2"	15	-FL-FJ8F15-10KRF	1.83(46.5)	3.74(95.0)	2.76(70.1)	0.41(10.4)	0.90(22.9)	0.87(22.2)	0.81(20.6)
3/4"	15	-FL-FJ12F15-10KRF	1.91(48.5)	3.74(95.0)	2.76(70.1)	0.62(15.7)	0.96(24.4)	1.13(28.6)	1.25(31.8)
1"	25	-FL-FJ16F25-10KRF	2.40(61.0)	4.92(125.0)	3.54(89.9)	0.88(22.4)	1.23(31.2)	1.50(38.1)	1.37(34.9)
12mm	15	-FL-MJ12F15-10KRF	1.83(46.5)	3.74(95.0)	2.76(70.0)	0.37(9.5)	0.90(22.8)	0.87(22.0)	0.79(20.0)
18mm	15	-FL-MJ18F15-10KRF	1.91(48.5)	3.74(95.0)	2.76(70.0)	0.59(15.1)	0.96(24.4)	1.18(30.0)	1.26(32.0)
25mm	25	-FL-MJ25F25-10KRF	2.40(61.0)	4.92(125.0)	3.54(90.0)	0.86(21.8)	1.23(31.3)	1.50(38.0)	1.38(35.0)

▶ 卡套焊接接头

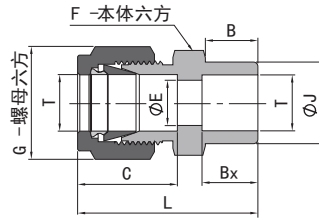

英制 Tube 管			Tube 管插焊						
T-Tube 管外径 (in.)	基本 订购号	尺寸, in. (mm)							
		L	C	G	F	B	E	Bx	J
1/8	-S-FJ2TS2	1.14(29.0)	0.50(12.7)	0.44(11.1)	0.44(11.1)	0.34(8.6)	0.09(2.3)	0.10(2.5)	0.31(7.9)
3/16	-S-FJ3TS3	1.17(29.7)	0.54(13.7)	0.50(12.7)	0.44(11.1)	0.37(9.5)	0.13(3.3)	0.19(4.8)	0.42(10.7)
1/4	-S-FJ4TS4	1.32(33.5)	0.60(15.2)	0.56(14.3)	0.50(12.7)	0.41(10.4)	0.19(4.8)	0.28(7.1)	0.48(12.2)
3/8	-S-FJ6TS6	1.48(37.6)	0.66(16.8)	0.69(17.5)	0.63(15.9)	0.47(11.9)	0.28(7.1)	0.31(7.9)	0.62(15.7)
1/2	-S-FJ8TS8	1.62(41.1)	0.90(22.9)	0.87(22.2)	0.81(20.6)	0.47(11.9)	0.41(10.4)	0.38(9.7)	0.73(18.5)
5/8	-S-FJ10TS10	1.65(41.9)	0.96(24.4)	1.00(25.4)	0.94(23.8)	0.47(11.9)	0.50(12.7)	0.41(10.4)	0.92(23.4)
3/4	-S-FJ12TS12	1.71(43.4)	0.96(24.4)	1.13(28.6)	1.06(27.0)	0.47(11.9)	0.62(15.7)	0.44(11.1)	1.05(26.7)
1	-S-FJ16TS16	2.07(52.6)	1.23(31.2)	1.50(38.1)	1.37(34.9)	0.56(14.2)	0.88(22.4)	0.62(15.7)	1.36(34.5)

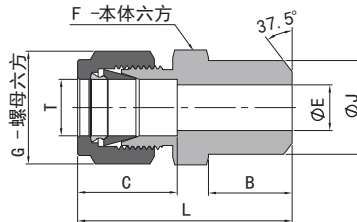

◆ 尺寸"E"为最小公称孔口,此孔口在管螺纹端、直螺纹端可能会更大。

英制 Tube 管			Pipe 管对焊						
T-Tube 管外径 (in.)	Pipe管 焊接尺寸	基本 订购号	尺寸, in. (mm)						
			L	C	G	F	E*	B	J
1/8	1/8	-S-FJ2PB2	1.20(30.5)	0.50(12.7)	0.44(11.1)	0.44(11.1)	0.09(2.3)	0.38(9.7)	0.41(10.3)
3/16	1/8	-S-FJ3PB2	1.23(31.2)	0.54(13.7)	0.50(12.7)	0.44(11.1)	0.12(3.0)	0.38(9.7)	0.41(10.3)
1/4	1/8	-S-FJ4PB2	1.29(32.8)	0.60(15.2)	0.56(14.3)	0.50(12.7)	0.19(4.8)	0.38(9.7)	0.41(10.3)
1/4	1/4	-S-FJ4PB4	1.49(37.8)	0.60(15.2)	0.56(14.3)	0.56(14.3)	0.19(4.8)	0.56(14.2)	0.54(13.7)
5/16	1/8	-S-FJ5PB2	1.34(34.0)	0.64(16.3)	0.63(15.9)	0.56(14.3)	0.21(5.3)	0.38(9.7)	0.41(10.3)
5/16	1/4	-S-FJ5PB4	1.52(38.6)	0.64(16.3)	0.63(15.9)	0.56(14.3)	0.25(6.4)	0.56(14.2)	0.54(13.7)
3/8	1/4	-S-FJ6PB4	1.57(39.9)	0.66(16.8)	0.69(17.5)	0.63(15.9)	0.28(7.1)	0.56(14.2)	0.54(13.7)
3/8	3/8	-S-FJ6PB6	1.57(39.9)	0.66(16.8)	0.69(17.5)	0.69(17.5)	0.28(7.1)	0.56(14.2)	0.67(17.1)
3/8	1/2	-S-FJ6PB8	1.82(46.2)	0.66(16.8)	0.69(17.5)	0.87(22.2)	0.28(7.1)	0.75(19.1)	0.84(21.3)
3/8	3/4	-S-FJ6PB12	1.88(47.8)	0.66(16.8)	0.69(17.5)	1.06(27.0)	0.28(7.1)	0.75(19.1)	1.05(26.7)
1/2	3/8	-S-FJ8PB6	1.71(43.4)	0.90(22.9)	0.87(22.2)	0.81(20.6)	0.41(10.4)	0.56(14.2)	0.67(17.1)
1/2	1/2	-S-FJ8PB8	1.93(49.0)	0.90(22.9)	0.87(22.2)	0.87(22.2)	0.41(10.4)	0.75(19.1)	0.84(21.3)
1/2	3/4	-S-FJ8PB12	1.99(50.5)	0.90(22.9)	0.87(22.2)	1.06(27.0)	0.41(10.4)	0.75(19.1)	1.05(26.7)
5/8	1/2	-S-FJ10PB8	1.93(49.0)	0.96(24.4)	1.00(25.4)	0.94(23.8)	0.50(12.7)	0.75(19.1)	0.84(21.3)
3/4	1/2	-S-FJ12PB8	1.99(50.5)	0.96(24.4)	1.13(28.6)	1.06(27.0)	0.55(14.0)	0.75(19.1)	0.84(21.3)
3/4	3/4	-S-FJ12PB12	1.99(50.5)	0.96(24.4)	1.13(28.6)	1.06(27.0)	0.62(15.7)	0.75(19.1)	1.05(26.7)
1	1	-S-FJ16PB16	2.45(62.2)	1.23(31.2)	1.50(38.1)	1.37(34.9)	0.88(22.4)	0.94(23.9)	1.31(33.4)
1 1/4	1 1/4	-S-FJ20PB20	3.04(77.2)	1.62(41.1)	1.87(47.6)	1.75(44.5)	1.09(27.7)	0.94(23.9)	1.66(42.2)
1 1/2	1 1/2	-S-FJ24PB24	3.50(88.9)	1.97(50.0)	2.25(57.2)	2.13(54.0)	1.34(34.0)	1.03(26.2)	1.90(48.3)

▶ 卡套焊接接头

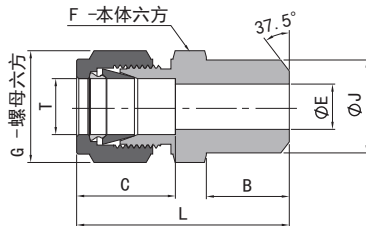

◆ 尺寸“E”为最小公称孔口,此孔口在管螺纹端、直螺纹端可能会更大。

公制 Tube 管			Pipe 管对焊						
T-Tube 管外径 (mm)	Pipe管 焊接尺寸	基本订购号	尺寸, mm (in.)						
			L	C	G	F	E*	B	J
3	1/8	-S-MJ3PB2	30.5(1.20)	12.9(0.51)	12.0(0.47)	12.0(0.47)	2.4(0.09)	9.7(0.38)	10.3(0.41)
4	1/8	-S-MJ4PB2	31.5(1.24)	13.7(0.54)	12.0(0.47)	12.0(0.47)	2.4(0.09)	9.7(0.38)	10.3(0.41)
6	1/8	-S-MJ6PB2	32.8(1.29)	15.3(0.60)	14.0(0.55)	14.0(0.55)	4.8(0.19)	9.7(0.38)	10.3(0.41)
6	1/4	-S-MJ6PB4	37.9(1.49)	15.3(0.60)	14.0(0.55)	14.0(0.55)	4.8(0.19)	14.2(0.56)	13.7(0.54)
8	1/8	-S-MJ8PB2	34.2(1.35)	16.2(0.64)	16.0(0.63)	15.0(0.59)	5.4(0.21)	9.7(0.38)	10.3(0.41)
8	1/4	-S-MJ8PB4	38.7(1.52)	16.2(0.64)	16.0(0.63)	15.0(0.59)	6.4(0.25)	14.2(0.56)	13.7(0.54)
8	1/2	-S-MJ8PB8	45.6(1.80)	16.2(0.64)	16.0(0.63)	22.0(0.87)	6.4(0.25)	19.1(0.75)	21.3(0.84)
10	1/4	-S-MJ10PB4	40.9(1.60)	17.2(0.70)	19.0(0.75)	18.0(0.71)	7.5(0.30)	14.2(0.56)	13.7(0.54)
10	3/8	-S-MJ10PB6	40.9(1.60)	17.2(0.70)	19.0(0.75)	18.0(0.71)	7.9(0.31)	14.2(0.56)	17.1(0.67)
10	1/2	-S-MJ10PB8	46.5(1.80)	17.2(0.70)	19.0(0.75)	22.0(0.87)	7.9(0.31)	19.1(0.75)	21.3(0.84)
12	1/4	-S-MJ12PB4	43.4(1.70)	22.8(0.90)	22.0(0.87)	22.0(0.87)	7.5(0.30)	14.2(0.56)	13.7(0.54)
12	3/8	-S-MJ12PB6	43.4(1.70)	22.8(0.90)	22.0(0.87)	22.0(0.87)	9.5(0.37)	14.2(0.56)	17.1(0.67)
12	1/2	-S-MJ12PB8	49.0(1.90)	22.8(0.90)	22.0(0.87)	22.0(0.87)	9.5(0.37)	19.1(0.75)	21.3(0.84)
14	3/8	-S-MJ14PB6	44.1(1.70)	24.4(0.96)	25.0(0.98)	24.0(0.94)	10.7(0.42)	14.2(0.56)	17.1(0.67)
15	1/2	-S-MJ15PB8	49.0(1.90)	24.4(0.96)	25.0(0.98)	24.0(0.94)	11.9(0.47)	19.1(0.75)	21.3(0.84)
16	1/2	-S-MJ16PB8	49.0(1.90)	24.4(0.96)	25.0(0.98)	24.0(0.94)	12.7(0.50)	19.1(0.75)	21.3(0.84)
18	1/2	-S-MJ18PB8	50.5(2.00)	24.4(0.96)	30.0(1.18)	27.0(1.06)	13.9(0.55)	19.1(0.75)	21.3(0.84)
30	1 1/4	-S-MJ30PB20	77.2(3.00)	39.6(1.60)	50.0(1.97)	46.0(1.81)	26.2(1.03)	23.9(0.94)	42.2(1.66)
32	1 1/4	-S-MJ32PB20	79.6(3.10)	42.0(1.70)	50.0(1.97)	46.0(1.81)	28.6(1.13)	23.9(0.94)	42.2(1.66)
38	1 1/2	-S-MJ38PB24	91.6(3.60)	49.4(1.90)	60.0(2.36)	55.0(2.17)	33.7(1.33)	26.2(1.03)	48.3(1.9)

▶ 卡套焊接弯头

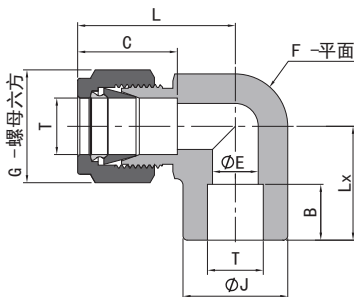

英制 Tube 管		Tube 管插焊							
T-Tube 管外径 (in.)	基本订购号	尺寸, in. (mm)							
		L	C	G	F	B	E	Lx	J
1/8	-L-FJ2TS2	0.66(16.8)	0.50(12.7)	0.44(11.1)	0.37(9.5)	0.10(2.5)	0.09(2.3)	0.63(16.0)	0.43(11.0)
3/16	-L-FJ3TS3	0.72(18.3)	0.54(13.7)	0.50(12.7)	0.44(11.1)	0.19(4.8)	0.13(3.3)	0.69(17.5)	0.58(14.7)
1/4	-L-FJ4TS4	1.06(26.9)	0.60(15.2)	0.56(14.3)	0.50(12.7)	0.28(7.1)	0.19(4.8)	0.77(19.6)	0.58(14.7)
3/8	-L-FJ6TS6	1.20(30.5)	0.66(16.8)	0.69(17.5)	0.63(15.9)	0.31(7.9)	0.28(7.1)	0.91(23.1)	0.72(18.3)
1/2	-L-FJ8TS8	1.42(36.1)	0.90(22.9)	0.87(22.2)	0.81(20.6)	0.38(9.7)	0.41(10.4)	1.02(25.9)	0.94(23.8)
5/8	-L-FJ10TS10	1.16(29.5)	0.96(24.4)	1.00(25.4)	1.06(27.0)	0.41(10.4)	0.50(12.7)	1.16(29.5)	1.08(27.5)
3/4	-L-FJ12TS12	1.57(39.9)	0.96(24.4)	1.13(28.6)	1.06(27.0)	0.44(11.2)	0.62(15.7)	1.17(29.7)	1.23(31.2)
1	-L-FJ16TS16	1.93(49.0)	1.23(31.2)	1.50(38.1)	1.37(34.9)	0.62(15.7)	0.88(22.4)	1.45(36.8)	1.59(40.3)

▶ 卡套焊接弯头

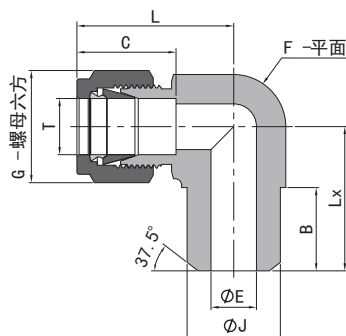

- ◆ 尺寸"E"为最小公称孔口,此孔口在管螺纹端、直螺纹端可能会更大。

英制 Tube 管			Pipe 管对焊							
T-Tube 管外径 (in.)	管 焊接尺寸	基本订购号	尺寸, in. (mm)							
			L	C	G	F	B	E*	Lx	J
1/8	1/8	-L-FJ2PB2	0.92(23.4)	0.50(12.7)	0.44(11.1)	0.44(11.1)	0.38(9.7)	0.09(2.3)	0.72(18.3)	0.41(10.3)
3/16	1/8	-L-FJ3PB2	1.01(25.7)	0.54(13.7)	0.50(12.7)	0.50(12.7)	0.38(9.7)	0.12(3.0)	0.74(18.8)	0.41(10.3)
1/4	1/8	-L-FJ4PB2	1.06(26.9)	0.60(15.2)	0.56(14.3)	0.50(12.7)	0.38(9.7)	0.19(4.8)	0.74(18.8)	0.41(10.3)
1/4	1/4	-L-FJ4PB4	1.06(26.9)	0.60(15.2)	0.56(14.3)	0.50(12.7)	0.56(14.2)	0.19(4.8)	0.92(23.4)	0.54(13.7)
3/8	1/4	-L-FJ6PB4	1.20(30.5)	0.66(16.8)	0.69(17.5)	0.63(15.9)	0.56(14.2)	0.28(7.1)	1.00(25.4)	0.54(13.7)
1/2	3/8	-L-FJ8PB6	1.37(34.8)	0.90(22.9)	0.87(22.2)	0.81(20.6)	0.56(14.2)	0.41(10.4)	1.13(28.8)	0.67(17.1)
1/2	1/2	-L-FJ8PB8	1.42(36.1)	0.90(22.9)	0.87(22.2)	0.81(20.6)	0.75(19.1)	0.41(10.4)	1.30(33.0)	0.84(21.3)
5/8	1/2	-L-FJ10PB8	1.43(36.3)	0.96(24.4)	1.00(25.4)	0.94(23.8)	0.75(19.1)	0.50(12.7)	1.38(35.1)	0.84(21.3)
3/4	3/4	-L-FJ12PB12	1.57(39.9)	0.96(24.4)	1.13(28.6)	1.06(27.0)	0.75(19.1)	0.62(15.7)	1.45(36.8)	1.05(26.7)
1	3/4	-L-FJ16PB12	1.94(49.3)	1.23(31.2)	1.50(38.1)	1.37(34.9)	0.75(19.1)	0.74(18.8)	1.65(41.9)	1.05(26.7)
1	1	-L-FJ16PB16	1.94(49.3)	1.23(31.2)	1.50(38.1)	1.37(34.9)	0.94(23.9)	0.88(22.4)	1.84(46.7)	1.31(33.4)

◆ 注: Pipe 管焊接端公称壁厚为 SCH80。

▶ 卡套校验接头

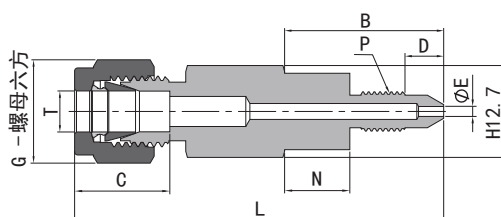

- ◆ 卡套校验接头可以和压力变送器出口直接相连, 安装方便。
- ◆ 两种结构的校验接头可供选择。

T-Tube 管外径 (in.)	P-SAE/MS 螺纹尺寸	基本订购号	尺寸, in. (mm)						
			L	B	C	D	E	G	N
1/4	1/4-28	-S-FJ4-1428	1.69(42.9)	0.78(19.8)	0.60(15.2)	0.43(10.9)	0.06(1.5)	0.56(14.3)	—
1/4	5/16-24	-S-FJ4-51624	2.32(58.9)	1.41(35.8)	0.60(15.2)	0.40(10.2)	0.06(1.5)	0.56(14.3)	0.41(10.4)

▶▶ 卡套绝缘接头

▶ 材料

元件	材料
绝缘体	聚酰胺-酰亚胺
O形圈	70度 FKM
挡圈	纯 PTFE

▶ 技术数据

- ◆ 绝缘体电阻: 在 10 伏直流电、温度为 21°C(70°F), 电阻为 $10 \times 10^9 \Omega$
- ◆ 最大工作压力: 在 21°C(70°F)下, 344 bar (5000 psig)
- ◆ 温度范围: -20°C(-4°F) 至 93°C(200°F)

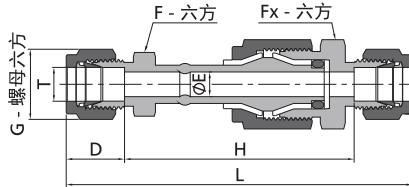

英制 Tube 管								
T-Tube 管外径 (in.)	基本订购号	尺寸, in. (mm)						
		L	D	G	H	E	F	Fx
1/4	-DF-FJ4	3.77(95.7)	0.60(15.2)	0.56(14.3)	2.57(65.3)	0.19(4.8)	0.50(12.7)	0.81(20.6)
3/8	-DF-FJ6	3.92(99.6)	0.66(16.8)	0.69(17.5)	2.59(65.8)	0.28(7.1)	0.63(15.9)	0.81(20.6)
1/2	-DF-FJ8	4.17(106.0)	0.90(22.9)	0.87(22.2)	2.37(60.2)	0.28(7.1)	0.81(20.6)	0.81(20.6)

公制 Tube 管								
T-Tube 管外径 (mm)	基本订购号	尺寸, mm (in.)						
		L	D	G	H	E	F	Fx
12	DF-MJ12	107.0(4.21)	22.8(0.90)	22.0(0.87)	61.7(2.43)	7.1(0.28)	22.0(0.87)	22.0(0.87)

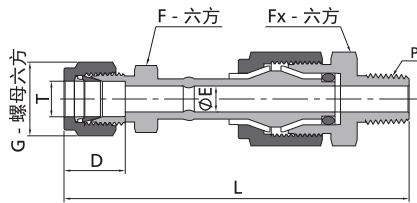

- ◆ 尺寸"E"为最小公称孔口, 此孔口在管螺纹端、直螺纹端可能会更大。

公制 Tube 管			NPT 螺纹					
T-Tube 管外径 (in)	P-NPT 尺寸	基本订购号	尺寸, in. (mm)					
			L	D	G	E*	F	Fx
3/8	1/4	-DF-FJ6N4	3.73(94.7)	0.66(16.8)	0.69(17.5)	0.28(7.1)	0.63(15.9)	0.87(22.2)

► BS、BSD 垫片

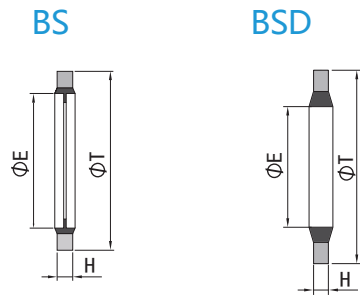

- ◆ BS、BSD 垫片为 ISO 平行阳螺纹提供密封。
- ◆ 垫片由一个碳氟化合物 FKM 或丁腈橡胶内圈和一个碳钢或不锈钢外圈组成。

ISO 平行 螺纹尺寸	基本 订购号	尺寸, in. (mm)		
		T	E	H
1/8	-BS-2	0.63(16.0)	0.41(10.4)	0.08(2.0)
1/4	-BS-4	0.81(20.6)	0.54(13.7)	
3/8	-BS-6	0.94(23.9)	0.68(17.3)	
1/2	-BS-8	1.13(28.7)	0.85(21.6)	0.10(2.5)
3/4	-BS-12	1.38(35.1)	1.06(26.9)	
1	-BS-16	1.69(42.9)	1.33(33.8)	

1/8	-BSD-2	0.58(14.7)	0.41(10.4)	0.05(1.25)
1/4	-BSD-4	0.74(18.7)	0.55(13.9)	
3/8	-BSD-6	0.89(22.7)	0.69(17.4)	
1/2	-BSD-8	1.05(26.7)	0.85(21.7)	
3/4	-BSD-12	1.28(32.5)	1.07(27.3)	
1	-BSD-16	1.56(39.5)	1.35(34.2)	0.08(2.0)

公制螺纹 尺寸	基本 订购号	尺寸, mm (in.)		
		T	E	H
M8 x 1	-BS-M8	13.0(0.51)	8.7(0.34)	1.0(0.04)
M10 x 1	-BS-M10	16.0(0.63)	10.7(0.42)	1.5(0.06)
M12 x 1.5	-BS-M12	18.0(0.71)	12.7(0.50)	
M14 x 1.5	-BS-M14	22.0(0.87)	14.7(0.58)	
M16 x 1.5	-BS-M16	24.0(0.94)	16.7(0.66)	
M18 x 1.5	-BS-M18	26.0(1.02)	18.7(0.74)	
M20 x 1.5	-BS-M20	28.0(1.10)	20.7(0.81)	
M22 x 1.5	-BS-M22	30.0(1.18)	22.7(0.89)	2.0(0.08)
M24 x 1.5	-BS-M24	32.0(1.26)	24.7(0.97)	
M27 x 2	-BS-M27	36.0(1.42)	27.7(1.09)	
M30 x 2	-BS-M30	39.0(1.54)	30.7(1.21)	
M33 x 2	-BS-M33	42.0(1.65)	33.7(1.33)	2.5(0.10)
M36 x 2	-BS-M36	48.0(1.89)	37.0(1.46)	
M39 x 2	-BS-M39	51.0(2.00)	40.0(1.57)	
M42 x 2	-BS-M42	54.0(2.13)	43.2(1.70)	3.0(0.12)
M45 x 2	-BS-M45	57.0(2.24)	46.0(1.81)	
M48 x 2	-BS-M48	60.0(2.36)	49.0(1.93)	

► 订购信息 在基本订购号前面加上材料代码组成完整的订购号。

垫圈		代码
外圈	内圈	
不锈钢	FKM	SSF
碳钢	FKM	CSF
	丁腈橡胶	CSB

- ◆ 例:
 - 1、为 1/8 ISO 平行阳螺纹提供密封, 内圈为丁腈橡胶, 外圈为碳钢的 BS 垫圈的完整订购号是: CSB-BS-2。
 - 2、为 1/4 ISO 平行阳螺纹提供密封, 内圈为碳氟化合物, 外圈为不锈钢的 BSD 垫圈的完整型号是: SSF-BSD-4。
- ◆ BS、BSD 垫片仅用于 BS 接头。

► BR 垫片

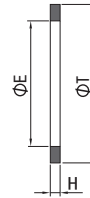

- ◆ BR 垫片为 ISO 平行阳螺纹提供密封。
- ◆ BR 垫片可用于 BR 接头。

ISO 平行 螺纹尺寸	基本 订购号	尺寸, in. (mm)		
		T	E	H
1/8	-BR-2	0.59(15.0)	0.39(9.9)	0.04(1.0)
1/4	-BR-4	0.75(19.1)	0.52(13.2)	0.06(1.5)
3/8	-BR-6	0.91(23.1)	0.66(16.8)	
1/2	-BR-8	1.06(26.9)	0.83(21.1)	
3/4	-BR-12	1.30(33.0)	1.05(26.7)	0.08(2.0)
1	-BR-16	1.58(40.1)	1.31(33.2)	

公制螺纹 尺寸	基本 订购号	尺寸, mm (in.)		
		T	E	H
M8 x 1	-BR-M8	13.2(0.52)	8.2(0.32)	1.5(0.06)
M10 x 1	-BR-M10	15.2(0.60)	10.2(0.40)	
M12 x 1.5	-BR-M12	18.2(0.72)	12.2(0.48)	2.0(0.08)
M14 x 1.5	-BR-M14	20.2(0.80)	14.2(0.56)	
M16 x 1.5	-BR-M16	22.2(0.87)	16.2(0.64)	
M18 x 1.5	-BR-M18	24.2(0.95)	18.2(0.72)	
M20 x 1.5	-BR-M20	26.2(1.03)	20.2(0.80)	
M22 x 1.5	-BR-M22	28.2(1.11)	22.2(0.87)	
M24 x 1.5	-BR-M24	30.2(1.19)	24.2(0.95)	2.5(0.10)
M27 x 2	-BR-M27	33.3(1.31)	27.2(1.07)	
M30 x 2	-BR-M30	37.3(1.47)	30.2(1.19)	
M33 x 2	-BR-M33	40.3(1.59)	33.2(1.31)	2.5(0.10)
M36 x 2	-BR-M36	43.3(1.70)	36.2(1.43)	
M39 x 2	-BR-M39	47.3(1.86)	39.2(1.54)	
M42 x 2	-BR-M42	50.3(1.98)	42.2(1.66)	
M45 x 2	-BR-M45	53.3(2.10)	45.2(1.78)	
M48 x 2	-BR-M48	56.3(2.22)	48.2(1.90)	

▶▶ **FG 垫片** FG 为压力表设备上 ISO 平行阳螺纹提供密封。

ISO 平行 螺纹尺寸	基本 订购号	尺寸, in. (mm)		
		T	E	H
1/4	-FG-4	0.42(10.7)	0.30(7.6)	0.07(1.8)
3/8	-FG-6	0.56(14.2)	0.34(8.6)	0.09(2.3)
1/2	-FG-8	0.70(17.8)	0.36(9.1)	0.10(2.5)

公制螺纹 尺寸	基本 订购号	尺寸, mm (in.)		
		T	E	H
M10 x 1	-FG-M10	8.3(0.33)	3.3(0.13)	1.5(0.06)
M12 x 1.5	-FG-M12	9.7(0.38)	5.4(0.21)	2.0(0.08)
M14 x 1.5	-FG-M14	11.7(0.46)	6.4(0.25)	
M16 x 1.5	-FG-M16	13.7(0.54)	8.4(0.33)	
M18 x 1.5	-FG-M18	15.7(0.62)	10.0(0.39)	
M20 x 1.5	-FG-M20	17.6(0.69)	11.4(0.45)	
M22 x 1.5	-FG-M22	19.6(0.77)	13.4(0.53)	
M24 x 1.5	-FG-M24	21.6(0.85)	14.8(0.58)	
M27 x 2	-FG-M27	24.0(0.95)	16.9(0.67)	2.5(0.10)
M30 x 2	-FG-M30	27.0(1.06)	19.5(0.77)	
M33 x 2	-FG-M33	30.0(1.18)	21.5(0.85)	
M36 x 2	-FG-M36	33.0(1.30)	23.5(0.93)	
M39 x 2	-FG-M39	36.0(1.42)	24.5(0.96)	
M42 x 2	-FG-M42	38.9(1.53)	29.5(1.16)	
M45 x 2	-FG-M45	41.9(1.64)	30.0(1.18)	
M48 x 2	-FG-M48	44.9(1.77)	32.5(1.28)	

▶▶ **RJ 垫片** RJ 垫片为日本压力表设备上 ISO 平行阳螺纹提供密封。

ISO 平行 螺纹尺寸	基本 订购号	尺寸, in. (mm)		
		T	E	H
1/4	-RJ-4	0.43(10.9)	0.22(5.6)	0.04(1.0)
3/8	-RJ-6	0.55(13.9)	0.22(5.6)	0.04(1.0)
1/2	-RJ-8	0.70(17.8)	0.22(5.6)	0.04(1.0)

▶▶ **订购信息** 在基本订购号前面加上材料代码组成完整的订购号。

材料	代码
铜	CU
316L 不锈钢	6L
硬化纸板	QB
PTFE	T

◆ 硬化纸板和PTFE不适用于BR垫片

◆ 例:

CU-BR-2, 6L-FG-6, QB-FG-M20, T-BT-8.

▶▶ O形圈



SAE/MS 直螺纹接头用 O 形圈。

SAE/MS螺纹尺寸	基本订购号	材料
5/16-24	VI9-902	90 度 碳氟化合物 FKM
3/8-24	VI9-903	
7/16-20	VI9-904	
1/2-20	VI9-905	
9/16-18	VI9-906	
3/4-16	VI9-908	
7/8-14	VI9-910	
1 1/16-12	VI9-912	
1 3/16-12	VI9-914	
1 5/16-12	VI9-916	
1 5/8-12	VI9-920	
1 7/8-12	VI9-924	

O 形圈密封管螺纹接头用 O 形圈。

NPT/ISO 螺纹尺寸	基本订购号	材料
1/8	BN7-013	70 度 NBR
1/4	BN7-113	
3/8	BN7-116	
1/2	BN7-118	

ISO 平行螺纹位置可调接头用 O 形圈。

ISO 平行螺纹尺寸	基本订购号	材料
1/8	VI9-502	90 度 碳氟化合物 FKM
1/4	VI9-111	
3/8	VI9-113	
1/2	VI9-508	
3/4	VI9-119	
1	VI9-217	

O 形圈密封直螺纹接头用 O 形圈。

SAE/MS螺纹尺寸	基本订购号	材料
5/16-24	BN7-011	70 度 NBR
3/8-24	BN7-012	
7/16-20	BN7-013	
1/2-20	BN7-112	
9/16-18	BN7-113	
3/4-16	BN7-116	
1 1/16-12	BN7-121	
1 5/16-12	BN7-125	

公制螺纹接头用 O 形圈。

公制螺纹尺寸	基本订购号	材料
M14×1.5	BN9-M14	90 度 NBR
M20×1.5	BN9-M20	

依乔流体技术(上海)有限公司

网址: www.e-joe.cn

电话: 021-6419-2603

EQ-JT-01-TC1-ZH-260402